

# FlexType™ R

## A STANDARD FLEXIBLE FEEDING SOLUTION

RNA's FlexType™ R flexible feeding system is a compact and proven package for handling complex and varied products, pre-configured and ready to use for fast integration. The solution combines robotics with intelligent vision software to deliver a complete system for flexible part feeding.

The FlexType™ R can be integrated into assembly lines, stand-alone machines, and as upgrades to existing equipment for any industry, with FDA-approved contact materials available on request for regulated sectors such as pharmaceuticals and food processing. High availability for random part feeding, constant performance with no jams and misfeeds make it a dependable long-term solution for manufacturers seeking both flexibility and productivity from a single feeding system.

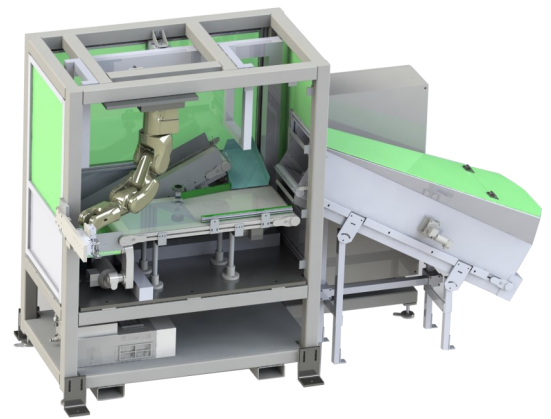

### Great flexibility

The FlexType™ R is the ideal feeder when flexibility is demanded in production. It allows for almost endless product line variations, feeding parts of any shape and geometry into any machine.

### High availability

High availability for random part feeding, constant performance with no jams and misfeeds.

### Quick and easy part changeover

Part changeover is rapid: selection on the user-friendly interface and a quick change-out of the end of arm tooling. Seamless, software-based product changeovers in minutes.

### Operator-friendly interface

The intuitive HMI simplifies operation, teaching, and calibration, reducing the risk of human error during setup and changeover.

### Easy to integrate

The FlexType™ R can be integrated into assembly lines, stand-alone machines, and as upgrades to existing equipment for any industry.

### Precise part detection

A reliable, accurate, and high-speed vision system ensures consistent part detection, even with challenging shapes, colours, and surface finishes.

### A variety of conveyor combinations

The FlexType™ R offers a complete range of conveyor combinations depending on cell layout needs.

### Broad industry applicability

Suitable for virtually any manufacturing sector — from automotive and electronics to medical devices and food processing — with FDA-approved contact materials available for regulated industries.

## Features

- Specifically designed for robot picking
- Integrated high performance FlexType™ R Vision systems
- Effective part separation
- User friendly, HMI controls interface
- Robot end of arm tool design, customised to part
- Various hopper size
- Various belt surfaces (flat / groove / anti-roll / other)

## Included in FlexType™ R

- RNA FlexType™ R Conveyor
- A suitable 6-axis robot depending on payload and reach
- Vision Inspection System
- Conveyor feeding system (depending on application)
- RNA Hopper (depending on application)
- Integrated control system with HMI
- Interlocked guarding

FlexType™ R Mini

FlexType™ R 200

FlexType™ R 300

SPECIFICATION			
Pick Window (w x l)	100 x 200 mm	200 x 300 mm	300 x 400 mm
Hopper	 <p>Various hopper sizes to suit your applications</p>		
Supply Power	240V a.c. 16 AMP		
OPTIONS			
Robot	Industrial 6-axis robot / cobot		
Vision	high resolution vision system		
Integrated LED lighting	backlight / toplight in various colours		
Various belt surfaces	flat / groove / anti-roll / other surface finishes and colours		
Contact materials	FDA approved on request (e.g. pharmaceuticals, food)		

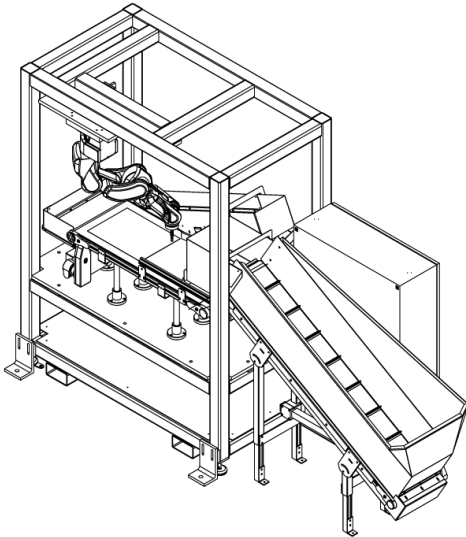

## FlexType™ R 300

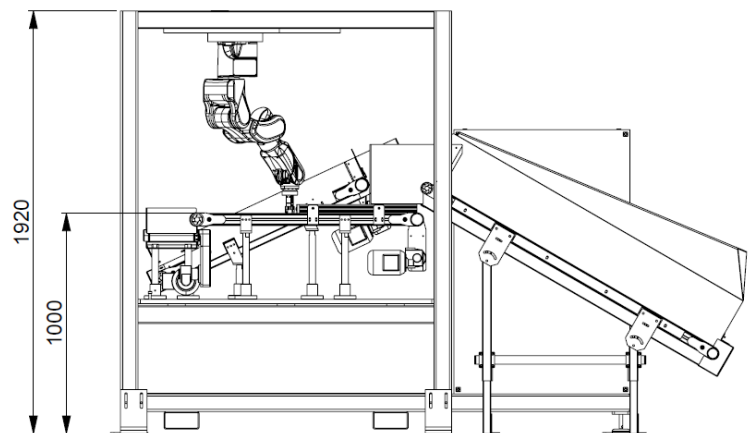
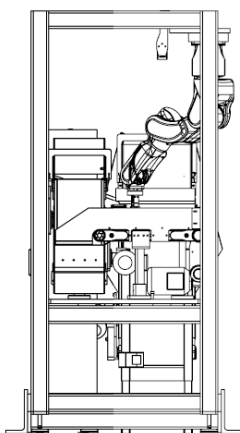
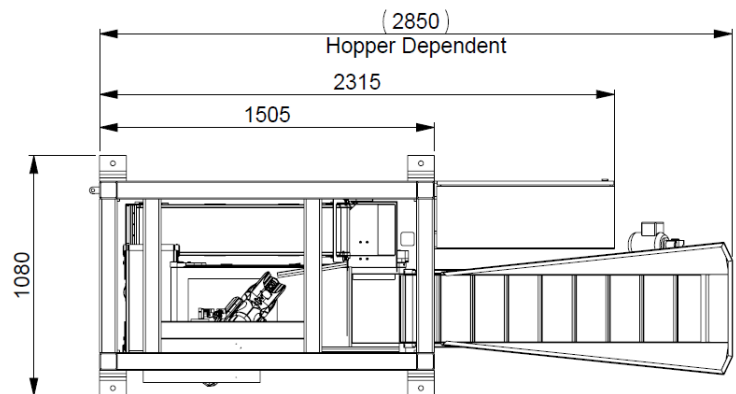

RNA Automation Ltd  
 Unit C Castle Bromwich Business Park, Tameside Drive, Birmingham B35 7AG, UK  
 Tel: +44 (0)121 749 2566 • Fax: +44 (0)121 749 6217  
 Email: sales@rnaautomation.com • Web: www.rnaautomation.com