

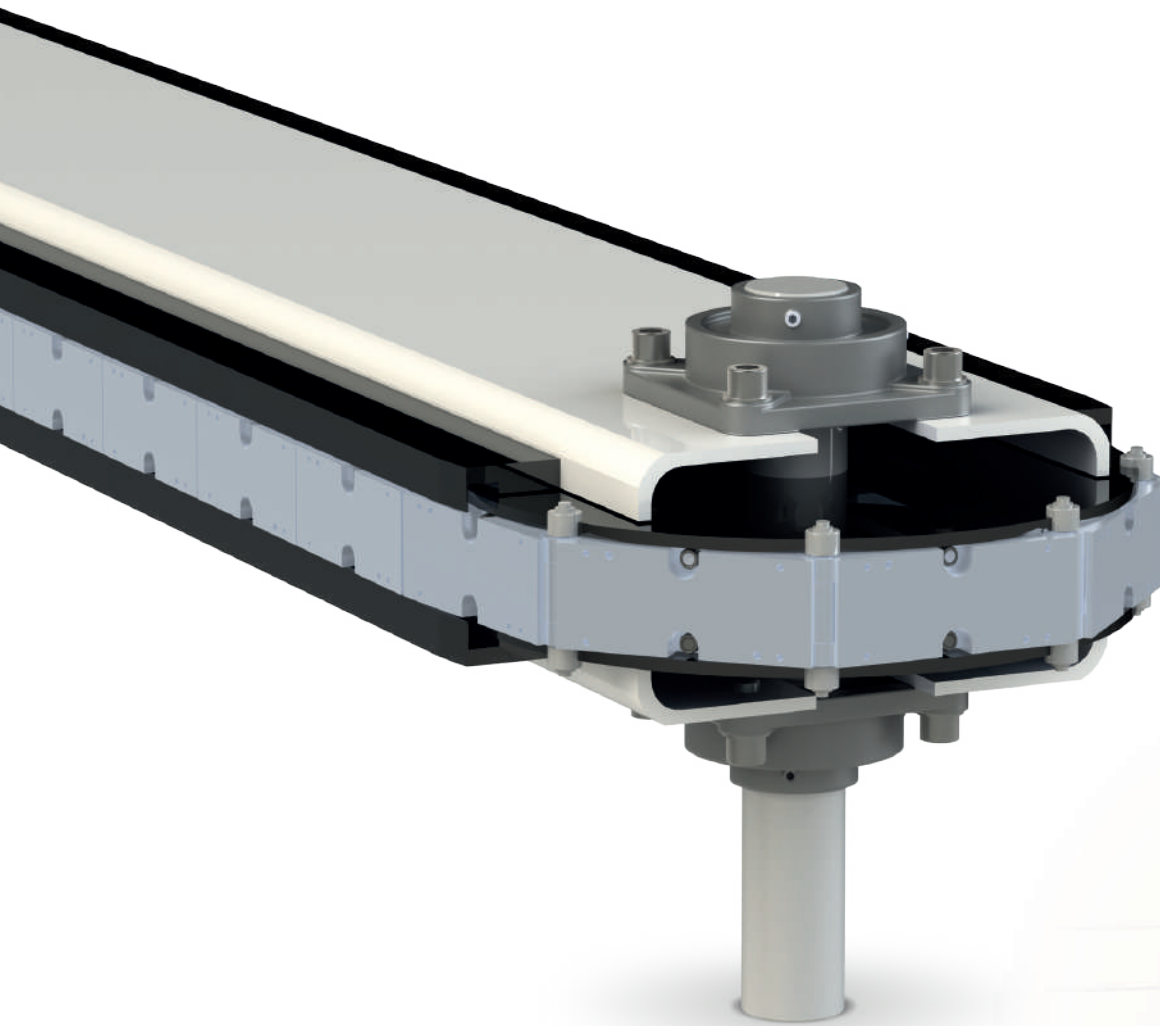

ITALPLANT

PRECISION TRANSFER SYSTEMS



CONVEYOR

PBC | PLC | PLC HA



Catalogue 2023

SUMMARY

Argument	Page
Introduction.....	3
Conveyors product range.....	4
Step 1: Choose your conveyor by accuracy	5
Step 2: Choose the mounting position	6
Step 3: Choose the motorization	7
Optional features	8
Examples of applications.....	12
Precision Belt Conveyors.....	15
PBC 60 mm	16
PBC 80 mm	17
PBC 100 mm	18
PBC 160 mm	19
PBC Square 60-80-100-160 mm.....	20
Precision Link Conveyors.....	21
PLC 3" (76,2 mm)	22
PLC 4" (101,6 mm)	23
PLC 4,5" (114,3 mm)	24
PLC 5.5" (139,7 mm)	25
PLC 6" (152,4 mm)	26
PLC 100 mm	27
PLC 125 mm	28
PLC 150 mm	29
PLC Square 3-4-4,5-5,5-6" - 100-125-150 mm.....	30
Precision Link Conveyors High Accuracy.....	31
PLC HA 1.5" (38,1 mm)	32
PLC HA 2" (50,8 mm).....	33
PLC HA 3" (76,2 mm).....	34
PLC HA 4" (101,6 mm).....	35
PLC 4" HA XL (101,6 mm)	36
PLC HA 4.5" (114,3 mm).....	37
PLC HA 5.5" (139,7 mm).....	38
PLC HA 6"(152,4 mm).....	39
PLC HA 8" (203,2 mm).....	40
PLC HA 12" (304,8 mm).....	41
PLC 100 mm	42
PLC 125 mm	43
PLC 150 mm	44
PLC 150 mm XL.....	46
PLC 250 mm	46
Data sheet.....	47

INTRODUCTION

Introduction

ITALPLANT conveyors are the state-of-the-art of conveyors for every kind of industry: mechanical, manufacturing, assembling, packaging, and every genre of applications: medical, cosmetic, electronic, and so on. ITALPLANT conveyors combine excellent accuracy, high speed, smooth movement, high load capacity, the versatility of positioning, custom length.

Driven by an ITALPLANT indexer with globoidal cam, able to guarantee a motion given by an incredible variety of motion laws (MS, MS20, MT, CYC, etc.), both standard than personal, the customer has the maximum degree of reliability.

The indexer is driven by a worm-gear reducer and three phase brake motor, or, if wished, by servo motor and driver provided by us. Type of motion can be, as a choice, continuous or periodic, with much longer dwell periods and custom length. Moreover, it is possible to couple the conveyor with ITALPLANT pick and place of PR or IP series, able to make loading/unloading cycles, synchronous with the conveyor.

To meet exactly all customer's needs, ITALPLANT can make a complete project that includes not only the complete system conveyor – placers with motorization, but also support base and tools to fit onto the links, or other components for load and unload. The possibility, in addition, to choose the length and the pitch of links permits to cover every customer wishes.



ITALPLANT Precision Belt Conveyor



ITALPLANT Precision Link Conveyor



ITALPLANT Precision Link Conveyor HA

The product you need

ITALPLANT has got the widest range of conveyors, with different accuracies for any kind of applications.

The first accuracy step is the patented **Precision Belt Conveyor** type, suitable for packaging, medium accuracy mounting and warehouse indexed storage. This kind of carrier is equipped with an aluminum beam, aluminum pallets fixed on a high precision timing belt, and auto-lubricating guides.

The patented shape of the pallets allow the this system to be used in carousel position, that is absolute news for a belt system.

This conveyor can be shipped mounted or only composed by the drive head, take-up head, and the other components ready to be mounted to the beam, that can also be provided by the customer (Get And Joint patent).

The second step is the standards **Precision Link Conveyor**, composed an aluminum beam and links connected together, equipped with roller followers that runs on steel guides. This kind of system is suitable for precision mounting in several fields, like mechanical, electrical, medical, hygiene and so on.

This PLC mounts hardened dual drive sprockets able to guarantee a transmission without backlash between the drive unit and chain links. On the opposite side, a special tensioning cam designed by our skill technical office can delete the chordal effect given by the polygonal effect of the chain during motion, maintaining a precise tension level of the chain in all its way.

Also, this conveyor can be shipped mounted or ready to be mounted to the beam, that can also be provided by the customer (Get And Joint patent).

The most accurate conveyor is the **Precision Link Conveyor High Accuracy**, the best that you can obtain in the field of linear indexing systems. This carrier is equipped as the standard PLC with aluminum links connected together (it's also possible steel or other materials on customer's demand), but with a structural steel beam. This beam, that is machined with high accuracy procedures, allow to this system to reach a very high value of repeatability accuracy, suitable for fields like the microelectronics, medical, precise mounting and the automotive, thanks to the **Heavy Duty PLC HA type**.

CONVEYORS PRODUCT RANGE

PBC

(pag. 15)

PBC 60 mm
PBC 80 mm
PBC 100 mm
PBC 160 mm

PLC

(pag. 21)

PLC 3"
PLC 4"
PLC 4.5"
PLC 5.5"
PLC 6"
PLC 100 mm
PLC 125 mm
PLC 150 mm

PLC HA

(pag. 31)

PLC 1.5"
PLC 2"
PLC 3"
PLC 4"
PLC 4" XL
PLC 4.5"
PLC 5.5"
PLC 6"
PLC 8"
PLC 12"
PLC 100 mm
PLC 125 mm
PLC 150 mm
PLC 150 mm XL
PLC 250 mm

STEP 1: CHOOSE YOUR CONVEYOR BY ACCURACY

Each link of ITALPLANT conveyor shows an accuracy value that can be measured along the three directions of length, width, height (X, Y, Z). All measurements will be taken at the fixture locating dowel pin and inspected one link in from the take-up end.

The "Y" (side to side accuracy) and "Z" (vertical accuracy) tolerance value will remain the same at any given station along the entire length of the conveyor.

The "X" direction tolerance value will be greatest at the link farthest from the drive sprocket and will improve with closer proximity to the sprocket (index accuracy).

ITALPLANT cannot put an exact value on this accuracy improvement and will only guarantee the accuracy listed below for the entire length of the conveyor.

These accuracy values relate to any given station NOT as one station relates to another.

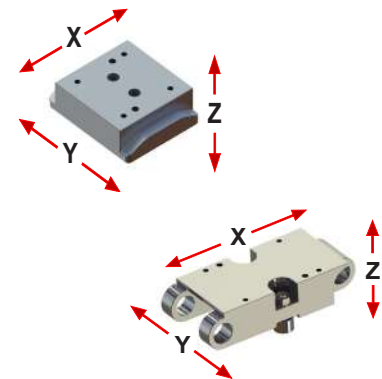

	Link TYPE and SIZE	Tolerance X within MINIMUM LENGHT (indicated)	Tolerance X beyond MINIMUM LENGHT EVERY 500 mm	Tolerances Y and Z for each link
PBC	PBC 60 mm	± 0,23 mm (540 mm)	± 0,08 mm	± 0,25 mm
	PBC 80 mm	± 0,20 mm (560 mm)	± 0,06 mm	± 0,15 mm
	PBC 100 mm	± 0,20 mm (600 mm)	± 0,06 mm	± 0,15 mm
	PBC 160 mm	± 0,25 mm (960 mm)	± 0,06 mm	± 0,15 mm
PLC	PLC 3" (76,2 mm)	± 0,127 mm (609.6mm)	± 0,042 mm	± 0,127 mm
	PLC 4" (101,6 mm)	± 0,119 mm (711,2 mm)	± 0,021 mm	± 0,127 mm
	PLC 4,5" (114,3 mm)	± 0,118 mm (685,8 mm)	± 0,021 mm	± 0,127 mm
	PLC 5,5" (139,7 mm)	± 0,118 mm (698,5 mm)	± 0,021 mm	± 0,127 mm
	PLC 6" (152,4 mm)	± 0,115 mm (609,6 mm)	± 0,021 mm	± 0,127 mm
	PLC 100 mm	± 0,119 mm (700 mm)	± 0,021 mm	± 0,127 mm
	PLC 125 mm	± 0,126 mm (875 mm)	± 0,021 mm	± 0,127 mm
	PLC 150 mm	± 0,127 mm (900 mm)	± 0,021 mm	± 0,127 mm
PLC High Accuracy	PLC HA 1,5" (38,1 mm)	± 0,039 mm (228,6 mm)	± 0,008 mm	± 0,050 mm
	PLC HA 2" (50,8 mm)	± 0,040 mm (304,8 mm)	± 0,008 mm	± 0,050 mm
	PLC HA 3" (76,2 mm)	± 0,041 mm (381 mm)	± 0,008 mm	± 0,050 mm
	PLC HA 4" (101,6 mm)	± 0,035 mm (508 mm)	± 0,007 mm	± 0,040 mm
	PLC HA 4" (101,6 mm) - XL	± 0,040 mm (609.6 mm)	± 0,007 mm	± 0,040 mm
	PLC HA 4,5" (114,3 mm)	± 0,036 mm (571.5 mm)	± 0,007 mm	± 0,040 mm
	PLC HA 5,5" (139.7 mm)	± 0,035 mm (558.8 mm)	± 0,007 mm	± 0,040 mm
	PLC HA 6" (152.4 mm)	± 0,036 mm (609.6 mm)	± 0,007 mm	± 0,040 mm
	PLC HA 8" (203.2 mm)	± 0,043 mm (812.8 mm)	± 0,007 mm	± 0,040 mm
	PLC HA 12" (304.8 mm)	± 0,049 mm (1219.2 mm)	± 0,007 mm	± 0,040 mm
	PLC HA 100 mm	± 0,035mm (500 mm)	± 0,007 mm	± 0,040 mm
	PLC HA 125 mm	± 0,035 mm (500 mm)	± 0,007 mm	± 0,040 mm
	PLC HA 150 mm	± 0,036 mm (600 mm)	± 0,007 mm	± 0,040 mm
	PLC HA 150 mm - XL	± 0,042 mm (750 mm)	± 0,007 mm	± 0,040 mm
PLC HA 250 mm	± 0,045 mm (1000 mm)	± 0,007 mm	± 0,040 mm	

STEP 2: CHOOSE THE MOUNTING POSITION

CAROUSEL mounting position

Carousel conveyors show the links on right and left side. For this peculiarity that gives the possibility to work on both sides, it is possible to use for the stations the total length of the conveyor. This type of conveyor does not permit, anyway, to load directly on links but only by fixtures mounted laterally on itself to carry a load that rollers could bear: indispensable then to calculate every time the overturning torque on links and fixtures that are generally out of the centre.



OVER-UNDER mounting position

Over-Under conveyors are imagined to work usually on the upper side, on the open view, but in comparison to the preceding ones are more suitable to be carried by a pick and place or robots, and they are able to bear loads or external forces directly on the links. Otherwise, with the same number of fixtures, you have to provide a double length than Carousel.

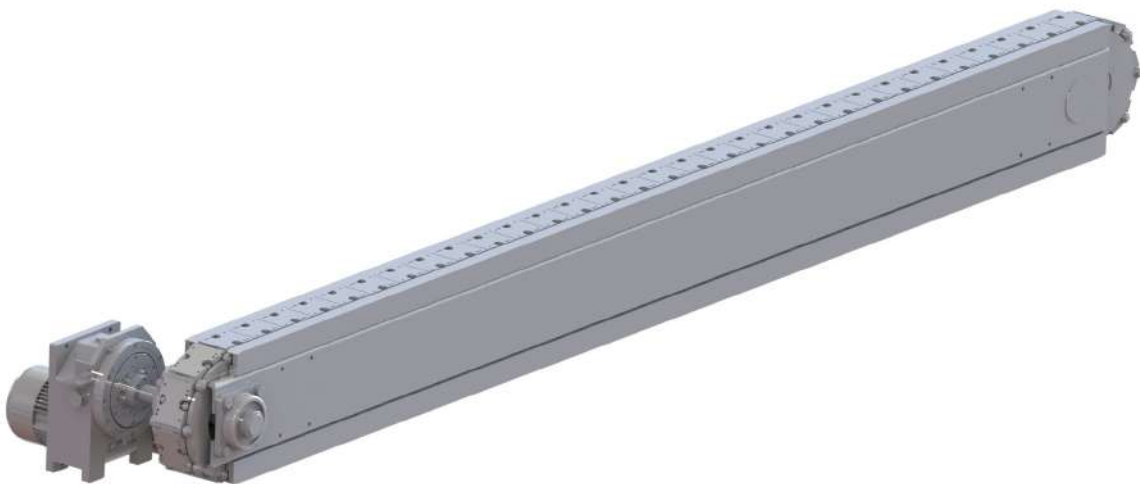

STEP 3: CHOOSE THE MOTORIZATION

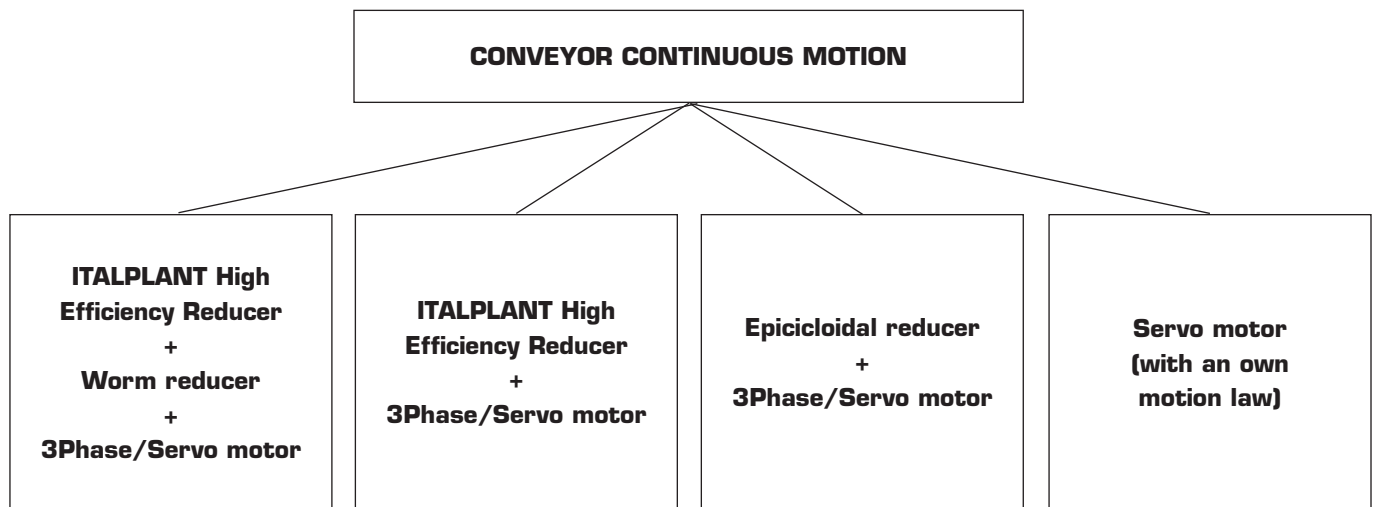
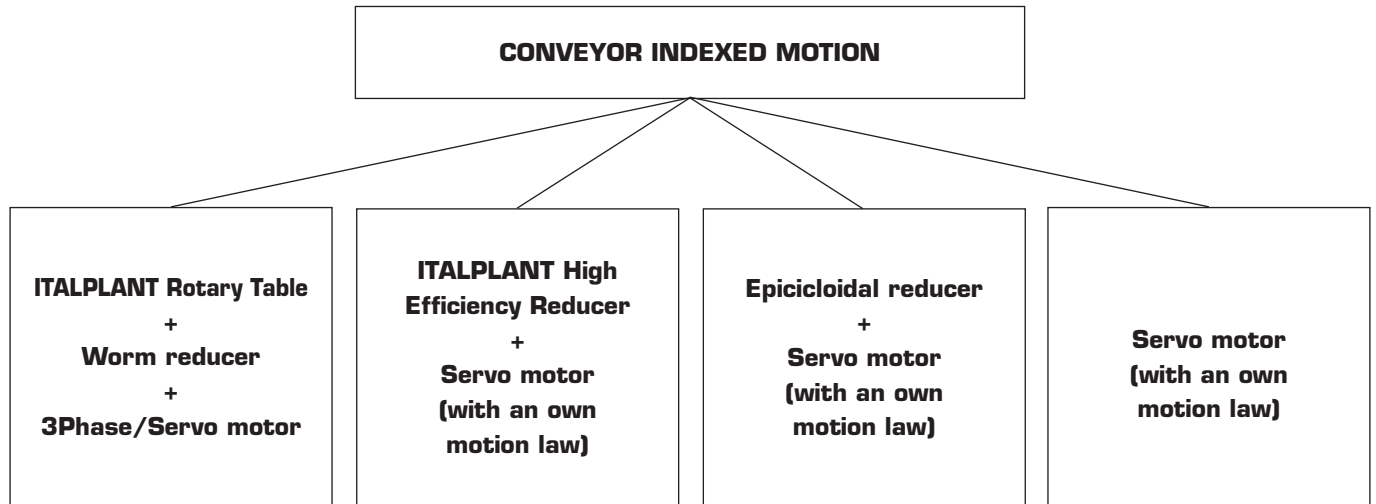

ITALPLANT Globoidal Rotary Table



ITALPLANT High Efficiency Reducer



Epicicloidial reducer

OPTIONAL FEATURES

PENDULAR MOUNTING

The mounting of the motorization to the conveyor is an operation that needs to follow the particular specification, to maintain the isostatic position of the input shaft. Without this controls, it could be possible to damage the conveyor during its life. For this reason, Italplant has developed the Pendular Mounting option.

The suspended anchorage of the rotary table allows having the possibility to receive the conveyor with motorization, saving assembly time for the customer.

This solution is available in both Carousel and Over-Under versions.

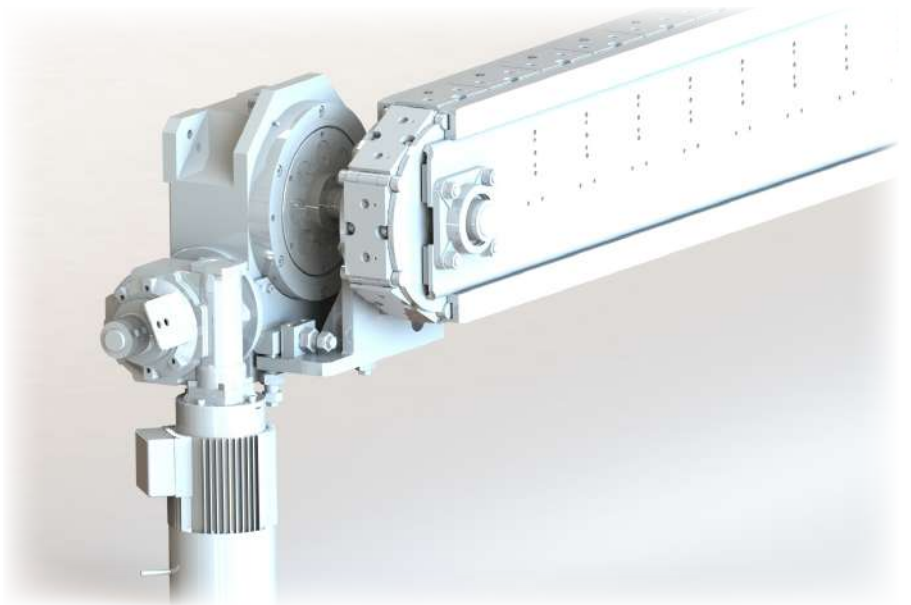

SUPPORT LEGS

To allow the customer to mount easily the conveyor without stress its structure, it's possible to get ITALPLANT support legs.

These legs have got a special X-Y-Z axis calibration, for a fine position of them on the support structure of the machine. These supports can be provided in aluminum or steel. In the case of steel, it's possible to ask for paint in custom RAL color, browning or phosphating. The legs can be also provided in stainless steel.

BASE FRAME

Italplant provides a wide range of base frame for the support of the conveyors. These options have got several advantages:

- To mount all the support legs and the motorization without hyperstatic situation
- Major rigidity for the shipping of the conveyor
- To save money for the mounting and adapting of the conveyor to its support structure

Every base frame can be provided for Carousel or Over-Under mounting positions.

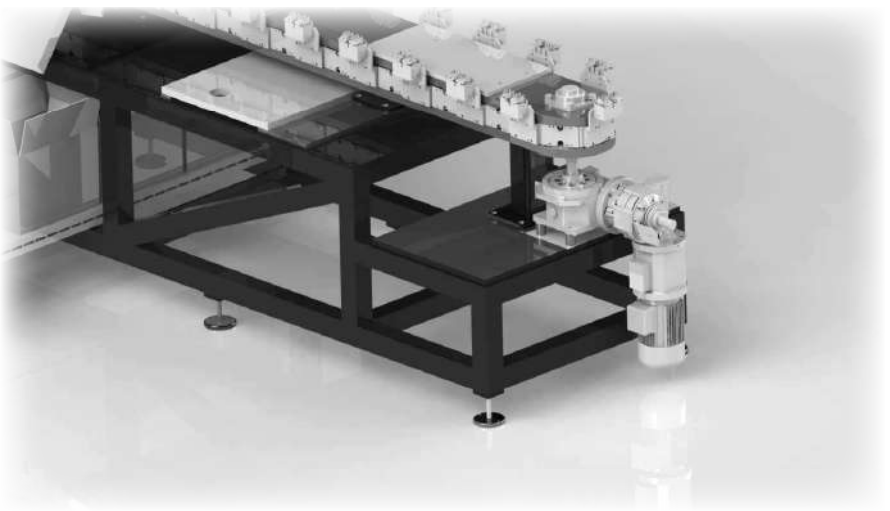

OPTIONAL FEATURES



TWIN CONVEYORS

For all the applications where it's necessary to have two chains with independent motion, ITALPLANT can provide the twin conveyors version.

In this case, the beam is two, identically, positioned in a unique structure (with their distance that can be regulated, if requested). Each beam supports a chain that has got an independent motion from the other one: this solution is suitable in case of tandem mounting, usually motorized by a servo motor.

A unique pass-through shaft can be provided on request.

DOUBLE BEAM CONVEYOR

In case of the necessity to have two synchronized chain, ITALPLANT can provide the double beam conveyor version.

This solution is suitable for all the applications that require a widest lateral dimension for the support of the pieces. In fact, in this solution, the beam is one, and the two chains are moved by a unique shaft, with the same motion.

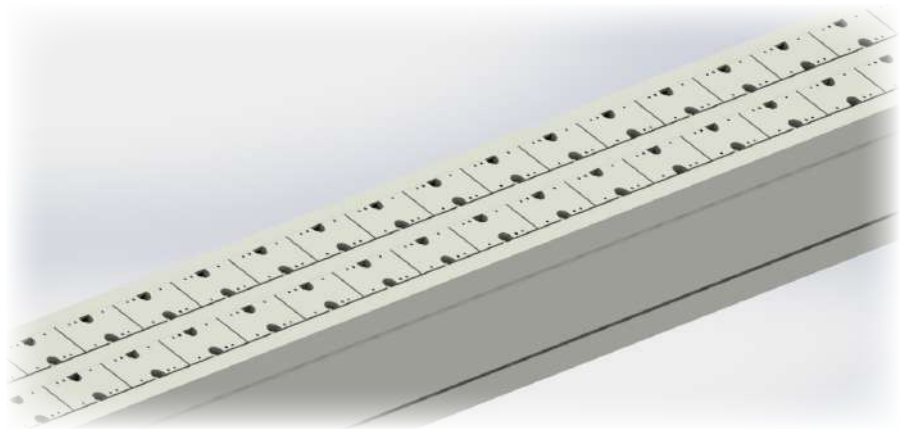

SQUARED CONFIGURATION (PATENTED)

There is a particular shape of ITALPLANT transfer system studied exactly for the application where a large pass-through hole is required, for big dimension passages or - in case of Carousel mounting position - to allow to the customer to position additional mounting stations inside to the quadrilateral shape.

To allow it, ITALPLANT has patented a square shape of Precision Belt Conveyors (Page 20) and Precision Link Conveyors (Page 30). This version has got the same links of the traditional conveyor versions.



OPTIONAL FEATURES



CUSTOM FIXING HOLES AND OPENINGS

All the pallets fixing holes can be provided at custom specifications.

In addition to that, for the Precision Link Conveyors High Accuracy, thanks to the fact that the beam is composed by structural steel, it's possible to ask for special fixing holes, centering holes and openings with fully customizable size and position. Our Technical Dept. will follow customer's specifications in the co-engineering phase, up to confirmation of the custom installation drawing.

TIMING DEVICE (PATENTED)

This patented system has been developed by ITALPLANT for all the applications where it's necessary to change the support of the fixtures on each conveyor link, for a production batch change.

Usually, this operation requires much time and technicians to work on it. With this automating phasing system, without any disassembly, it's possible in less than one minute to change the production batch.

It's only necessary (for example for three types of pieces), to mount the fixtures in this way: A-B-C-A-B-C-A-B. During the rephasing, automatically the conveyor will change the work position from A to B or C.

An important note is that this is a mechanical system, that eliminates any errors, which otherwise can be caused by electronically controlled systems.

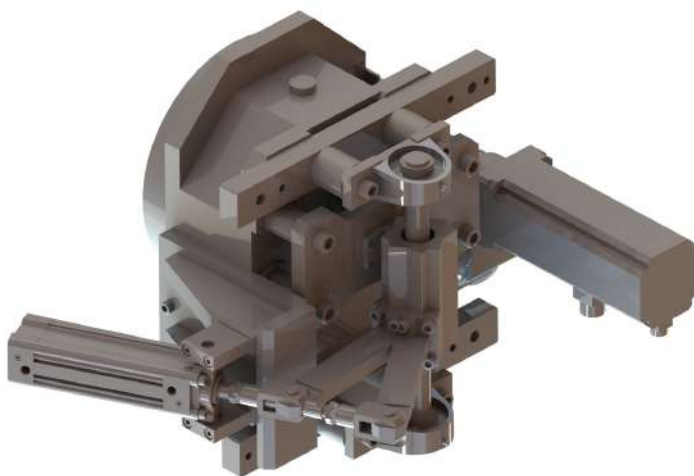

HHA ACCURACY

The accuracy chart (page 5) allows the customers to choose between a wide range of accuracy in terms of repeatability in X-Y-Z directions. In case of an extremely high accuracy required also in the planarity, ITALPLANT can provide special PLC with HHA accuracy links, that has got better repeatability in X-Y-Z directions, plus certified planarity accuracy value (up to ± 0.005 mm).

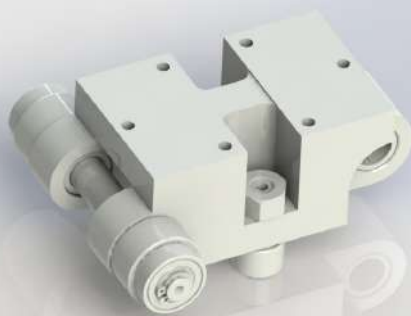

OPTIONAL FEATURES

SOTL+ATT (PATENTED)

This patented systems, included in all the ITALPLANT rotary table, allows the system motorization+conveyors to protect himself in case of external jamming, on the links.

The protection it's possible thanks to friction positioned internally to the rotary table mechanism, that in case of jamming - after the reach of a max. allowable torque - that it's possible to set manually - disengages the internal mechanism, giving an electrical emergency signal and protect the rotary table.

Thanks to this feature the Warranty of the rotary tables becomes 5 Years.

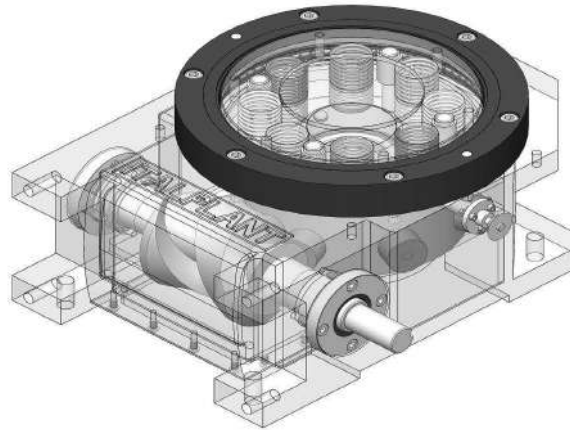

HIGH TEMPERATURE/ SPECIAL COATING

In case of applications with a temperature higher than 100°C (373 K), instead of aluminum - that is used to give better performance thanks to its low specific density - the links can be provided in cast iron, due to its low thermal expansion.

In case of white room applications or specific requirements (food, explosive, hygiene..) the pallets can be provided also in stainless steel, as for the PLC HA beam, that can be also painted in custom RAL color, browned or phosphated.

GET AND JOINT SYSTEM (PATENTED)

This patented system allows the customer to receive the main conveyor components into a small wooden box and mounts them on the aluminum beam of standard model type, that easily can be found on the market.

In this way - especially for long conveyors - it's possible to save money and time, simply following the instruction provided by ITALPLANT.

This option can be provided for the Precision Belt Conveyors (Page 13) and Precision Link Conveyors (Page 19), and in this catalog, its highlighted by the Get And Joint logo on the right.

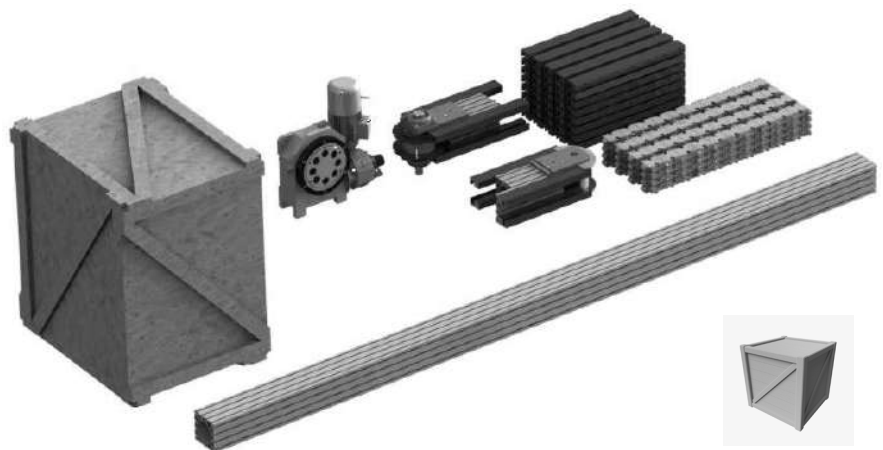

GET AND JOINT
version available

EXAMPLES OF APPLICATIONS



PBC 80 x 1000 mm - Drawer guides assembly

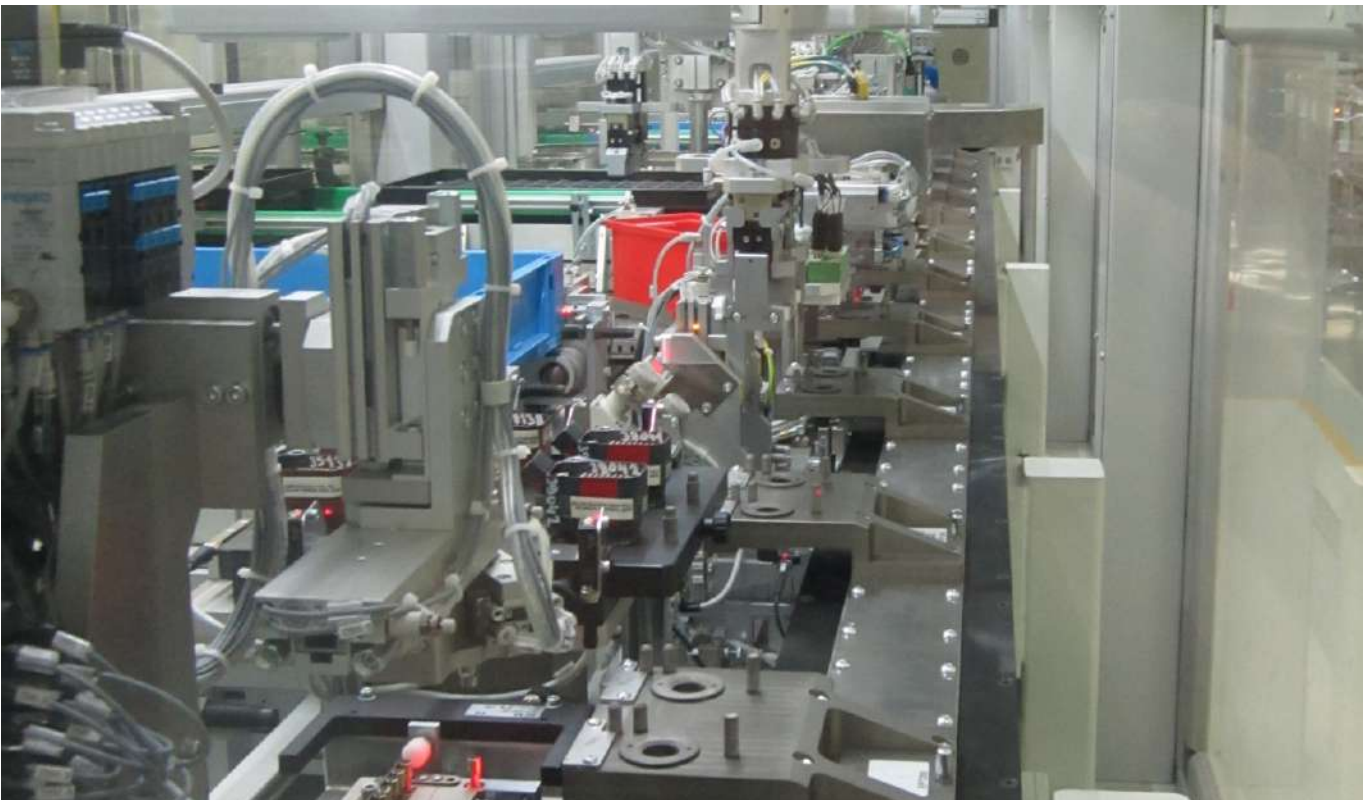

PLC HA 5.5 x 196" - Pencil ignition coils assembly

EXAMPLES OF APPLICATIONS

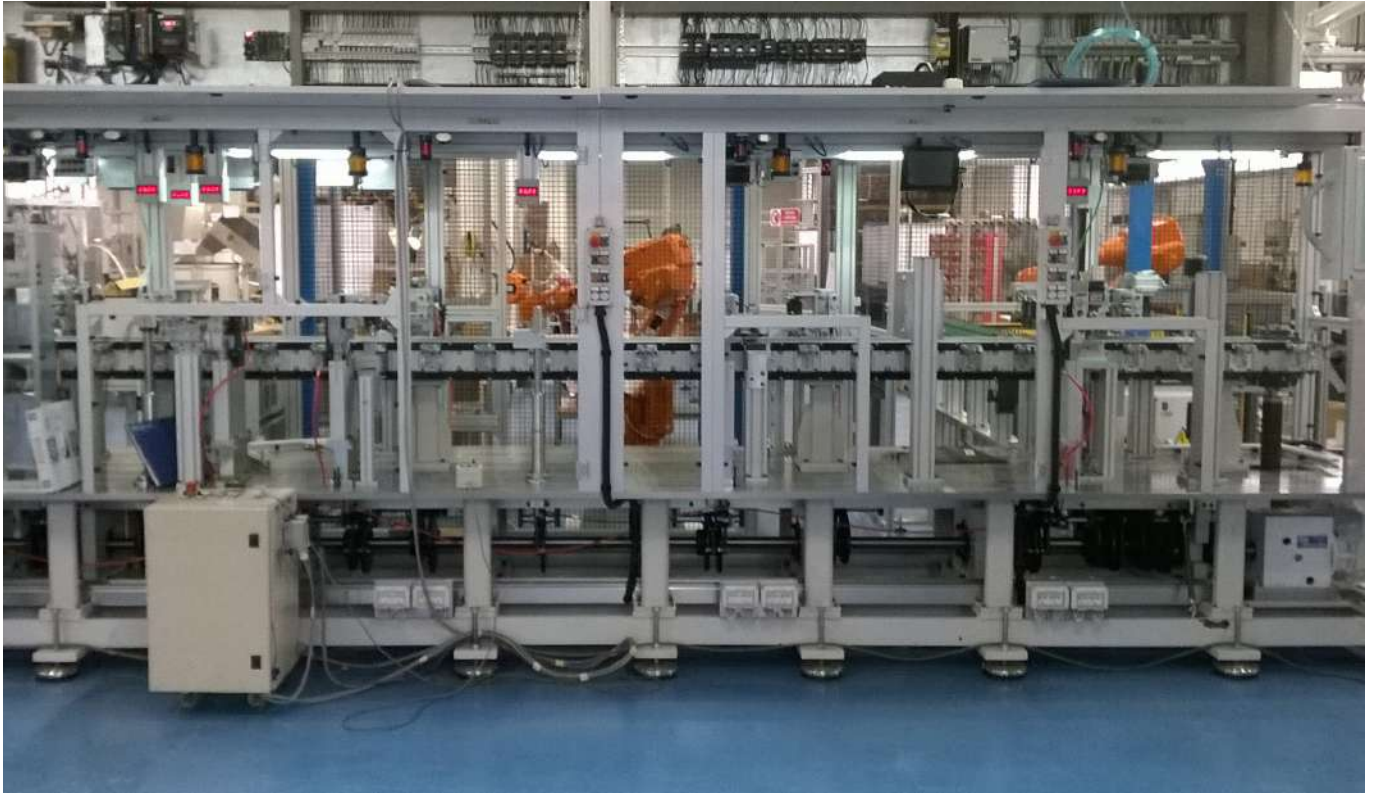

PLC HA 4" x 200" - Tools assembly



PLC HA 5.5 x 77" - Furniture components assembly

PRECISION BELT CONVEYORS

The ITALPLANT patented Precision Belt Conveyors PBC represents an absolute innovation in the sector of pallets transport.

It's almost an all-aluminum structure, that combines two basic concepts for the customer: modular structure according to the customer's needs and hugely lower costs, compared to other transport belt systems.

This has been possible by a combination of design essential and rigid mechanical linkages: the result is a conveyor suitable for many applications at a higher level than its competitor's belt, and yet much cheaper.

The motorizations applicable may provide an intermittent motion - Italplant rotary tables or HER/servo motor with an own motion law - or continuous - HER/servo motor - (page 7).

Features:

- ITALPLANT patented system
- Metric version
- Lightweight structure with an aluminum profile
- Auto-lubricating guides
- Get And Joint version available (see page 11)
- The squared version available (see page 12)
- Over-Under / Carousel mounting options
- Length and size of the aluminum pallets, other specifications
- General specifications: height, total length, even or odd pallets, disposition



Available link sizes

60 mm - 80 mm - 100 mm - 160 mm

PBC 60 mm

Pallet length: 60 mm

Centre distance: from 540 to 7380 mm

Load capacity:

- Every two pallets: 20 kg
- Every single pallet: 10 kg

Overhung load capacity: 30 Nm

Length deviation: + 0,18 mm/pallet

Accuracy:

- **X axis** $\pm 0,25$ mm up to 540 mm + $\pm 0,08$ mm every 500 mm
- **Y axis** $\pm 0,25$ mm
- **Z axis** $\pm 0,25$ mm

Pallets tilts displacements:

- **X axis** $\pm 0,18$ mm
- **Y axis** $\pm 0,18$ mm
- **Z axis** $\pm 0,18$ mm

Pallet overview

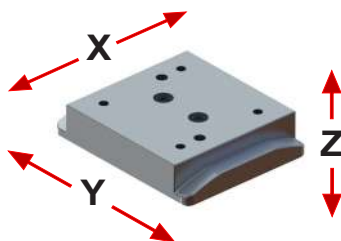

Additional features

- 8 pockets sprockets
- ITALPLANT patented system
- Aluminum profile beam
- Squared version available (see page 20)
- Get And Joint version available
- Over-Under / Carousel mounting options

Optionals on request

- Globoidal Indexer as motorization
- Special Input shaft
- Customized pallets fixing holes
- Additional T-slots nuts
- Pendular mounting of the motorization
- Legs with X-Y-Z regulation
- Base frame

VIEW FROM "A"

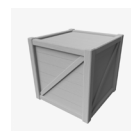
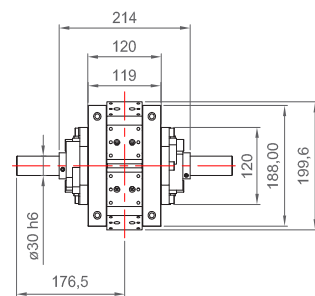
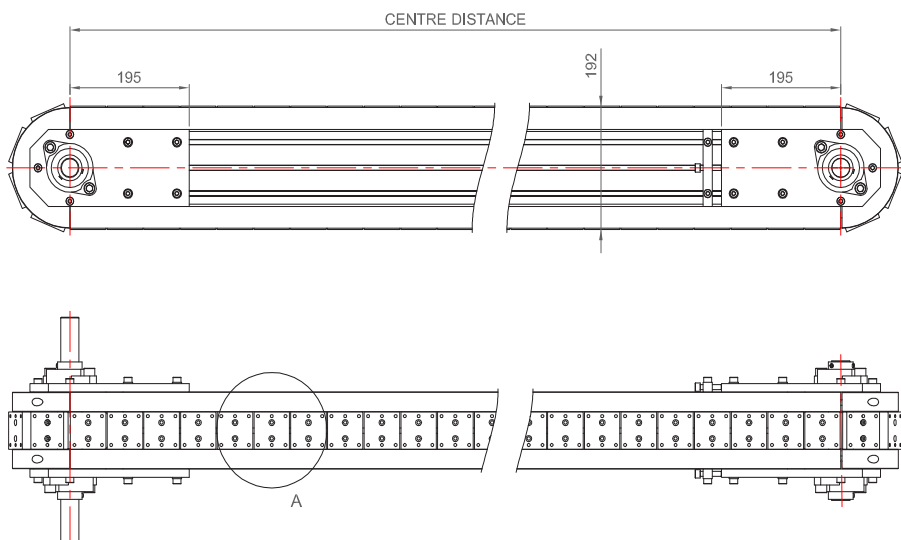
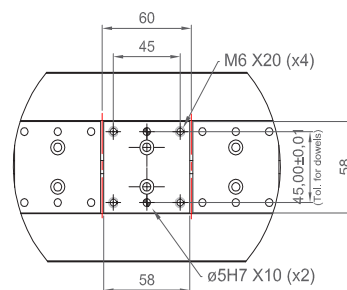

GET AND JOINT
version available

Available strokes	Center distance dimension	Denomination
15 - 30 - 60 - 120 - 180 - 240 - 300 - 360 - 420 - 480 mm OTHER STROKES AVAILABLE WITH SERVOMOTORS	540 mm to 7380 mm	PBC 60

PBC 80 mm

Pallet length: 80 mm

Centre distance: from 560 to 7360 mm

Load capacity:

- Every dual pallets: 30 kg
- Every single pallet: 15 kg

Overhung load capacity: 50 Nm

Length deviation: + 0,05 mm/pallet

Accuracy:

- **X axis** ± 0,20 mm up to 560 mm +
± 0,06 mm every 500 mm
- **Y axis** ± 0,15 mm
- **Z axis** ± 0,15 mm

Pallets tilts displacements:

- **X axis** ± 0,18 mm
- **Y axis** ± 0,18 mm
- **Z axis** ± 0,18 mm

Pallet overview

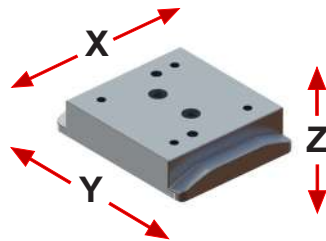

Additional features

- 6 pockets sprockets
- ITALPLANT patented system
- Aluminum profile beam
- Squared version available (see page 20)
- Get And Joint version available
- Over-Under / Carousel mounting options

Optionals on request

- Globoidal Indexer as motorization
- Special Input shaft
- Customized pallets fixing holes
- Additional T-slots nuts
- Pendular mounting of the motorization
- Legs with X-Y-Z regulation
- Base frame

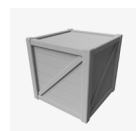
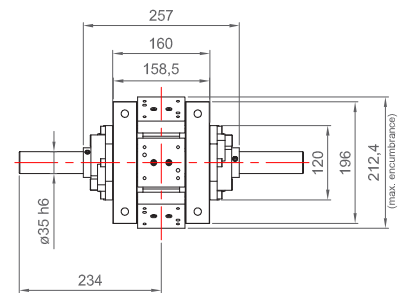
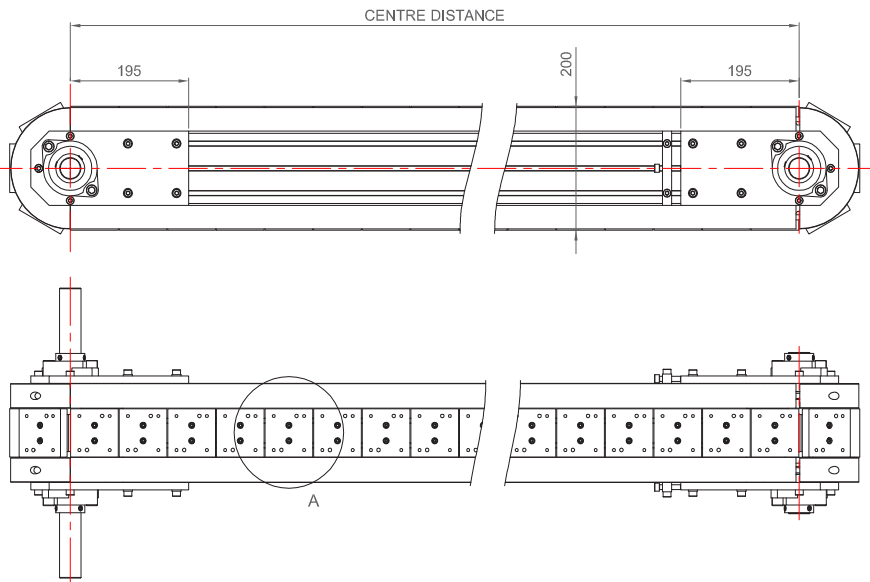
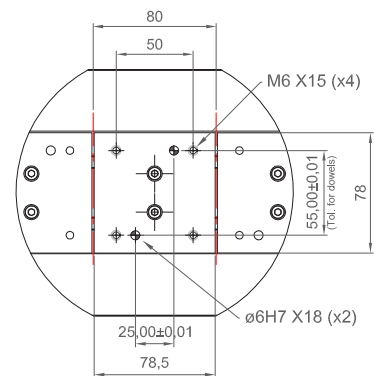

GET AND JOINT
version available

Available strokes	Center distance dimension	Denomination
20 - 40 - 80 - 160 - 240 - 320 - 400 - 480 mm FLEXIBLE STROKES WITH SERVO MOTOR	560 mm to 7360 mm	PBC 80

PBC 100 mm

Pallet length: 100 mm

Centre distance: from 600 to 7300 mm

Load capacity:

- Every two pallets: 20 kg
- Every single pallet: 40 kg

Overhung load capacity: 60 Nm

Length deviation: + 0,18 mm/pallet

Accuracy:

- **X axis** $\pm 0,20$ mm up to 600mm + $\pm 0,06$ mm every 500 mm
- **Y axis** $\pm 0,15$ mm
- **Z axis** $\pm 0,15$ mm

Pallets tilts displacements:

- **X axis** $\pm 0,18$ mm
- **Y axis** $\pm 0,18$ mm
- **Z axis** $\pm 0,18$ mm

Pallet overview

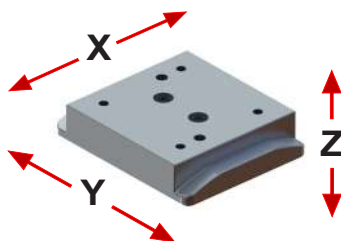

Additional features

- 6 pockets sprockets
- ITALPLANT patented system
- Aluminum profile beam
- Squared version available (see page n.20)
- Get And Joint version available
- Over-Under / Carousel mounting options

Optionals on request

- Globoidal Indexer as motorization
- Special Input shaft
- Customized pallets fixing holes
- Additional T-slots nuts
- Pendular mounting of the motorization
- Legs with X-Y-Z regulation
- Base frame

VIEW FROM "A"

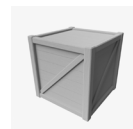
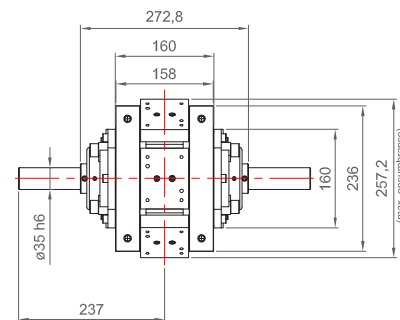
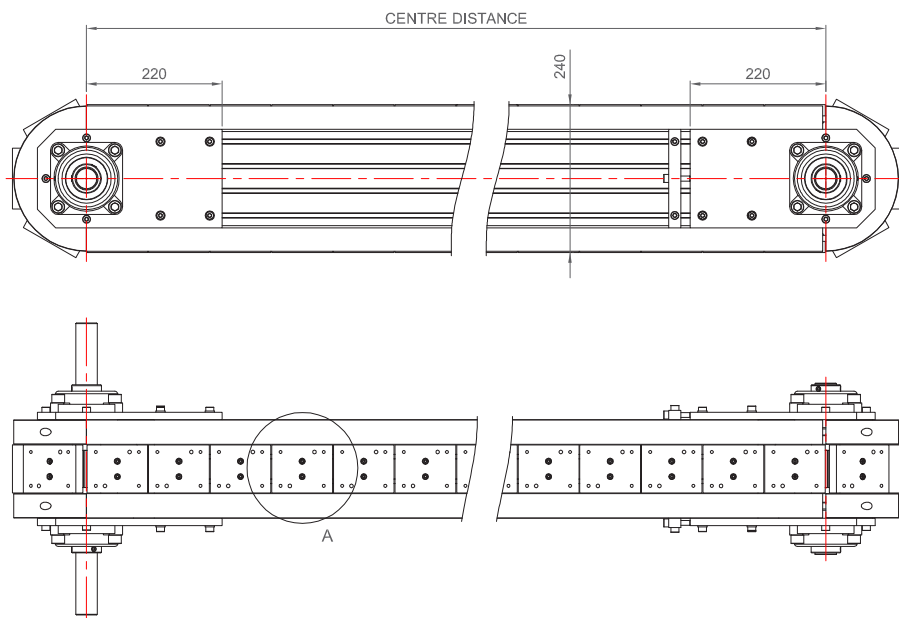
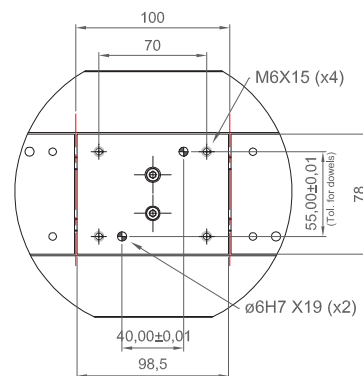

GET AND JOINT
version available

Available strokes	Center distance dimension	Denomination
25 - 50 - 100 - 200 - 300 - 400 - 500 - 600 mm FLEXIBLE STROKES WITH SERVO MOTOR	600 mm to 7300 mm	PBC 100

PBC 160 mm

Pallet length: 160 mm
Centre distance: from 960 to 7040 mm

Load capacity:

- Every dual pallets: 60 kg
- Every single pallet: 30 kg

Overhung load capacity: 80 Nm

Length deviation: + 0,05 mm/pallet

Accuracy:

- **X axis** ± 0,25 mm up to 960 mm +
± 0,06 mm every 500 mm
- **Y axis** ± 0,15 mm
- **Z axis** ± 0,15 mm

Pallets tilts displacements:

- **X axis** ± 0,18 mm
- **Y axis** ± 0,18 mm
- **Z axis** ± 0,18 mm

Pallet overview

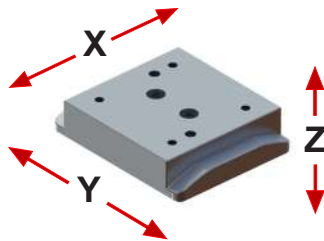

Additional features

- 6 pockets sprockets
- ITALPLANT patented system
- Aluminum profile beam
- Squared version available (see page n.20)
- Get And Joint version available
- Over-Under / Carousel mounting options

Optionals on request

- Globoidal Indexer as motorization
- Special Input shaft
- Customized pallets fixing holes
- Additional T-slots nuts
- Pendular mounting of the motorization
- Legs with X-Y-Z regulation
- Base frame

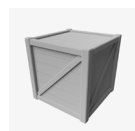
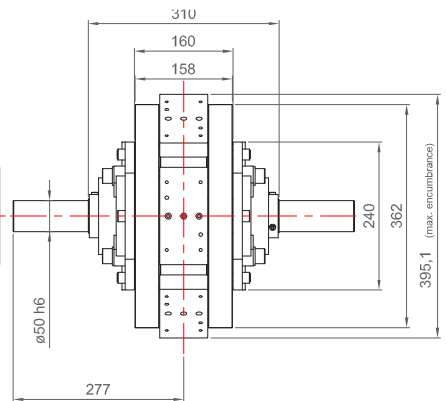
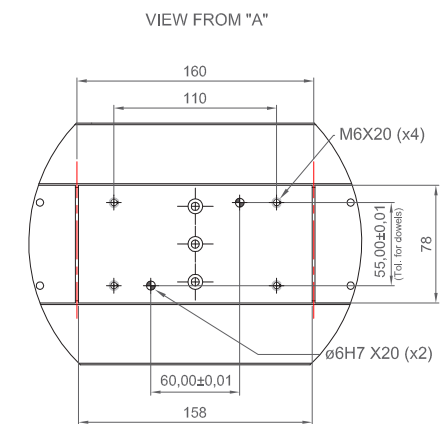
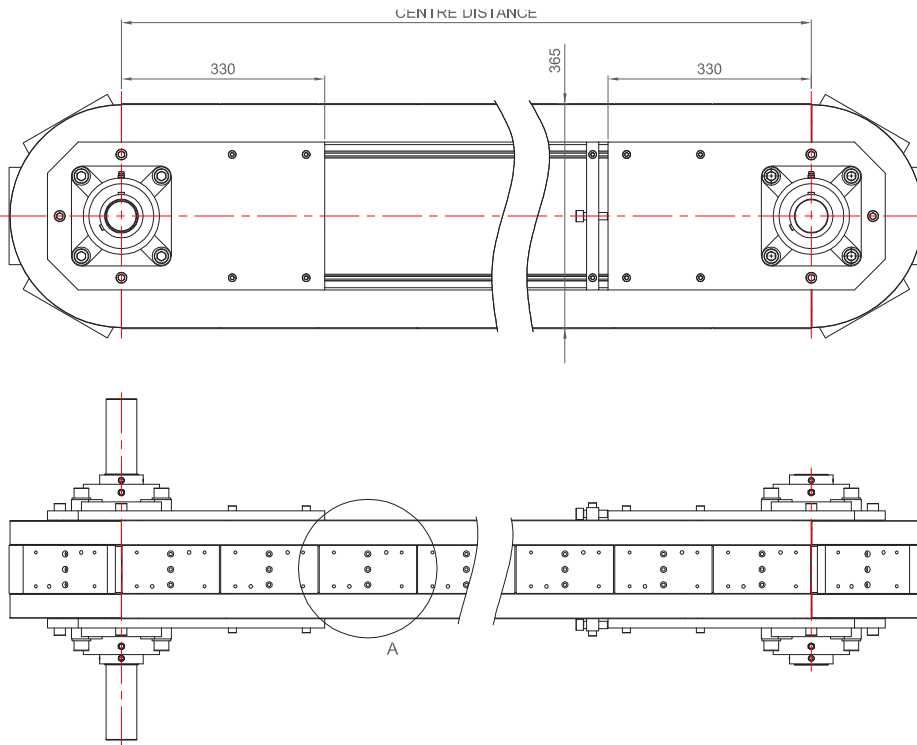

GET AND JOINT
version available

Available strokes	Center distance dimension	Denomination
40 - 80 - 160 - 320 - 480 - 640 - 800 - 960 mm FLEXIBLE STROKES WITH SERVO MOTORS	960 mm to 7040 mm	PBC 160

PBC SQUARE 60 - 80 - 100 - 160 mm

Pallet length: 60-80-100-160 mm

Centre distance: (various values)

Load capacity: (pages 16-19)

Overhung load capacity: (pages 16-19)

Additional features

- ITALPLANT patented system
- Aluminum profile beam
- Autolubricating guides
- Get And Joint version available
- Over-Under / Carousel mounting options

Optionals on request

- Globoidal Indexer as motorization
- Special Input shaft
- Customized pallets fixing holes
- Additional T-slots nut
- Pendular mounting of the motorization
- Legs with X-Y-Z regulation
- Base frame

PBC SQUARE overview

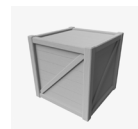
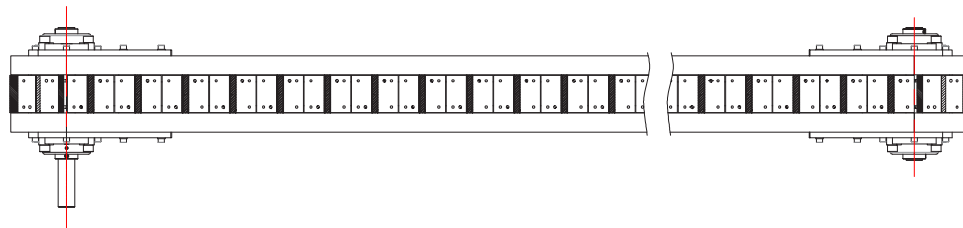
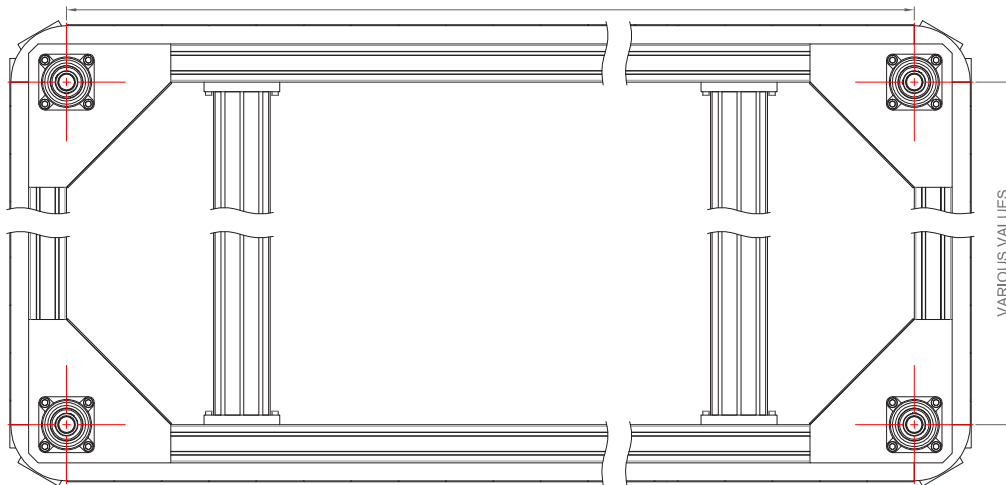

GET AND JOINT
version available

Available strokes	Center distance dimension	Denomination
(VARIOUS IN REFERENCE TO THE PALLET SIZE) FLEXIBLE STROKES WITH SERVO MOTOR	(VARIOUS VALUES)	PBC SQUARE 60-80-100-160

PRECISION LINK CONVEYORS

The ITALPLANT Precision Link Conveyor is the carrier used for accurate mounting and operations in the automation field.

It's composed by aluminum beam and chain (other materials up to request), steel guides and rollers greased for life. The structure is modular, according to the customer's needs.

This conveyor is suitable for all the accurate mounting operations that request precision, rigidity, and speed.

The applicable motorizations may provide an intermittent motion - Italplant rotary tables or HER/servo motor with an own motion law - or continuous - HER/servo motor - (page 7).

Features:

- Imperial / Metric versions
- Lightweight structure with an aluminum profile
- Rollers greased for life
- Get And Joint version available (see page 11)
- The squared version available (see page 12)
- Over-Under / Carousel mounting options
- Length and size of the aluminum pallets, other specifications
- General specifications: height, total length, even or odd pallets, disposition

Dimensional evaluation: * If the lateral size of workpiece holder is larger than pallets nominal quote, to avoid the collision with the conveyor corner radius, it's necessary to remove the indicated value - please ask our Technical Department



Available link sizes

3" - 4" - 4.5" - 5.5" - 6" - 100 mm - 125 mm - 150 mm

PLC 3" (76,2 mm)

Link length: 76,2 mm

Centre distance: from 609,6 to 8229,6 mm

Load capacity:

- Every dual pallets: 90 kg
- Every single pallet: 45 kg

Overhung load capacity: 45 Nm

Length deviation: + 0,0127 mm/link

Accuracy:

- **X axis** ± 0,127mm up to 609,6 mm +
± 0,042 mm every 500 mm
- **Y axis** ± 0,127 mm
- **Z axis** ± 0,127 mm

Links tilts displacements:

- **X axis** ± 0,092 mm
- **Y axis** ± 0,060 mm
- **Z axis** ± 0,060 mm

Link overview

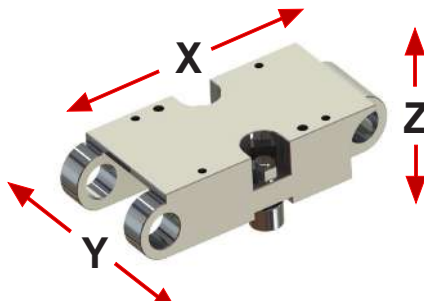

Dimensional evaluation: __mm* (page 21)

Additional features

- 8 pockets sprockets
- Aluminum profile beam
- Squared version available (see page n.30)
- Get And Joint version available
- Over-Under / Carousel mounting options

Optionals on request

- Globoidal Indexer as motorization
- Special Input shaft
- Customized pallets fixing holes
- High temperature pallet version
- Pendular mounting of the motorization
- Legs with X-Y-Z regulation
- Base frame

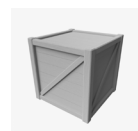
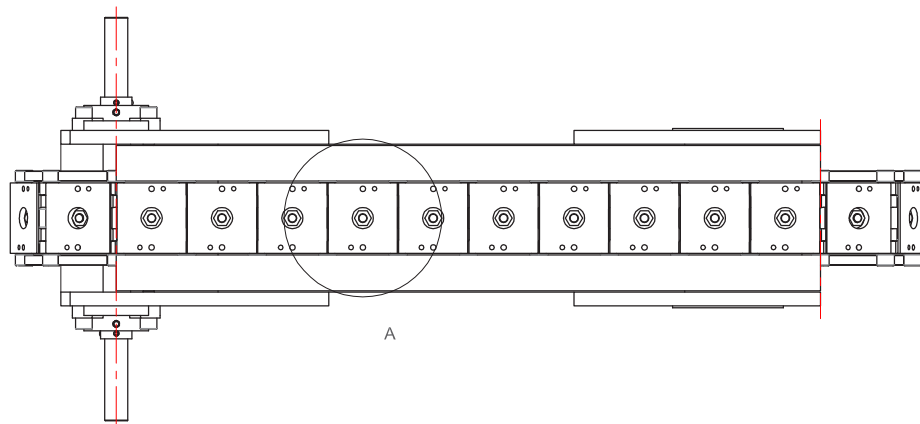
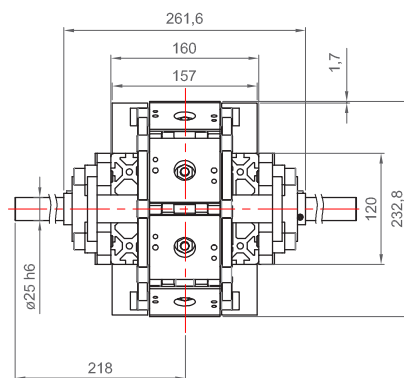
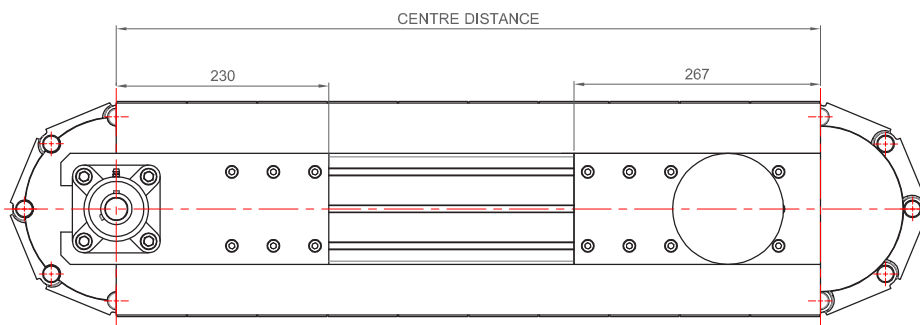
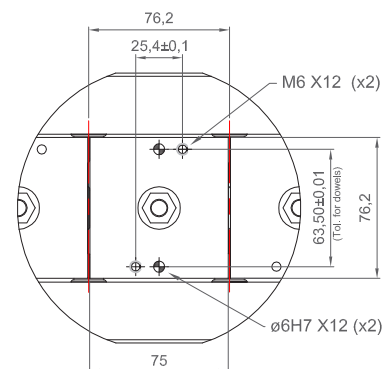

**GET AND JOINT
version available**

Available strokes	Center distance dimension	Denomination
0,75" - 1.5" - 3" - 6" - 9" - 12" - 15" - 18" - 21" - 24" FLEXIBLE STROKES WITH SERVO MOTOR	24" (609,6 mm) to 324" (8229,6 mm)	PLC 3"

PLC 4" (101,6 mm)

Link length: 101,6 mm

Centre distance: from 711,2 to 8229,6 mm

Load capacity:

- **Every dual pallets:** 150 kg
- **Every single pallet:** 75 kg

Overhung load capacity: 130 Nm

Length deviation: + 0,0127 mm/link

Accuracy:

- **X axis** $\pm 0,119$ mm up to 711,2 mm + $\pm 0,021$ mm every 500 mm
- **Y axis** $\pm 0,127$ mm
- **Z axis** $\pm 0,127$ mm

Links tilts displacements:

- **X axis** $\pm 0,092$ mm
- **Y axis** $\pm 0,060$ mm
- **Z axis** $\pm 0,060$ mm

Link overview

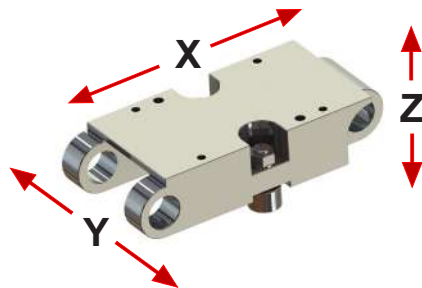

Dimensional evaluation: __mm* (page 21)

Additional features

- 8 pockets sprockets
- Aluminum profile beam
- Squared version available (see page n.30)
- Get And Joint version available
- Over-Under / Carousel mounting options

Optionals on request

- Globoidal Indexer as motorization
- Special Input shaft
- Customized pallets fixing holes
- High temperature pallet version
- Pendular mounting of the motorization
- Legs with X-Y-Z regulation
- Base frame

VIEW FROM "A"

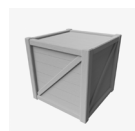
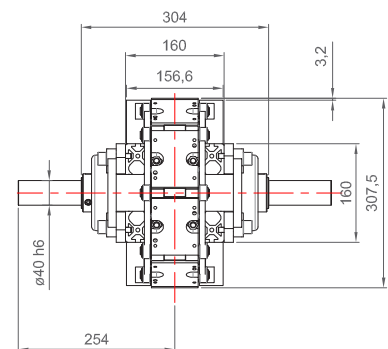
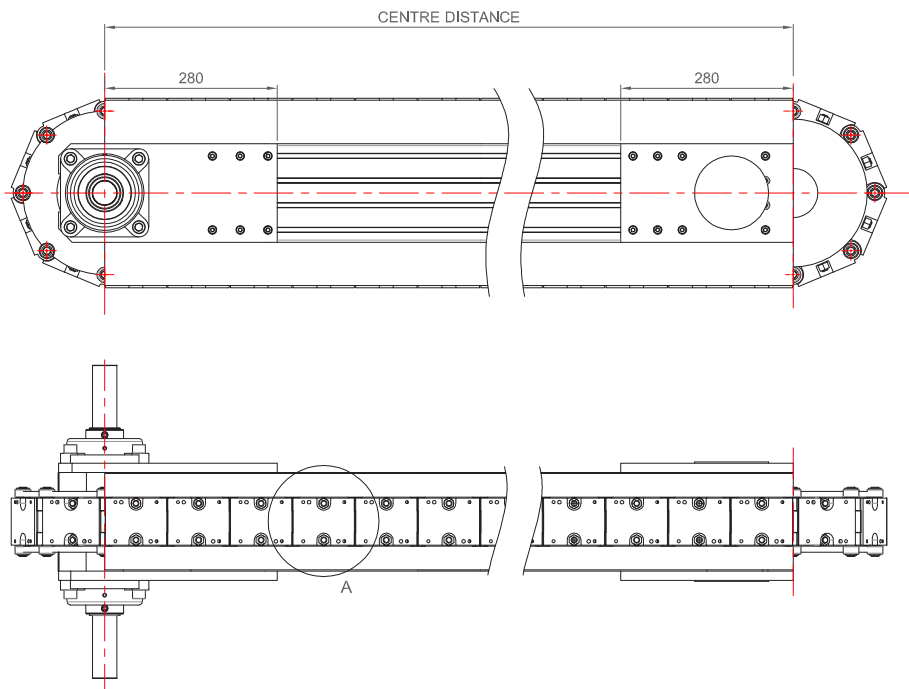
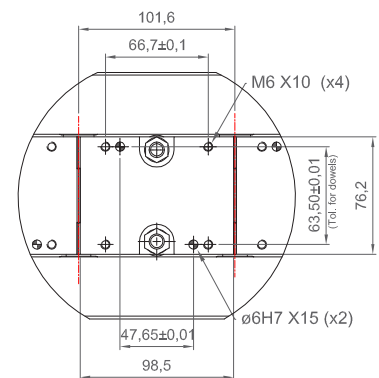

GET AND JOINT
version available

Available strokes	Center distance dimension	Denomination
1" - 2" - 4" - 8" - 12" - 16" - 20" - 24" - 28" - 32" FLEXIBLE STROKES WITH SERVO MOTOR	28" (711,2 mm) to 324" (8229,6 mm)	PLC 4"

PLC 4,5" (114,3 mm)

Link length: 114,3 mm
Centre distance: from 685,8 to 8229,6 mm

Load capacity:

- Every dual pallets: 150 kg
- Every single pallet: 75 kg

Overhung load capacity: 130 Nm

Length deviation: + 0,0127 mm/link

Accuracy:

- **X axis** ± 0,118 mm up to 685,8 mm +
± 0,021 m every 500 mm
- **Y axis** ± 0,127 mm
- **Z axis** ± 0,127 mm

Links tilts displacements:

- **X axis** ± 0,092 mm
- **Y axis** ± 0,060 mm
- **Z axis** ± 0,060 mm

Link overview

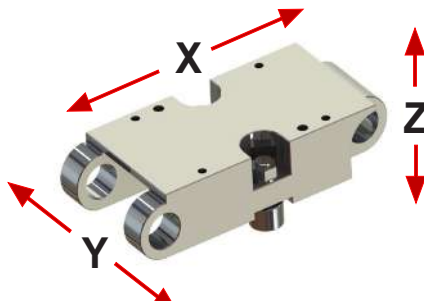

Dimensional evaluation: __mm* (page 21)

Additional features

- 8 pockets sprockets
- Aluminum profile beam
- Squared version available (see page n.30)
- Get And Joint version available
- Over-Under / Carousel mounting options

Optionals on request

- Globoidal Indexer as motorization
- Special Input shaft
- Customized pallets fixing holes
- High temperature pallet version
- Pendular mounting of the motorization
- Legs with X-Y-Z regulation
- Base frame

VIEW FROM "A"

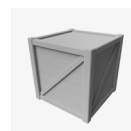
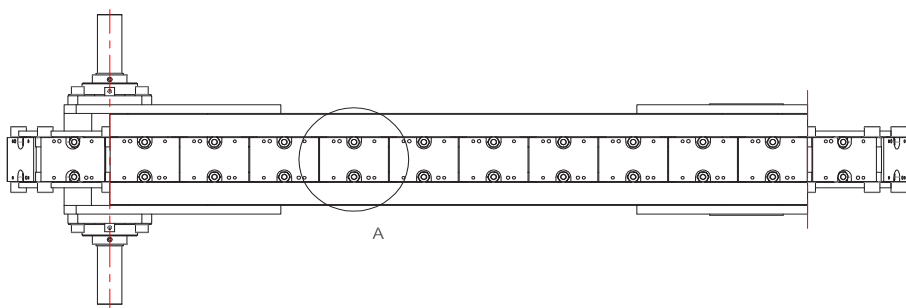
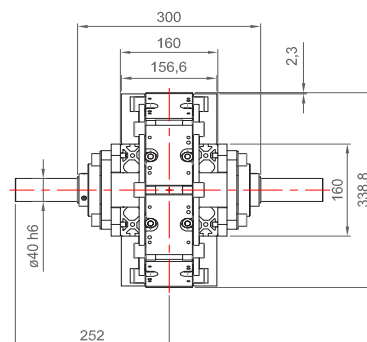
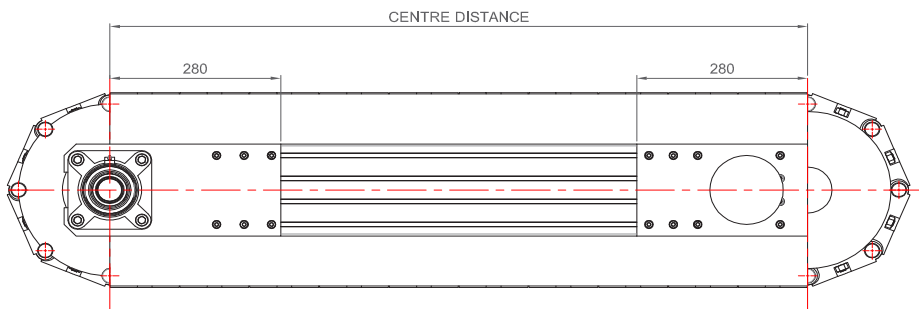
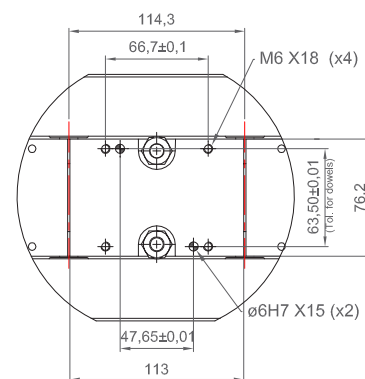

GET AND JOINT
version available

Available strokes	Center distance dimension	Denomination
1,125" - 2,25" - 4,5" - 9" - 13,5" - 18" - 22,5" - 27" - 31,5" - 36" FLEXIBLE STROKES WITH SERVO MOTOR	27" (685,8 mm) to 324" (8229,6 mm)	PLC 4,5"

PLC 5,5" (139,7 mm)

Link length: 139,7 mm

Centre distance: from 698,5 to 8242,3 mm

Load capacity:

- Every dual pallets: 150 kg
- Every single pallet: 75 kg

Overhung load capacity: 130 Nm

Length deviation: + 0,0120 mm/link

Accuracy:

- **X axis** $\pm 0,118$ mm up to 698,5 mm + $\pm 0,021$ mm every 500 mm
- **Y axis** $\pm 0,127$ mm
- **Z axis** $\pm 0,127$ mm

Links tilts displacements:

- **X axis** $\pm 0,092$ mm
- **Y axis** $\pm 0,060$ mm
- **Z axis** $\pm 0,060$ mm

Link overview

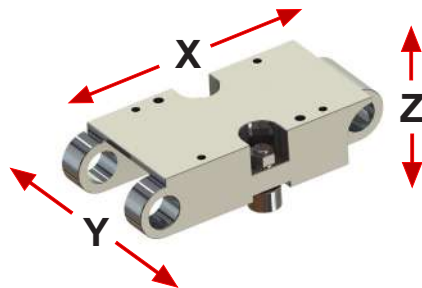

Dimensional evaluation: __mm* (page 21)

Additional features

- 6 pockets sprockets
- Aluminum profile beam
- Squared version available (see page n.30)
- Get And Joint version available
- Over-Under / Carousel mounting options

Optionals on request

- Globoidal Indexer as motorization
- Special Input shaft
- Customized pallets fixing holes
- High temperature pallet version
- Pendular mounting of the motorization
- Legs with X-Y-Z regulation
- Base frame

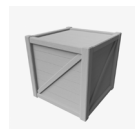
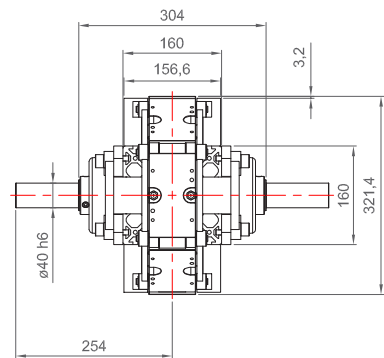
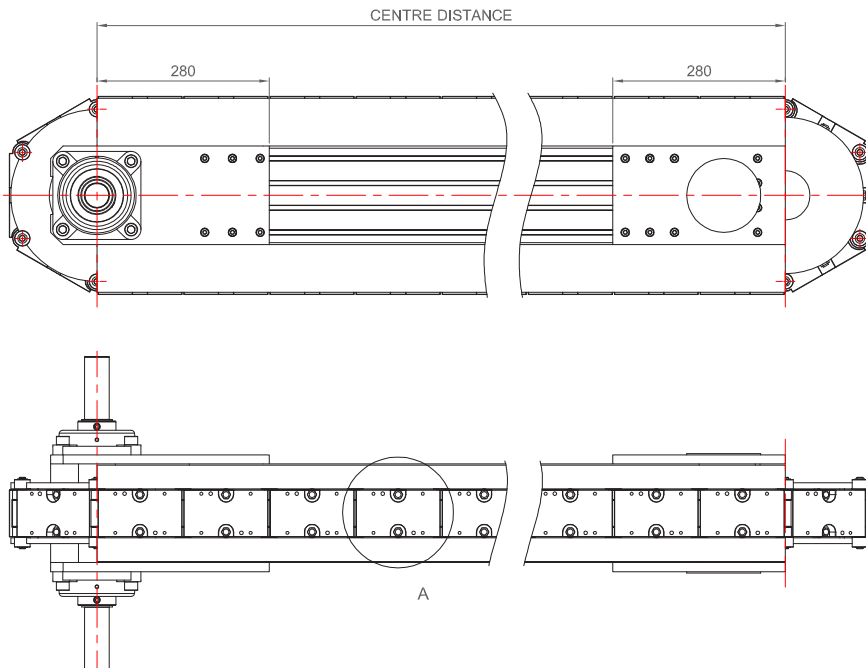
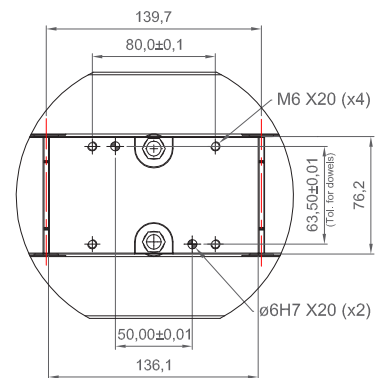

GET AND JOINT
version available

Available strokes	Center distance dimension	Denomination
1,375" - 2,75" - 5,5" - 11" - 16,5" - 22" - 27,5" - 33" FLEXIBLE STROKES WITH SERVO MOTOR	27,5" (698,5 mm) to 324,5" (8242,3 mm)	PLC 5.5"

PLC 6" (152,4 mm)

Link length: 152,4 mm

Centre distance: from 609,6 to 8229,6 mm

Load capacity:

- Every dual pallets: 150 kg
- Every single pallet: 75 kg

Overhung load capacity: 130 Nm

Length deviation: + 0,0120 mm/link

Accuracy:

- **X axis** $\pm 0,115$ mm up to 609,6 mm + $\pm 0,021$ m every 500 mm
- **Y axis** $\pm 0,127$ mm
- **Z axis** $\pm 0,127$ mm

Links tilts displacements:

- **X axis** $\pm 0,092$ mm
- **Y axis** $\pm 0,060$ mm
- **Z axis** $\pm 0,060$ mm

Link overview

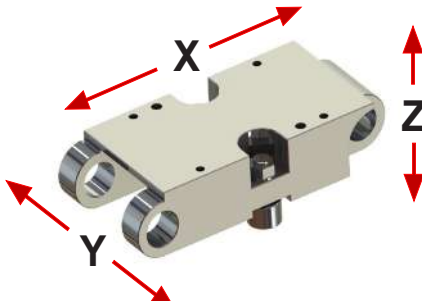

Dimensional evaluation: __mm* (page 21)

Additional features

- 6 pockets sprockets
- Aluminum profile beam
- Squared version available (see page n.30)
- Get And Joint version available
- Over-Under / Carousel mounting options

Optionals on request

- Globoidal Indexer as motorization
- Special Input shaft
- Customized pallets fixing holes
- High temperature pallet version
- Pendular mounting of the motorization
- Legs with X-Y-Z regulation
- Base frame

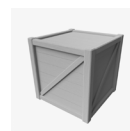
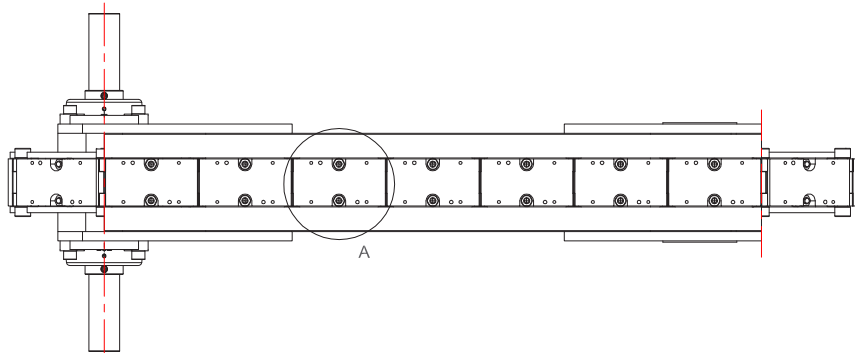
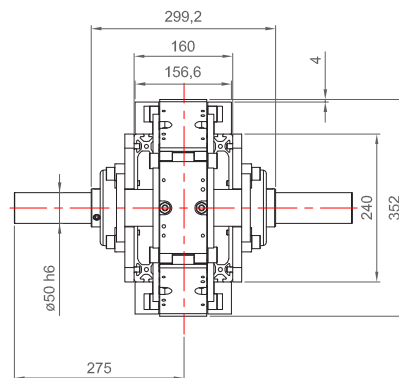
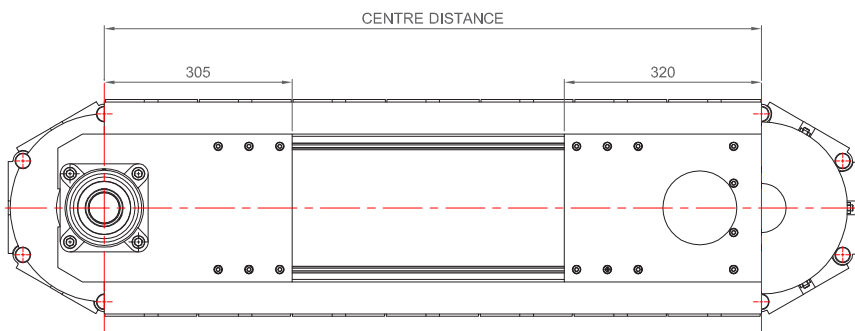
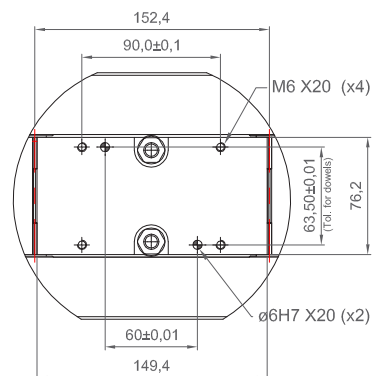

GET AND JOINT
version available

Available strokes	Center distance dimension	Denomination
2" - 3" - 6" - 12" - 18" - 24" - 60" - 36" FLEXIBLE STROKES WITH SERVO MOTOR	24" (609,6 mm) to 324" (8229,6 mm)	PLC 6"

PLC 100 mm

Link length: 100 mm

Centre distance: from 700 to 8200 mm

Load capacity:

- Every dual pallets: 15 kg
- Every single pallet: 75 kg

Overhung load capacity: 130 Nm

Length deviation: + 0,0127 mm/link

Accuracy:

- **X axis** ± 0,119 mm up to 700 mm +
± 0,021 mm every 500 mm
- **Y axis** ± 0,127 mm
- **Z axis** ± 0,127 mm

Links tilts displacements:

- **X axis** ± 0,092 mm
- **Y axis** ± 0,060 mm
- **Z axis** ± 0,060 mm

Link overview

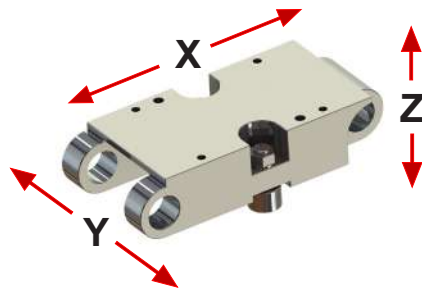

Dimensional evaluation: __mm* (page 21)

Additional features

- 8 pockets sprockets
- Aluminum profile beam
- Squared version available (see page n.30)
- Get And Joint version available
- Over-Under / Carousel mounting options

Optionals on request

- Globoidal Indexer as motorization
- Special Input shaft
- Customized pallets fixing holes
- High temperature pallet version
- Pendular mounting of the motorization
- Legs with X-Y-Z regulation
- Base frame

VIEW FROM "A"

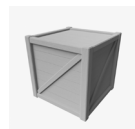
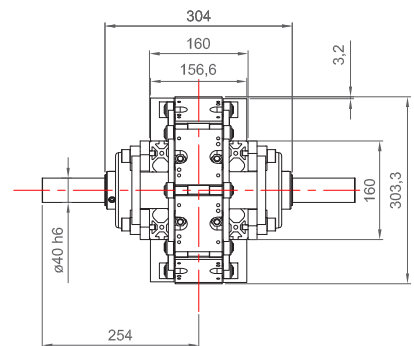
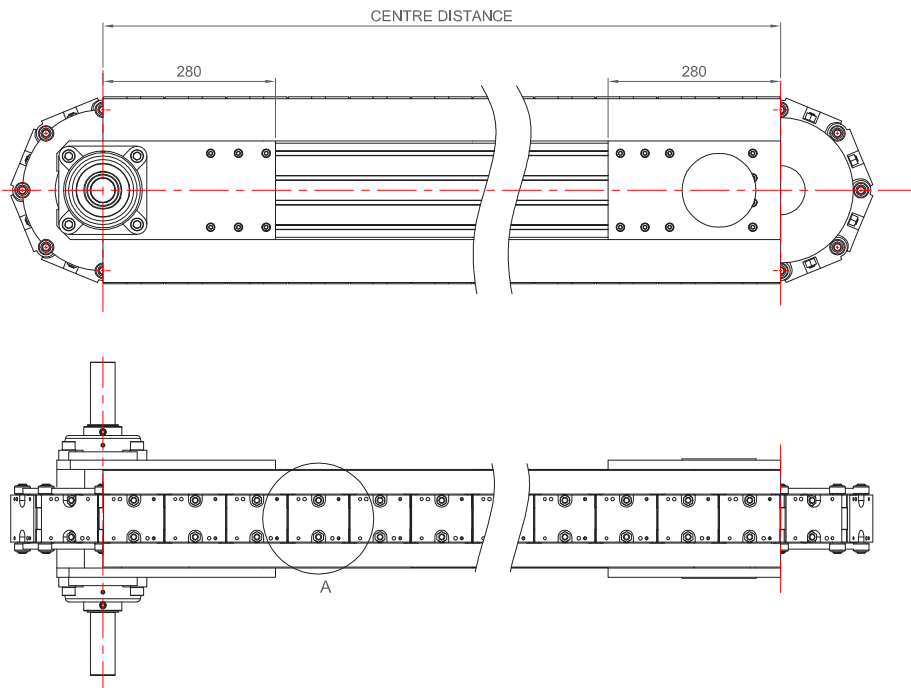
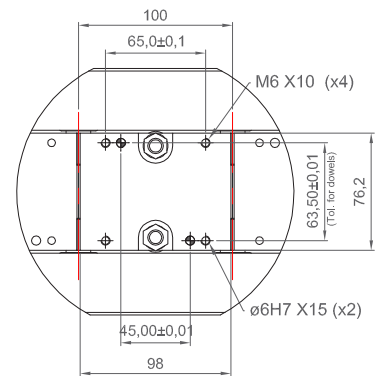

GET AND JOINT
version available

Available strokes	Center distance dimension	Denomination
25 - 50 - 100 - 200 - 300 - 400 - 500 - 600 - 700 - 800 mm FLEXIBLE STROKES WITH SERVOMOTORS	700 mm to 8200 mm	PLC 100

PLC 125 mm

Link length: 125 mm

Centre distance: from 875 to 8250 mm

Load capacity:

- **Every dual pallets:** 150 kg
- **Every single pallet:** 75 kg

Overhung load capacity: 130 Nm

Length deviation: + 0,0127 mm/link

Accuracy:

- **X axis** $\pm 0,126$ mm up to 875 mm + $\pm 0,021$ m every 500 mm
- **Y axis** $\pm 0,127$ mm
- **Z axis** $\pm 0,127$ mm

Links tilts displacements:

- **X axis** $\pm 0,092$ mm
- **Y axis** $\pm 0,060$ mm
- **Z axis** $\pm 0,060$ mm

Link overview

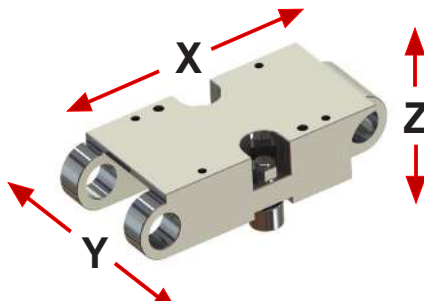

Dimensional evaluatio: __mm* (page 21)

Additional features

- 8 pockets sprockets
- Aluminum profile beam
- Squared version available (see page n.30)
- Get And Joint version available
- Over-Under / Carousel mounting options

Optionals on request

- Globoidal Indexer as motorization
- Special Input shaft
- Customized pallets fixing holes
- High temperature pallet version
- Pendular mounting of the motorization
- Legs with X-Y-Z regulation
- Base frame

VIEW FROM "A"

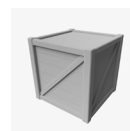
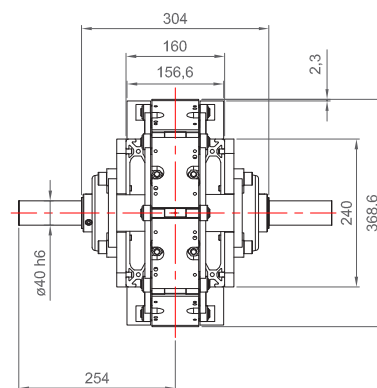
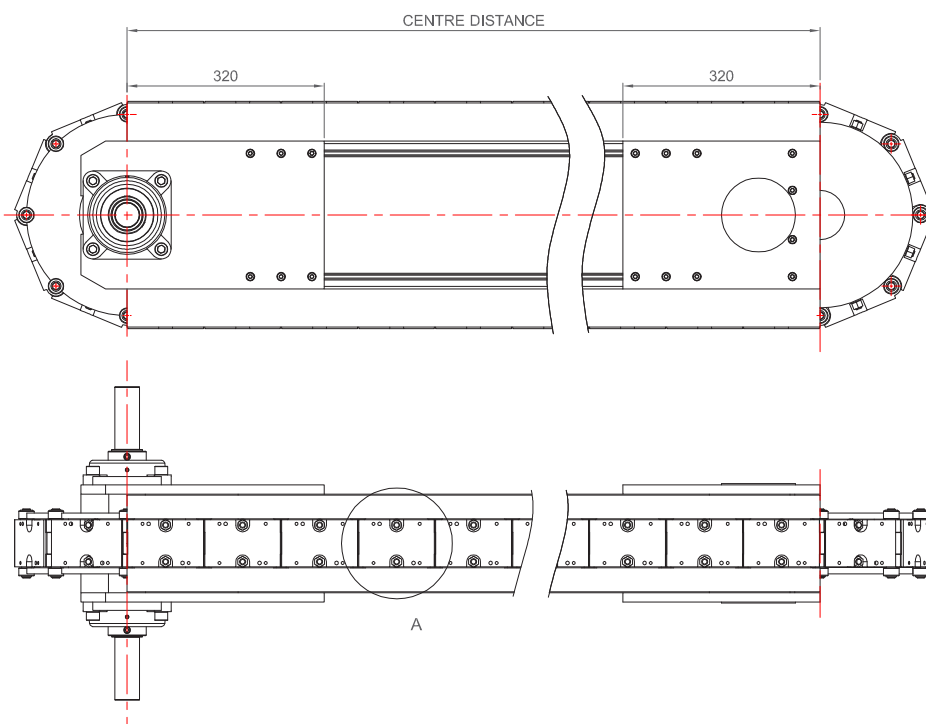
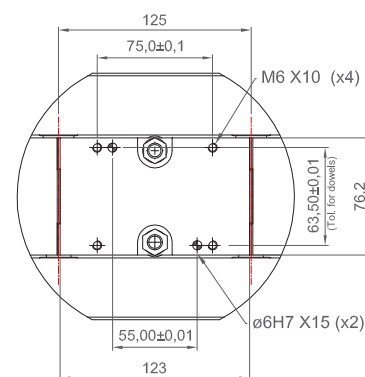

GET AND JOINT
version available

Available strokes	Center distance dimension	Denomination
31,25 - 62,5 - 125 - 250 - 375 - 500 - 625 - 750 - 875 - 1000 mm FLEXIBLE STROKES WITH SERVO MOTOR	875 mm to 8250 mm	PLC 125

PLC 150 mm

Link length: 150 mm

Centre distance: from 900 to 8400 mm

Load capacity:

- Every dual pallets: 150 kg
- Every single pallet: 75 kg

Overhung load capacity: 130 Nm

Length deviation: + 0,0120 mm/link

Accuracy:

- **X axis** $\pm 0,127$ mm up to 900 mm + $\pm 0,021$ mm every 500 mm
- **Y axis** $\pm 0,127$ mm
- **Z axis** $\pm 0,127$ mm

Links tilts displacements:

- **X axis** $\pm 0,092$ mm
- **Y axis** $\pm 0,060$ mm
- **Z axis** $\pm 0,060$ mm

Link overview

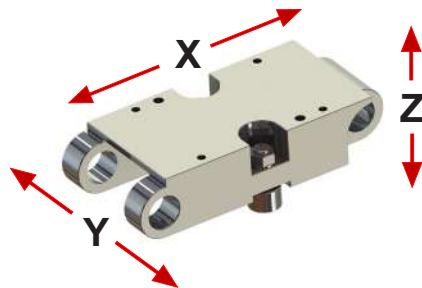

Optionals on request

- Globoidal Indexer as motorization
- Special Input shaft
- Customized pallets fixing holes
- High temperature pallet version
- Pendular mounting of the motorization
- Legs with X-Y-Z regulation
- Base frame

Dimensional evaluation: __mm* (page 21)

Additional features

- 6 pockets sprockets
- Aluminum profile beam
- Squared version available (see page n.30)
- Get And Joint version available
- Over-Under / Carousel mounting options

VIEW FROM "A"

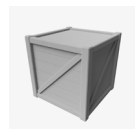
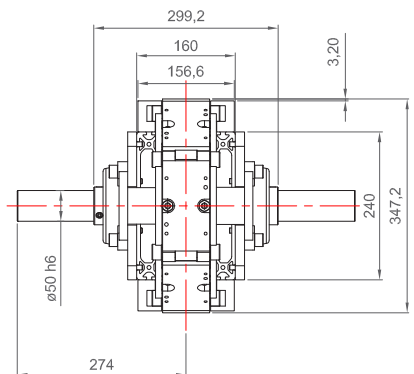
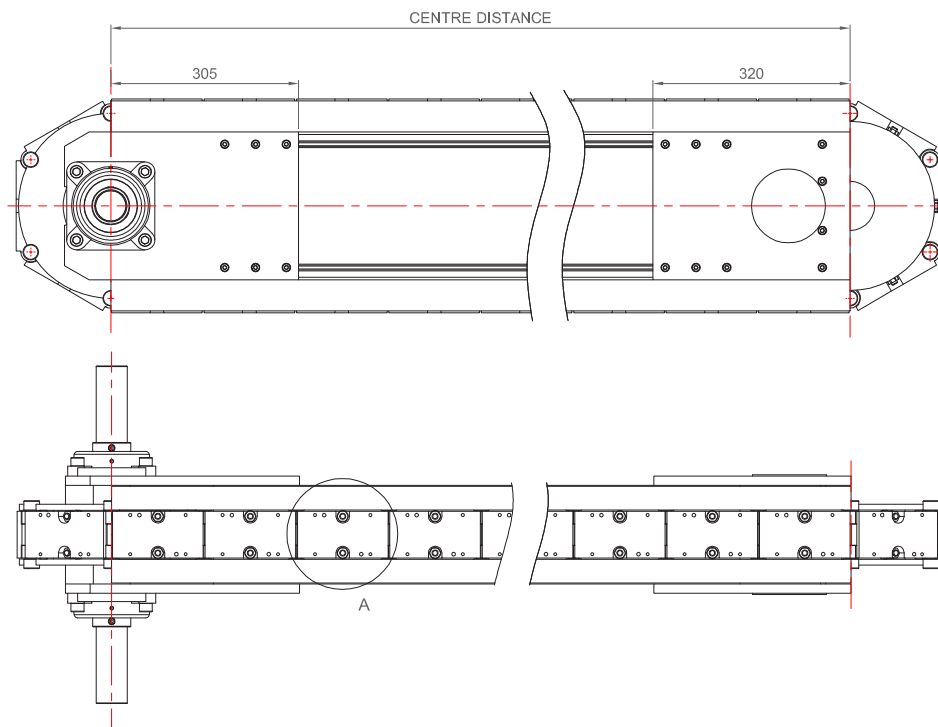
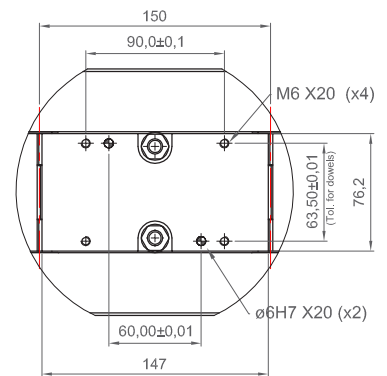

**GET AND JOINT
version available**

Available strokes	Center distance dimension	Denomination
37,5 - 75 - 150 - 300 - 450 - 600 - 750 - 900 mm FLEXIBLE STROKES WITH SERVOMOTORS	900 mm to 8400 mm	PLC 150

PLC SQUARE 3"-4"-4,5"-5,5"-6" - 100-125-150 mm

Link length: 60-80-100-160 mm
Centre distance: (various values)

PLC SQUARE overview

Load capacity: (pages 22-29)
Overhung load capacity: (pages 22-29)

Additional features

- Aluminum profile beam
- Roller follower greased for life
- High overhung load capacity
- Get And Joint version available
- Over-Under / Carousel mounting options

Optionals on request

- Globoidal Indexer as motorization
- Special Input shaft
- Customized pallets fixing holes
- High temperature pallet version
- Pendular mounting of the motorization
- Legs with X-Y-Z regulation
- Base frame

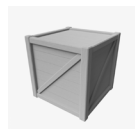
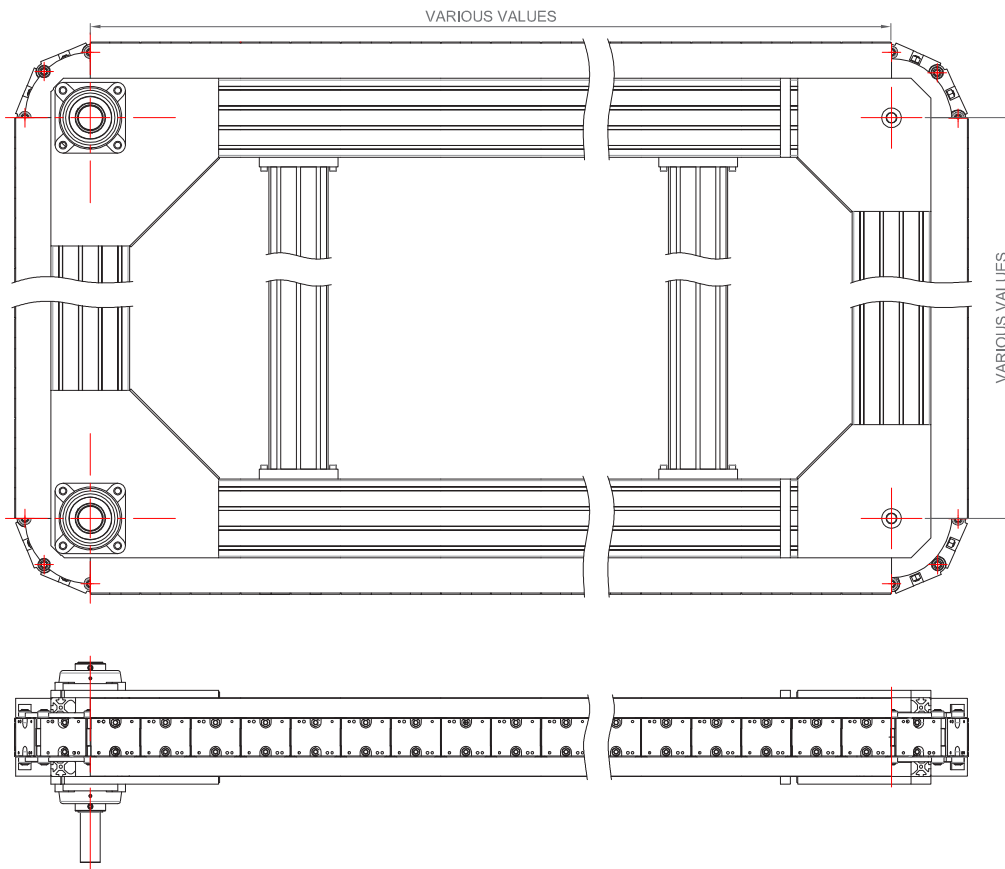
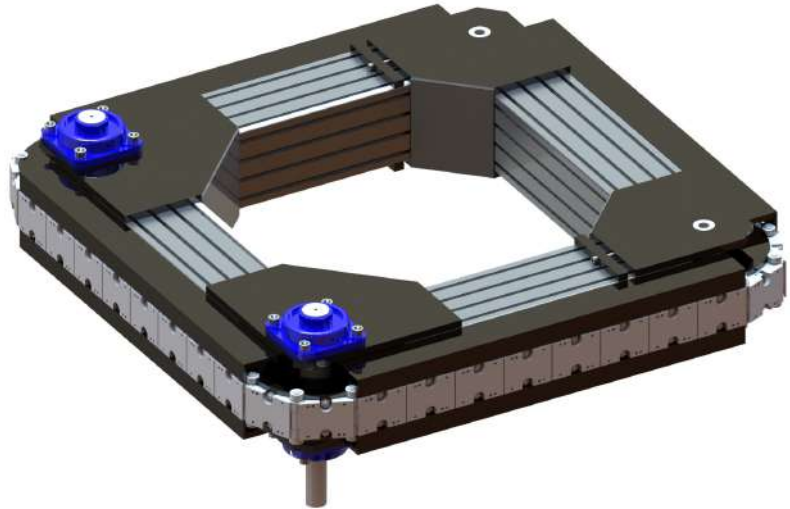

GET AND JOINT
version available

Available strokes	Center distance dimension	Denomination
(VARIOUS IN REFERENCE TO THE LINK SIZE) FLEXIBLE STROKES WITH SERVO MOTOR	(VARIOUS VALUES)	PLC SQUARE 3"-4"-4,5"-5,5" ..

PRECISION LINK CONVEYORS HIGH ACCURACY

The ITALPLANT Precision Link Conveyor is the carrier used for very high accurate mounting and operations in automation and testing fields. It's composed by structural steel beam and aluminum chain (other materials up to request), steel guides and rollers greased for life.

This conveyor is suitable for all the mounting operations that request very high precision, rigidity and speed.

For this type of conveyors, there are two additional variants: the large beam XL version and the Heavy Duty version, suitable for high loads and (automotive applications).

The applicable motorizations may provide an intermittent motion - Italplant rotary tables or HER/servo motor with an own motion law - or continuous - HER/servo motor - (page 7).

Features:

- High repeatability accuracy
- High overhung load capacity
- Imperial / Metric versions
- Structural steel beam with high rigidity
- Rollers greased for life
- Over-Under / Carousel mounting options
- Length and size of the aluminum pallets, other specifications
- General specifications: height, total length, even or odd pallets, dispositions

Dimensional evaluation: * If the lateral size of workpiece holder is larger than pallets nominal quote, to avoid the collision with the conveyor corner radius, it's necessary to remove the indicated value - please ask our Technical Department



Available link sizes

1.5" - 2" - 3" - 4" - 4.5" - 5.5" - 6" - 8" - 12" - 100 mm - 125 mm - 150 mm - 250 mm

PLC HA 1,5" (38,1 mm)

Link length: 31,1 mm

Centre distance: from 228,6 to 5943,6 mm

Load capacity:

- Every dual pallets: 70 kg
- Every single pallet: 35 kg

Overhung load capacity: 20 Nm

Length deviation: + 0,0127 mm/link

Accuracy:

- **X axis** ± 0,039 mm up to 228,6 mm +
± 0,008 m every 500 mm
- **Y axis** ± 0,050 mm
- **Z axis** ± 0,050 mm

Links tilts displacements:

- **X axis** ± 0,076 mm
- **Y axis** ± 0,040 mm
- **Z axis** ± 0,040 mm

Link overview

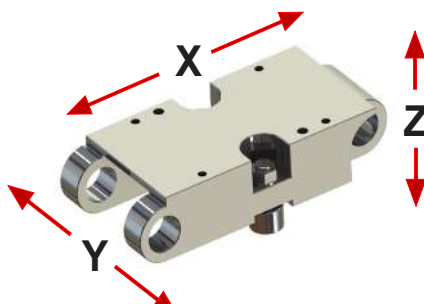

Dimensional evaluation: __mm* (page 31)

Additional features

- 12 pockets sprockets
- Structural steel beam with high rigidity
- High repeatability accuracy
- High overhung load capacity
- Over-Under / Carousel mounting options

Optionals on request

- Globoidal Indexer as motorization
- Special Input shaft
- Customized pallets fixing holes
- High temperature pallet version
- Pendular mounting of the motorization
- Legs with X-Y-Z regulation
- Base frame

VIEW FROM "A"

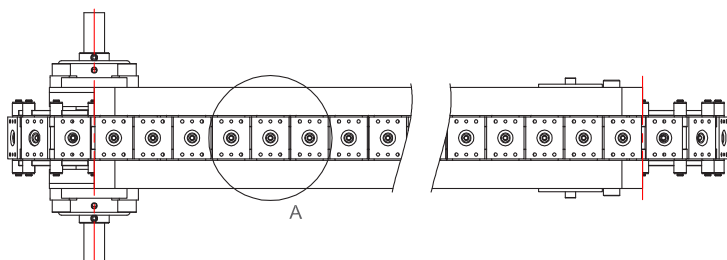
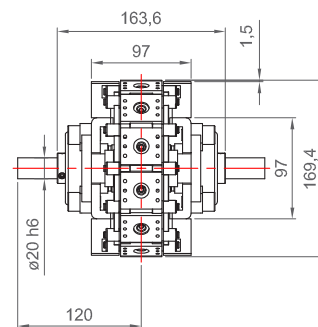
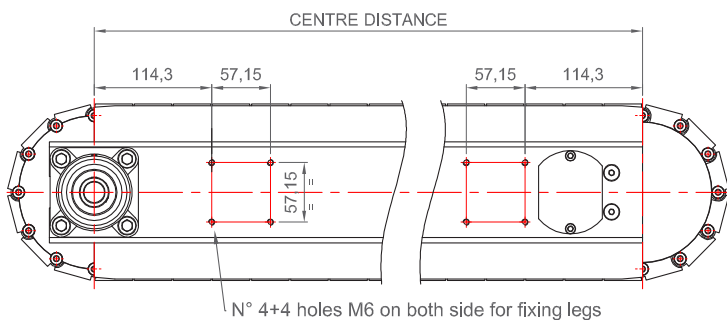
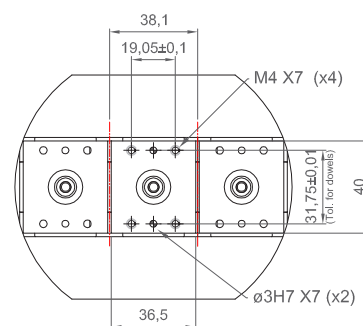

Available strokes	Center distance dimension	Denomination
0,375" - 0,75" - 1,5" - 3" - 4,5" - 6" - 7,5" - 9" - 10,5" - 12" - 13,5" - 15" - 16,5" - 18" FLEXIBLE STROKES WITH SERVO MOTOR	9" (228,6 mm) to 234" (5943,6 mm)	PLC HA 1,5"

PLC HA 2" (50,8 mm)

Link length: 50,8 mm

Centre distance: from 304,8 to 5892,8 mm

Load capacity:

- Every dual pallets: 90 kg
- Every single pallet: 45 kg

Overhung load capacity: 45 Nm

Length deviation: + 0,0127 mm/link

Accuracy:

- **X axis** ± 0,040 mm up to 304,8 mm +
± 0,008 mm every 500 mm
- **Y axis** ± 0,050 mm
- **Z axis** ± 0,050 mm

Links tilts displacements:

- **X axis** ± 0,076 mm
- **Y axis** ± 0,040 mm
- **Z axis** ± 0,040 mm

Link overview

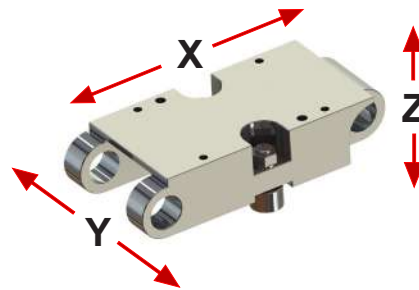

Dimensional evaluation: __mm* (page 31)

Additional features

- 12 pockets sprockets
- Structural steel beam with high rigidity
- High repeatability accuracy
- High overhung load capacity
- Over-Under / Carousel mounting options

Optionals on request

- Globoidal Indexer as motorization
- Special Input shaft
- Customized pallets fixing holes
- High temperature pallet version
- Pendular mounting of the motorization
- Legs with X-Y-Z regulation
- Base frame

VIEW FROM "A"

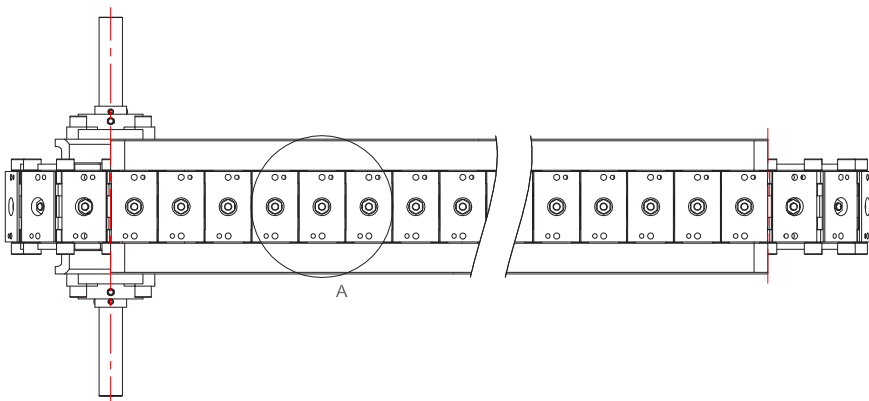
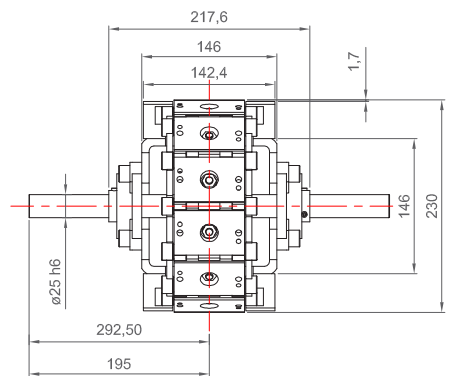
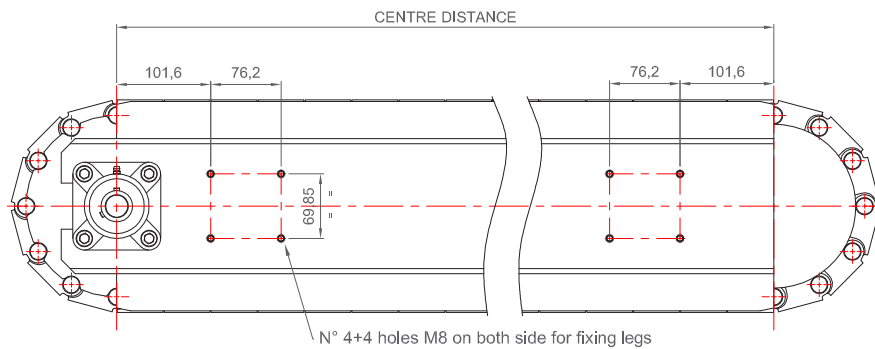
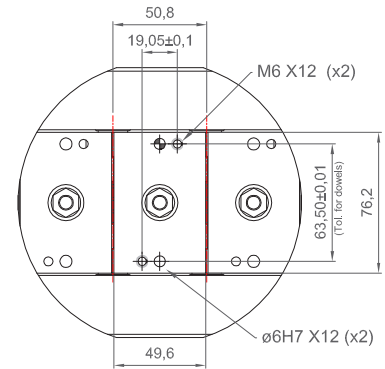

Available strokes	Center distance dimension	Denomination
0,5" - 1" - 2" - 4" - 6" - 8" - 10" - 12" - 14" - 16" - 18" - 20" - 22" - 24" FLEXIBLE STROKES WITH SERVO MOTOR	12" (304,8 mm) to 232" (5892,8 mm)	PLC HA 2"

PLC HA 3" (76,2 mm)

Link length: 76,2 mm

Centre distance: from 381 to 5867,4 mm

Load capacity:

- Every dual pallets: 90 kg
- Every single pallet: 45 kg

Overhung load capacity: 45 Nm

Length deviation: + 0,0127 mm/link

Accuracy:

- **X axis** ± 0,041 mm up to 381 mm +
± 0,008 mm every 500 mm
- **Y axis** ± 0,050 mm
- **Z axis** ± 0,050 mm

Links tilts displacements:

- **X axis** ± 0,076 mm
- **Y axis** ± 0,040 mm
- **Z axis** ± 0,040 mm

Link overview

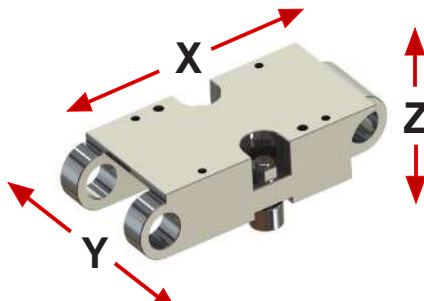

Dimensional evaluation: __mm* (page 31)

Additional features

- 8 pockets sprockets
- Structural steel beam with high rigidity
- High repeatability accuracy
- High overhung load capacity
- Over-Under / Carousel mounting options

Optionals on request

- Globoidal Indexer as motorization
- Special Input shaft
- Customized pallets fixing holes
- High temperature pallet version
- Pendular mounting of the motorization
- Legs with X-Y-Z regulation
- Base frame

VIEW FROM "A"

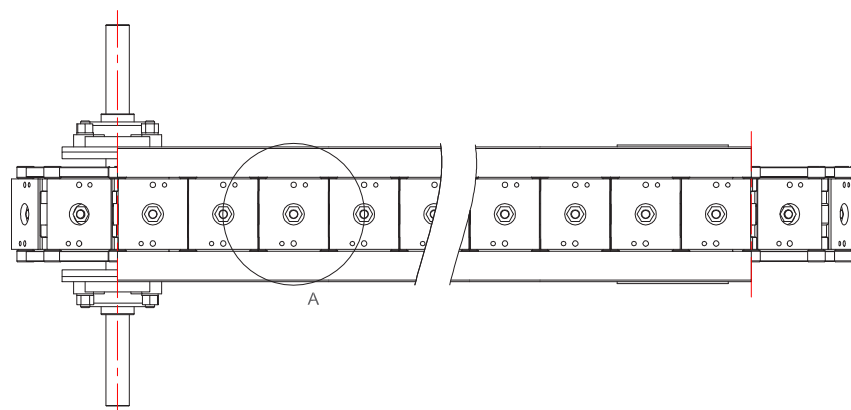
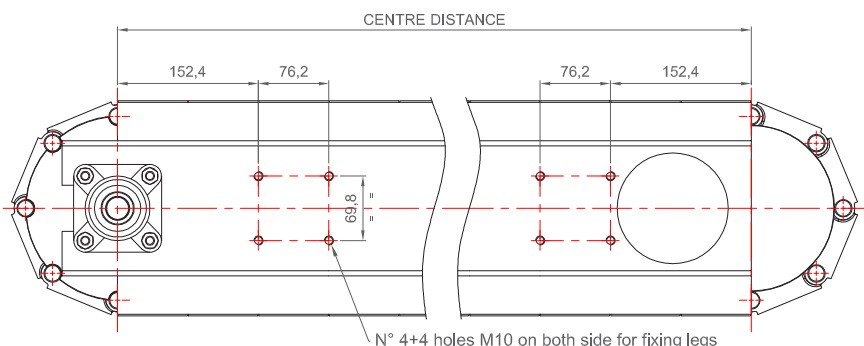
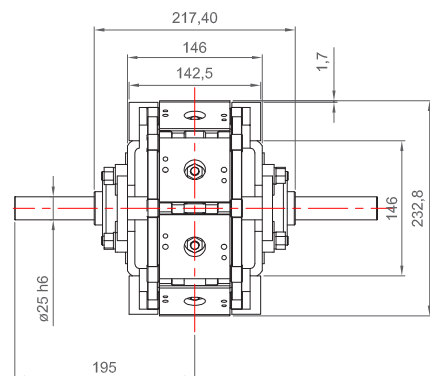
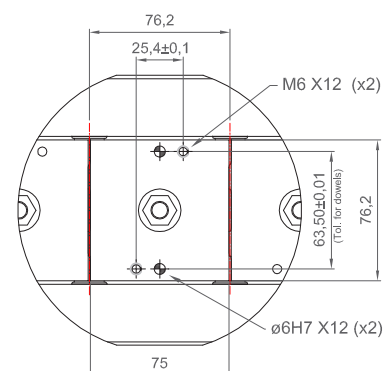

Available strokes	Center distance dimension	Denomination
0,75" - 1.5" - 3" - 6" - 9" - 12" - 15" - 18" - 21" - 24" FLEXIBLE STROKES WITH SERVO MOTOR	15" (381 mm) to 231" (5867,4 mm)	PLC HA 3"

PLC HA 4" (101,6 mm)

Link length: 101,6 mm

Centre distance: from 508 to 11887,2 mm

Load capacity:

- Every dual pallets: 150 kg
- Every single pallet: 75 kg

Overhung load capacity: 130 Nm

Length deviation: + 0,0127 mm/link

Accuracy:

- **X axis** ± 0,035 mm up to 508 mm +
± 0,007 mm every 500 mm
- **Y axis** ± 0,040 mm
- **Z axis** ± 0,040 mm

Links tilts displacements:

- **X axis** ± 0,076 mm
- **Y axis** ± 0,040 mm
- **Z axis** ± 0,040 mm

Link overview

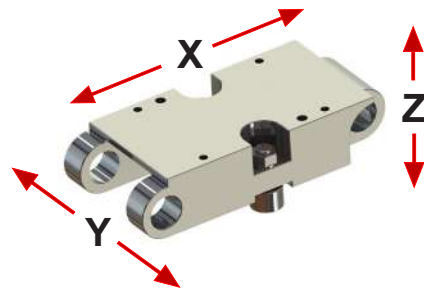

Optionals on request

- Globoidal Indexer as motorization
- Special Input shaft
- Customized pallets fixing holes
- High temperature pallet version
- Pendular mounting of the motorization
- Legs with X-Y-Z regulation
- Base frame

Dimensional evaluation: __mm* (page 31)

Additional features

- 8 pockets sprockets
- Structural steel beam with high rigidity
- High repeatability accuracy
- High overhung load capacity
- Over-Under / Carousel mounting options

VIEW FROM "A"

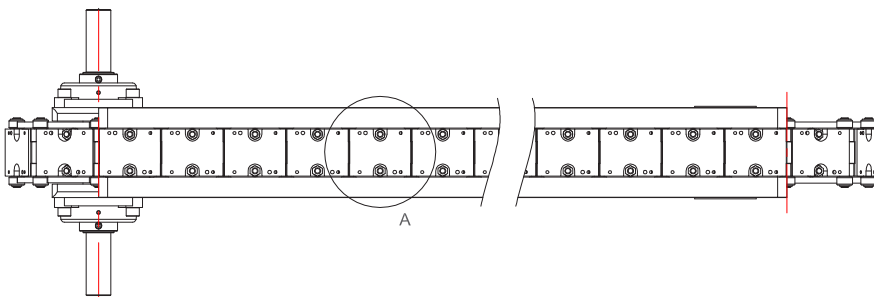
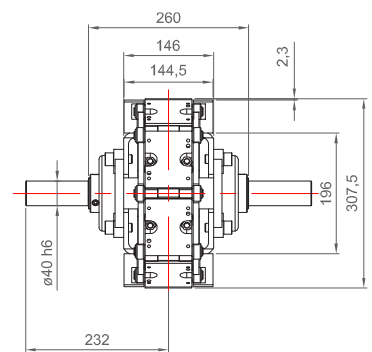
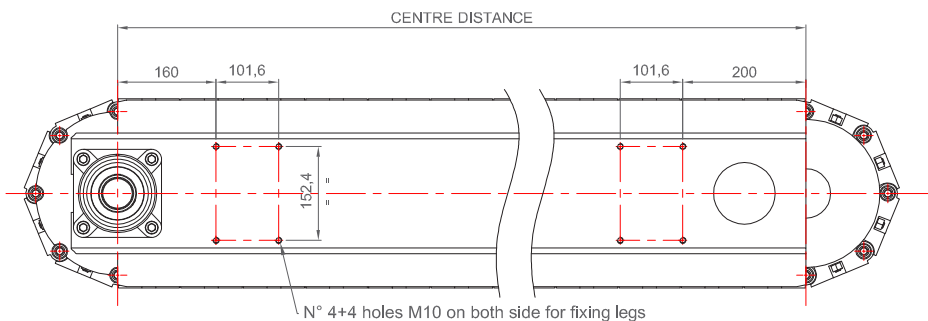
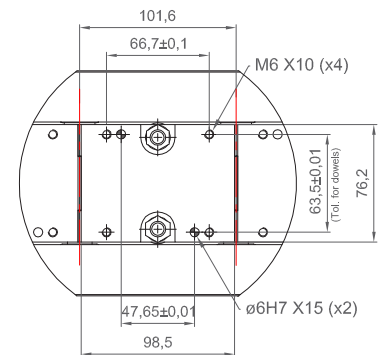

Available strokes	Center distance dimension	Denomination
1" - 2" - 4" - 8" - 12" - 16" - 20" - 24" - 28" - 32" FLEXIBLE STROKES WITH SERVO MOTOR	20" (508 mm) to 468" (11887,2 mm)	PLC HA 4"

PLC HA 4" (101,6 mm) - XL Version

Link length: 101,6 mm

Centre distance: from 609,6 to 11887,2 mm

Load capacity:

- Every dual pallets: 150 kg
- Every single pallet: 75 kg

Overhung load capacity: 130 Nm

Length deviation: + 0,0127 mm/link

Accuracy:

- **X axis** ± 0,040 mm up to 609,6 mm +
± 0,007 m every 500 mm
- **Y axis** ± 0,040 mm
- **Z axis** ± 0,040 mm

Links tilts displacements:

- **X axis** ± 0,076 mm
- **Y axis** ± 0,040 mm
- **Z axis** ± 0,040 mm

Link overview

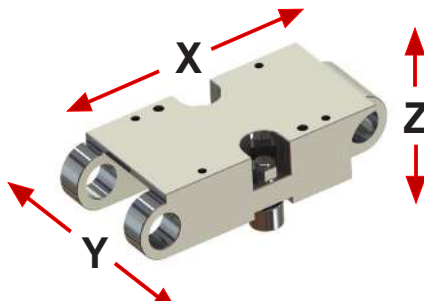

Dimensional evaluation: __mm* (page 31)

Additional features

- 12 pockets sprockets
- Structural steel beam with high rigidity
- High repeatability accuracy
- High overhung load capacity
- Over-Under / Carousel mounting options

Optionals on request

- Globoidal Indexer as motorization
- Special Input shaft
- Customized pallets fixing holes
- High temperature pallet version
- Pendular mounting of the motorization
- Legs with X-Y-Z regulation
- Base frame

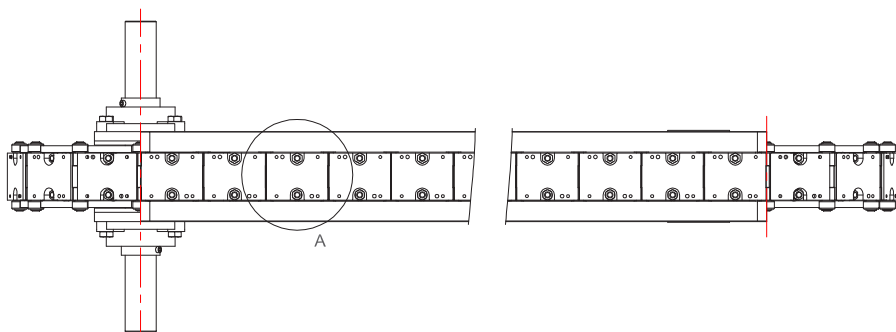
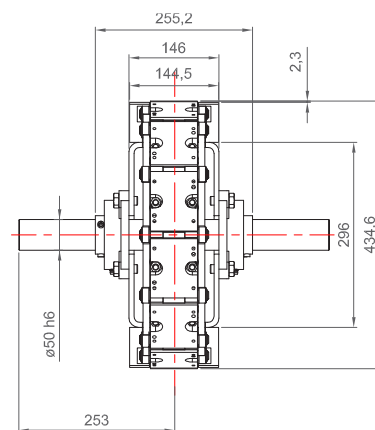
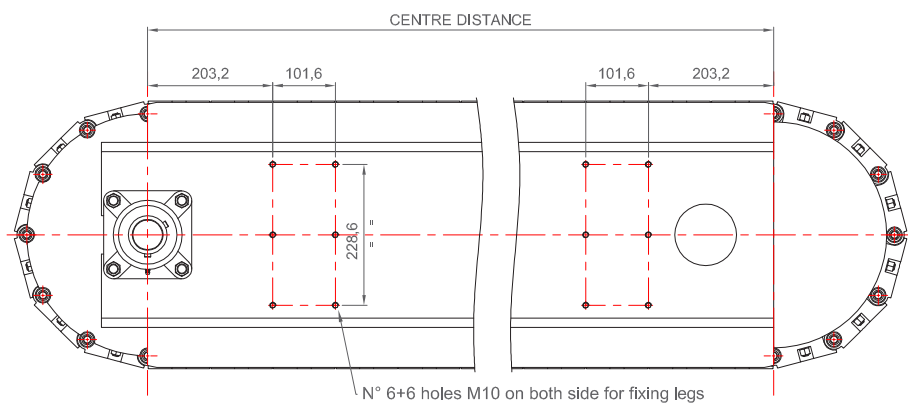
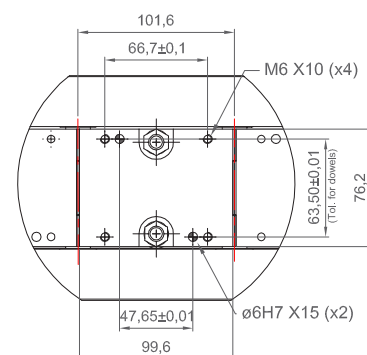

Available strokes	Center distance dimension	Denomination
1" - 2" - 4" - 8" - 12" - 16" - 20" - 24" - 28" - 32" - 36" - 40" - 44" - 48" FLEXIBLE STROKES WITH SERVO MOTOR	24" (609,6 mm) to 468" (11887,2 mm)	PLC HA 4" XL

PLC HA 4,5" (114,3 mm)

Link length: 114,3 mm

Centre distance: from 571,5 to 11887,2 mm

Load capacity:

- Every dual pallets: 150 kg
- Every single pallet: 75 kg

Overhung load capacity: 130 Nm

Length deviation: + 0,0127 mm/link

Accuracy:

- **X axis** ± 0,036 mm up to 571,5 mm +
± 0,007 mm every 500 mm
- **Y axis** ± 0,040 mm
- **Z axis** ± 0,040 mm

Links tilts displacements:

- **X axis** ± 0,076 mm
- **Y axis** ± 0,040 mm
- **Z axis** ± 0,040 mm

Link overview

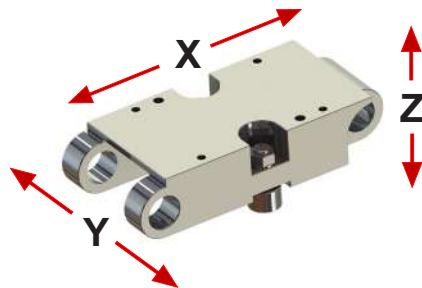

Dimensional evaluation: __mm* (page 31)

Additional features

- 8 pockets sprockets
- Structural steel beam with high rigidity
- High repeatability accuracy
- High overhung load capacity
- Over-Under / Carousel mounting options

Optionals on request

- Globoidal Indexer as motorization
- Special Input shaft
- Customized pallets fixing holes
- High temperature pallet version
- Pendular mounting of the motorization
- Legs with X-Y-Z regulation
- Base frame

VIEW FROM "A"

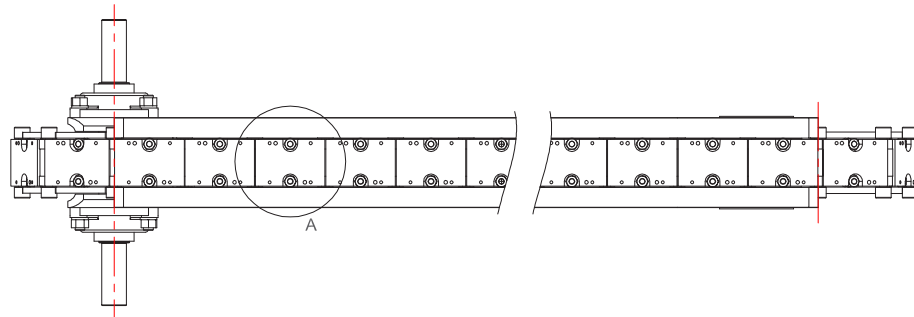
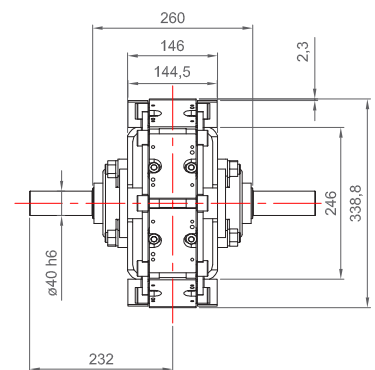
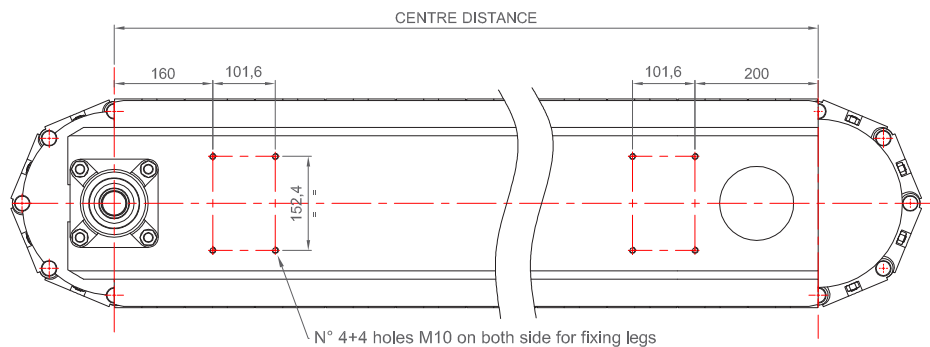
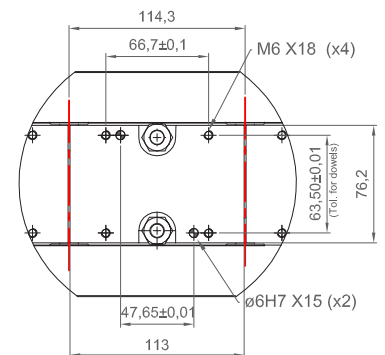

Available strokes	Center distance dimension	Denomination
1,125" - 2,25" - 4,5" - 9" - 13,5" - 18" - 22,5" - 27" - 31,5" - 36" FLEXIBLE STROKES WITH SERVO MOTOR	22,5" (571,5 mm) to 468" (11887,2 mm)	PLC HA 4.5"

PLC HA 5,5" (139,7 mm)

Link length: 139,7 mm
Centre distance: from 558,8 to 11874,5 mm

Load capacity:

- Every dual pallets: 150 kg
- Every single pallet: 75 kg

Overhung load capacity: 130 Nm

Length deviation: + 0,0120 mm/link

Accuracy:

- **X axis** ± 0,035 mm up to 558,8 mm +
± 0,007 mm every 500 mm
- **Y axis** ± 0,040 mm
- **Z axis** ± 0,040 mm

Links tilts displacements:

- **X axis** ± 0,076 mm
- **Y axis** ± 0,040 mm
- **Z axis** ± 0,040 mm

Link overview

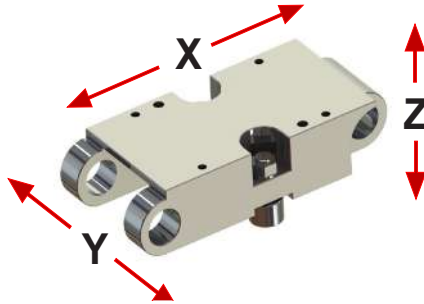

Dimensional evaluation: __mm* (page 31)

Additional features

- 6 pockets sprockets
- Structural steel beam with high rigidity
- High repeatability accuracy
- High overhung load capacity
- Over-Under / Carousel mounting options

Optionals on request

- Globoidal Indexer as motorization
- Special Input shaft
- Customized pallets fixing holes
- High temperature pallet version
- Pendular mounting of the motorization
- Legs with X-Y-Z regulation
- Base frame

VIEW FROM "A"

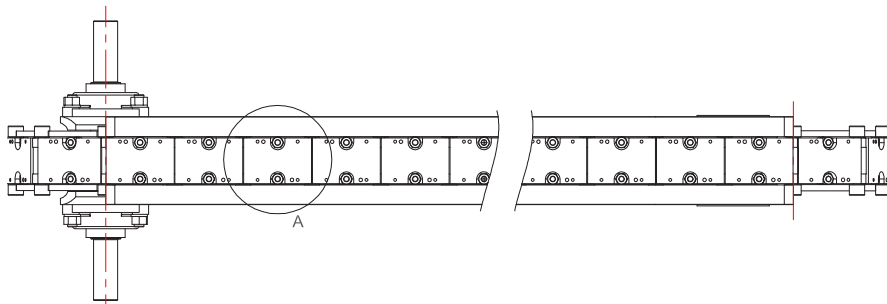
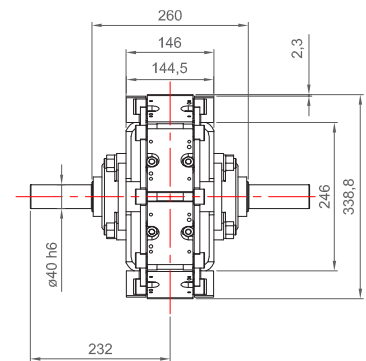
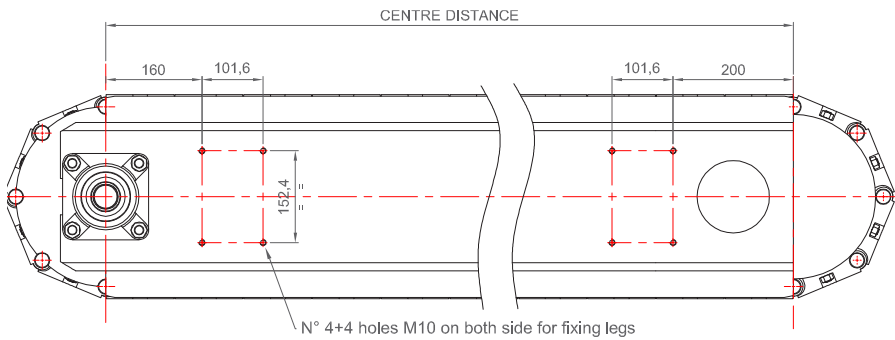
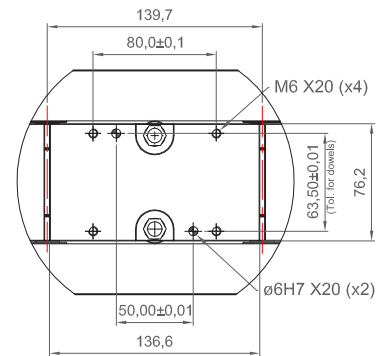

Available strokes	Center distance dimension	Denomination
1,375" - 2,75" - 5,5" - 11" - 16,5" - 22" - 27,5" - 33" FLEXIBLE STROKES WITH SERVO MOTOR	22" (558,8 mm) to 467,5" (11874,5 mm)	PLC HA 5,5"

PLC HA 6" (152,4 mm)

Link length: 152,4 mm

Centre distance: from 609,6 to 11887,2 mm

Load capacity:

- **Every dual pallets:** 150 kg
- **Every single pallet:** 75 kg

Overhung load capacity: 130 Nm

Length deviation: + 0,0120 mm/link

Accuracy:

- **X axis** $\pm 0,036$ mm up to 609,6 mm + $\pm 0,007$ mm every 500 mm
- **Y axis** $\pm 0,040$ mm
- **Z axis** $\pm 0,040$ mm

Links tilts displacements:

- **X axis** $\pm 0,076$ mm
- **Y axis** $\pm 0,040$ mm
- **Z axis** $\pm 0,040$ mm

Link overview

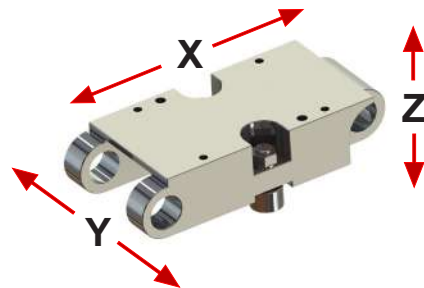

Dimensional evaluation: __mm* (page 31)

Additional features

- 6 pockets sprockets
- Structural steel beam with high rigidity
- High repeatability accuracy
- High overhung load capacity
- Over-Under / Carousel mounting options

Optionals on request

- Globoidal Indexer as motorization
- Special Input shaft
- Customized pallets fixing holes
- High temperature pallet version
- Pendular mounting of the motorization
- Legs with X-Y-Z regulation
- Base frame

VIEW FROM "A"

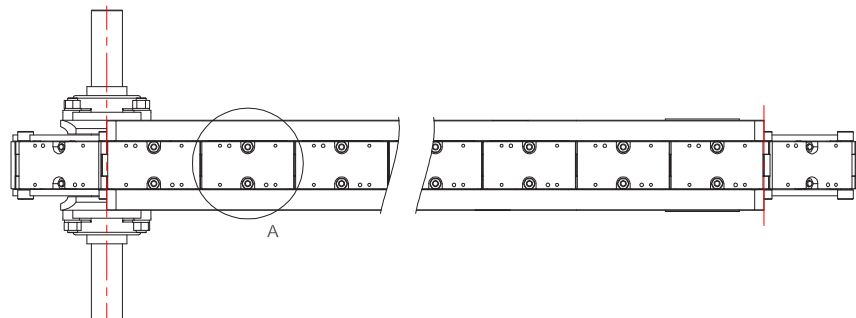
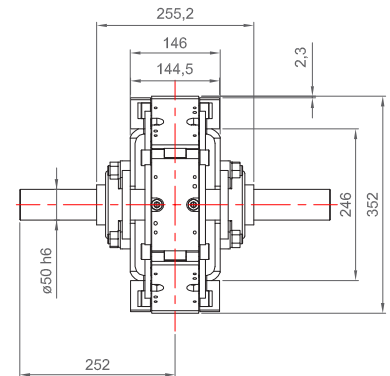
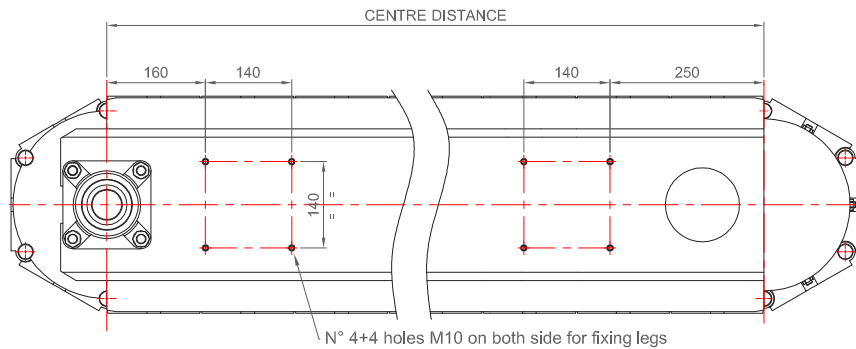
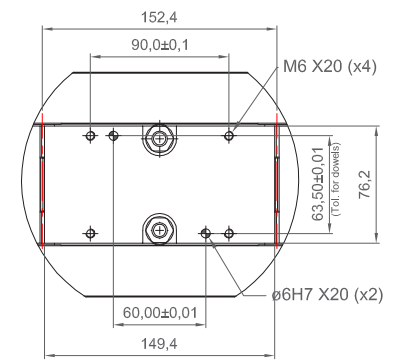

Available strokes	Center distance dimension	Denomination
2" - 3" - 6" - 12" - 18" - 24" - 60" - 36" FLEXIBLE STROKES WITH SERVO MOTOR	24" (609,6 mm) to 468" (11887,2 mm)	PLC HA 6"

PLC HA 8" (203,2 mm) - HEAVY DUTY Version

Link length: 203,2 mm

Centre distance: from 812,8 to 11785,6 mm

Load capacity:

- Every dual pallets: 150 kg
- Every single pallet: 75 kg

Overhung load capacity: 180 Nm

Length deviation: + 0,0120 mm/link

Accuracy:

- **X axis** $\pm 0,043$ mm up to 812,8 mm + $\pm 0,007$ m every 500 mm
- **Y axis** $\pm 0,040$ mm
- **Z axis** $\pm 0,040$ mm

Links tilts displacements:

- **X axis** $\pm 0,076$ mm
- **Y axis** $\pm 0,040$ mm
- **Z axis** $\pm 0,040$ mm

Link overview

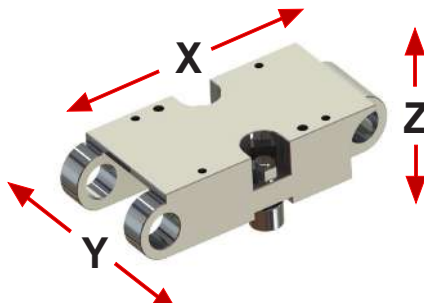

Dimensional evaluation: __mm* (page 31)

Additional features

- 8 pockets sprockets
- Structural steel beam with high rigidity
- High repeatability accuracy
- High overhung load capacity
- Over-Under / Carousel mounting options

Optionals on request

- Globoidal Indexer as motorization
- Special Input shaft
- Customized pallets fixing holes
- High temperature pallet version
- Pendular mounting of the motorization
- Legs with X-Y-Z regulation
- Base frame

VIEW FROM "A"

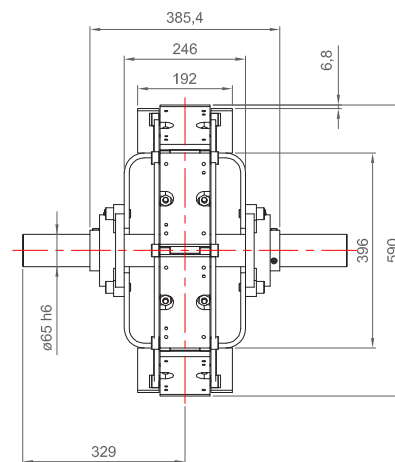
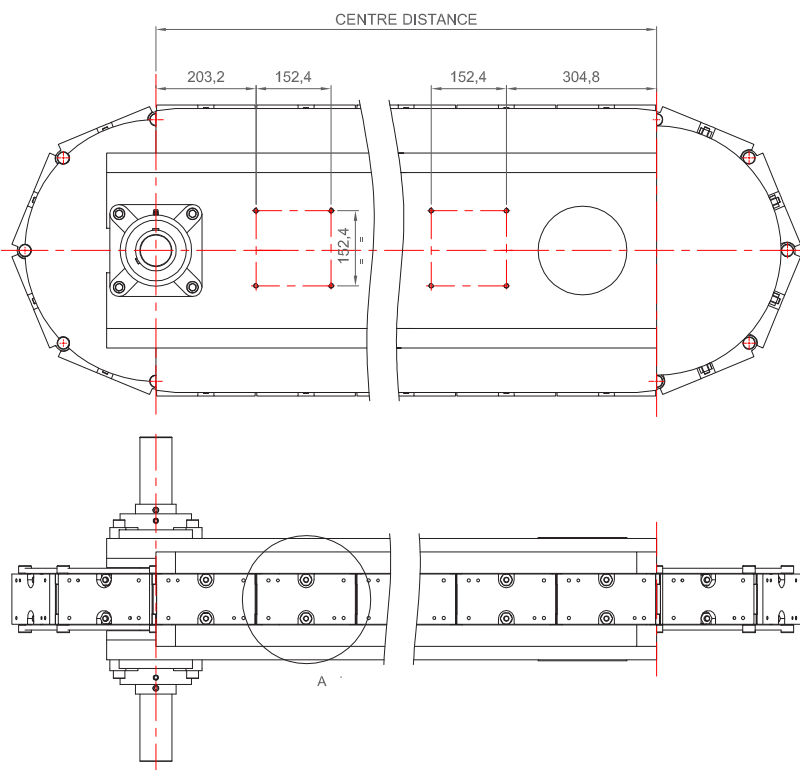
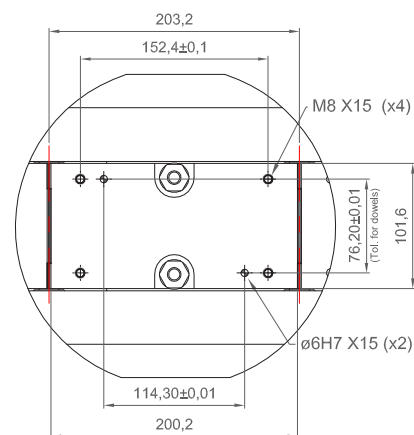

Available strokes	Center distance dimension	Denomination
2" - 4" - 8" - 16" - 24" - 32" - 40" - 48" - 56" - 64" FLEXIBLE STROKES WITH SERVO MOTOR	32" (812,8 mm) to 464" (11785,6 mm)	PLC HA 8"

PLC HA 12" (304,8 mm) - HEAVY DUTY Version

Link length: 304,8 mm

Centre distance: from 1219,2 to 11887,2 mm

Load capacity:

- Every dual pallets: 150 kg
- Every single pallet: 75 kg

Overhung load capacity: 180 Nm

Length deviation: + 0,0120 mm/link

Accuracy:

- **X axis** $\pm 0,049$ mm up to 1219,2 mm + $\pm 0,007$ mm every 500 mm
- **Y axis** $\pm 0,040$ mm
- **Z axis** $\pm 0,040$ mm

Links tilts displacements:

- **X axis** $\pm 0,076$ mm
- **Y axis** $\pm 0,040$ mm
- **Z axis** $\pm 0,040$ mm

Link overview

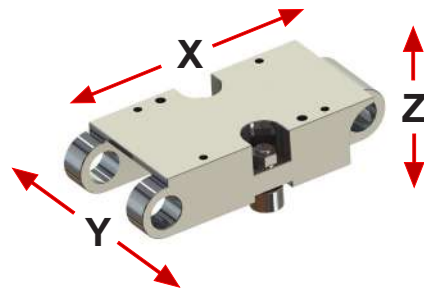

Optionals on request

- Globoidal Indexer as motorization
- Special Input shaft
- Customized pallets fixing holes
- High temperature pallet version
- Pendular mounting of the motorization
- Legs with X-Y-Z regulation
- Base frame

Dimensional evaluation: __mm* (page 31)

Additional features

- 8 pockets sprockets
- Structural steel beam with high rigidity
- High repeatability accuracy
- High overhung load capacity
- Over-Under / Carousel mounting options

VIEW FROM "A"

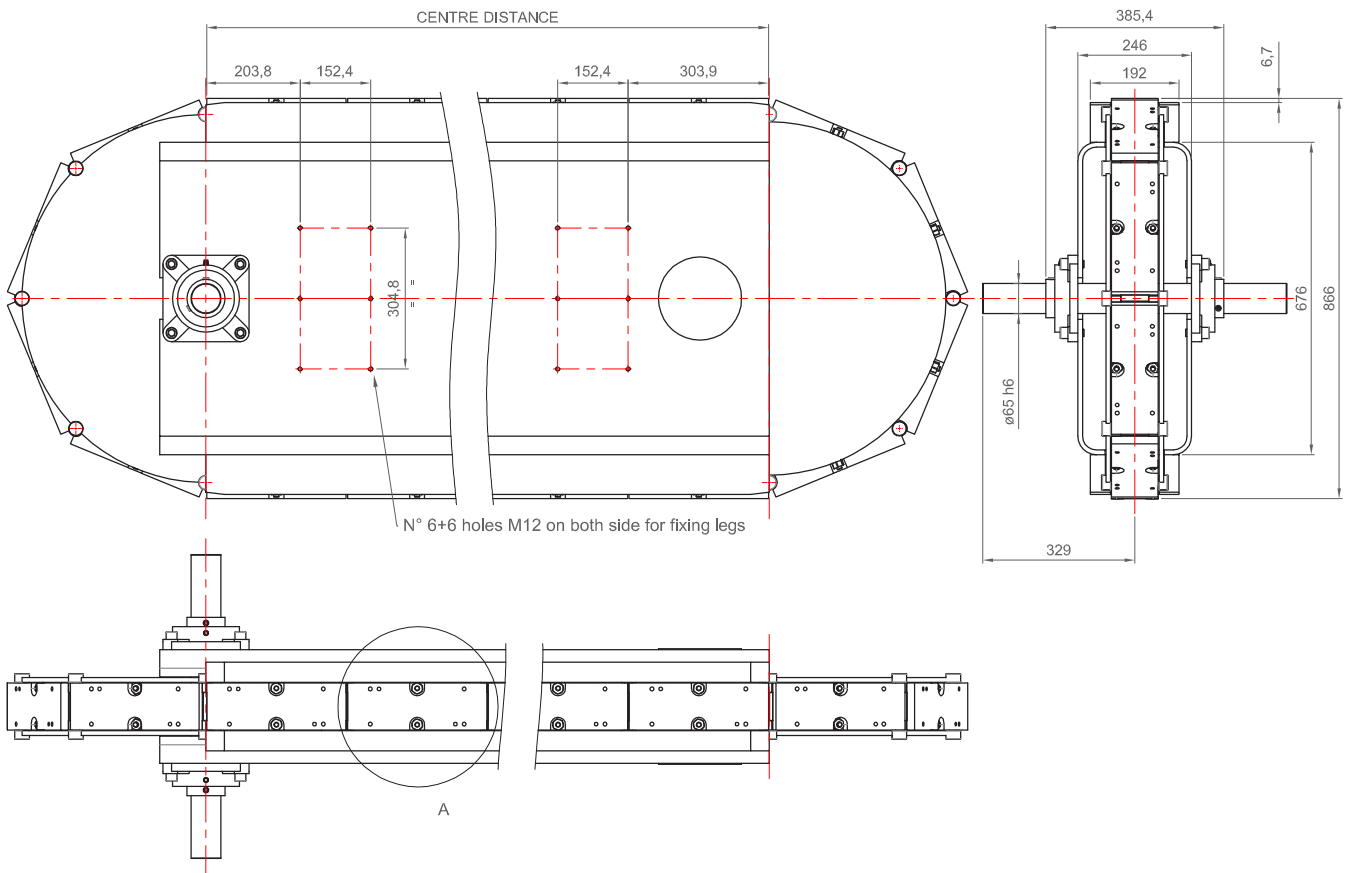
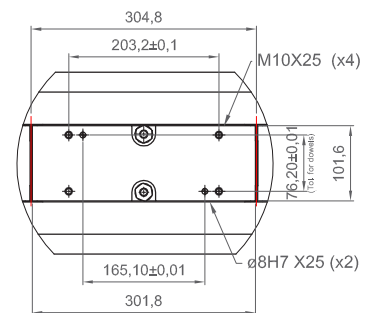

Available strokes	Center distance dimension	Denomination
3" - 6" - 12" - 24" - 36" - 48" - 60" - 72" - 84" - 96" FLEXIBLE STROKES WITH SERVOMOTORS	48" (1219,2 mm) to 468" (11887,2 mm)	PLC HA 12"

PLC HA 100 mm

Link length: 100 mm
Centre distance: from 500 to 11900 mm

Load capacity:

- **Every dual pallets:** 150 kg
- **Every single pallet:** 75 kg

Overhung load capacity: 130 Nm

Length deviation: + 0,0127 mm/link

Accuracy:

- **X axis** ± 0,035 mm up to 500 mm +
± 0,007 mm every 500 mm
- **Y axis** ± 0,040 mm
- **Z axis** ± 0,040 mm

Links tilts displacements:

- **X axis** ± 0,076 mm
- **Y axis** ± 0,040 mm
- **Z axis** ± 0,040 mm

Link overview

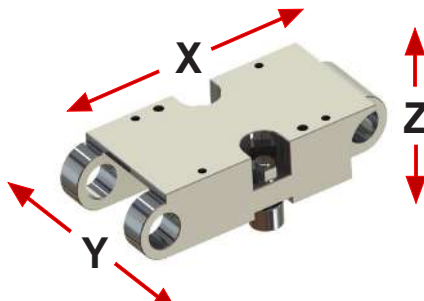

Dimensional evaluation: __mm* (page 31)

Additional features

- 8 pockets sprockets
- Structural steel beam with high rigidity
- High repeatability accuracy
- High overhung load capacity
- Over-Under / Carousel mounting options

Optionals on request

- Globoidal Indexer as motorization
- Special Input shaft
- Customized pallets fixing holes
- High temperature pallet version
- Pendular mounting of the motorization
- Legs with X-Y-Z regulation
- Base frame

VIEW FROM "A"

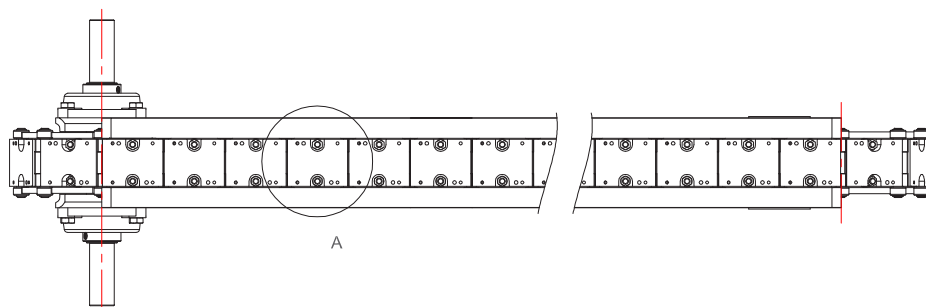
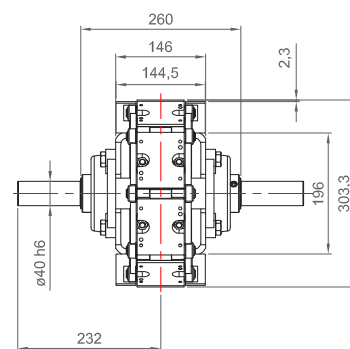
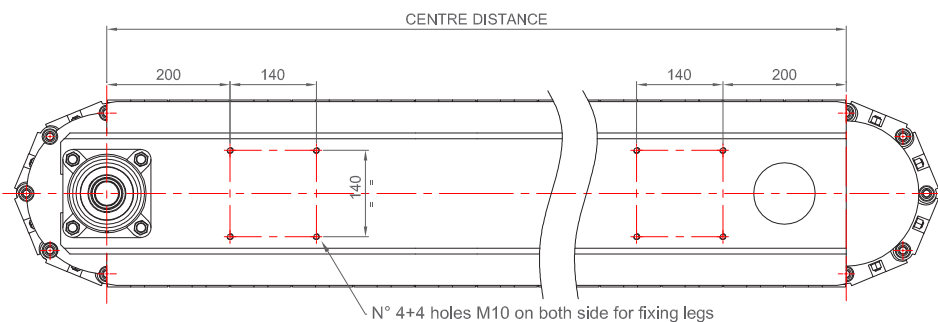
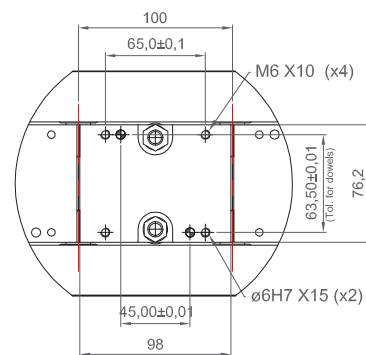

Available strokes	Center distance dimension	Denomination
25 - 50 - 100 - 200 - 300 - 400 - 500 - 600 - 700 - 800 mm FLEXIBLE STROKES WITH SERVO MOTOR	500 mm to 11900 mm	PLC HA 100

PLC HA 125 mm

Link length: 125 mm

Centre distance: from 500 to 11875 mm

Load capacity:

- Every dual pallets: 150 kg
- Every single pallet: 75 kg

Overhung load capacity: 130 Nm

Length deviation: + 0,0127 mm/link

Accuracy:

- **X axis** ± 0,035 mm up to 500 mm + ± 0,007 mm every 500 mm
- **Y axis** ± 0,040 mm
- **Z axis** ± 0,040 mm

Links tilts displacements:

- **X axis** ± 0,076 mm
- **Y axis** ± 0,040 mm
- **Z axis** ± 0,040 mm

Link overview

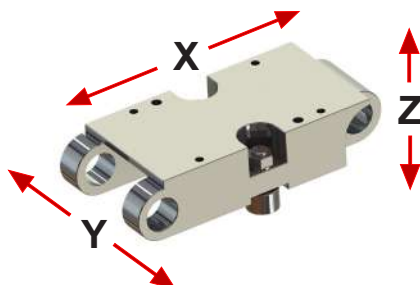

Optionals on request

- Globoidal Indexer as motorization
- Special Input shaft
- Customized pallets fixing holes
- High temperature pallet version
- Pendular mounting of the motorization
- Legs with X-Y-Z regulation
- Base frame

Dimensional evaluation: __mm* (page 31)

Additional features

- 8 pockets sprockets
- Structural steel beam with high rigidity
- High repeatability accuracy
- High overhung load capacity
- Over-Under / Carousel mounting options

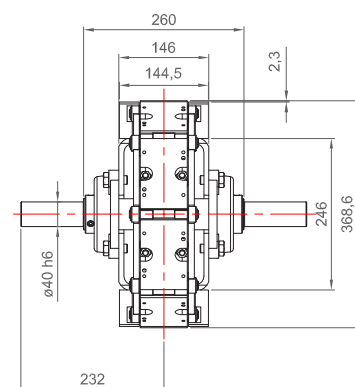
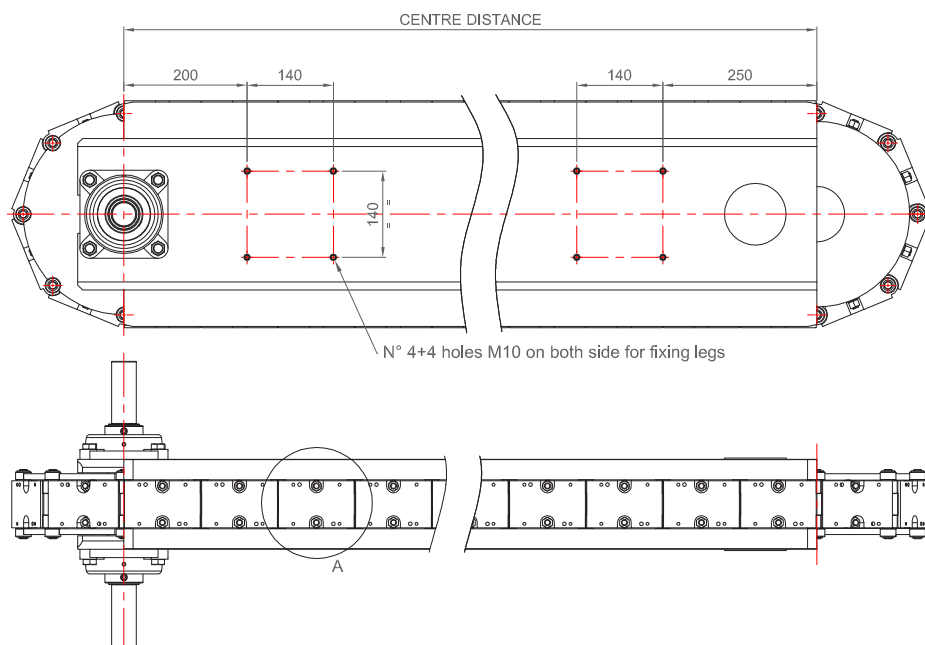
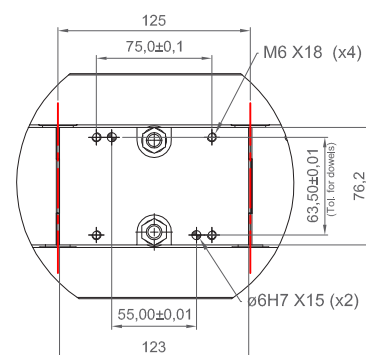

Available strokes	Center distance dimension	Denomination
31,25 - 62,5 - 125 - 250 - 375 - 500 - 625 - 750 - 875 - 1000 mm FLEXIBLE STROKES WITH SERVOMOTORS	500 mm to 11875 mm	PLC HA 125

PLC HA 150 mm

Link length: 150 mm

Centre distance: from 600 to 11850 mm

Load capacity:

- **Every dual pallets:** 150 kg
- **Every single pallet:** 75 kg

Overhung load capacity: 130 Nm

Length deviation: + 0,0120 mm/link

Accuracy:

- **X axis** ± 0,036 mm up to 600 mm +
± 0,007 m every 500 mm
- **Y axis** ± 0,040 mm
- **Z axis** ± 0,040 mm

Links tilts displacements:

- **X axis** ± 0,076 mm
- **Y axis** ± 0,040 mm
- **Z axis** ± 0,040 mm

Link overview

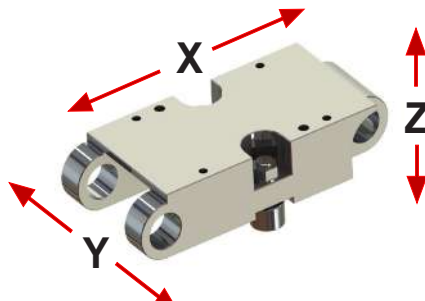

Optionals on request

- Globoidal Indexer as motorization
- Special Input shaft
- Customized pallets fixing holes
- High temperature pallet version
- Pendular mounting of the motorization
- Legs with X-Y-Z regulation
- Base frame

Dimensional evaluation: __mm* (page 31)

Additional features

- 6 pockets sprockets
- Structural steel beam with high rigidity
- High repeatability accuracy
- High overhung load capacity
- Over-Under / Carousel mounting options

VIEW FROM "A"

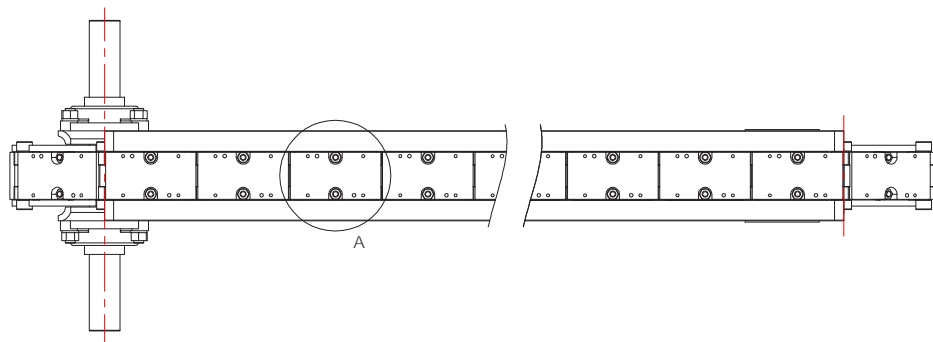
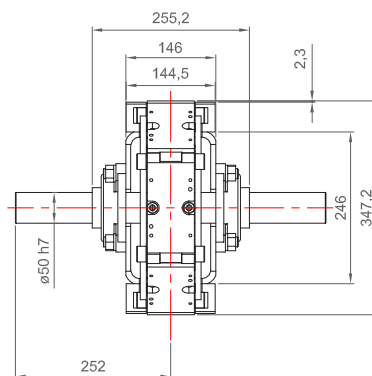
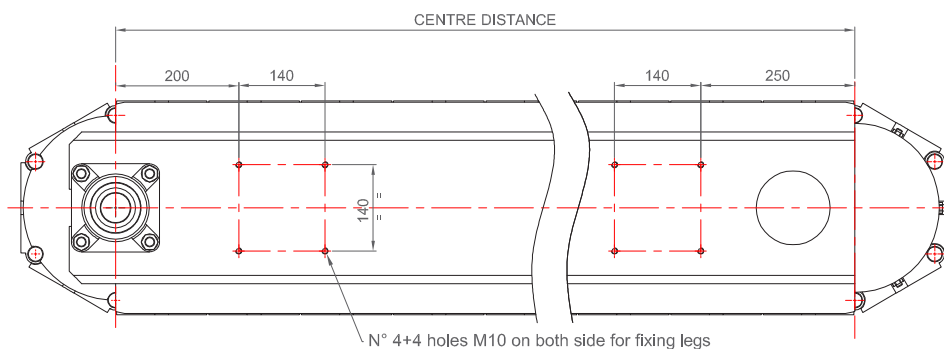
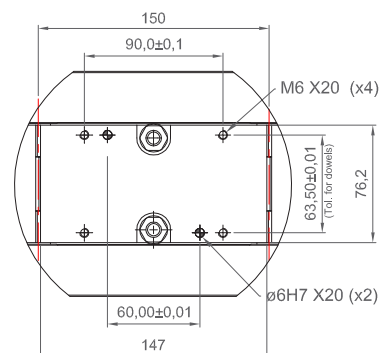

Available strokes	Center distance dimension	Denomination
37,5 - 75 - 150 - 300 - 450 - 600 - 750 - 900 mm FLEXIBLE STROKES WITH SERVO MOTOR	600 mm to 11850 mm	PLC HA 150

PLC HA 150 mm - XL Version

Link length: 150 mm

Centre distance: from 750 to 11850 mm

Load capacity:

- Every dual pallets: 150 kg
- Every single pallet: 75 kg

Overhung load capacity: 130 Nm

Length deviation: + 0,0120 mm/link

Accuracy:

- **X axis** $\pm 0,042$ mm up to 750 mm + $\pm 0,007$ mm every 500 mm
- **Y axis** $\pm 0,040$ mm
- **Z axis** $\pm 0,040$ mm

Links tilts displacements:

- **X axis** $\pm 0,076$ mm
- **Y axis** $\pm 0,040$ mm
- **Z axis** $\pm 0,040$ mm

Link overview

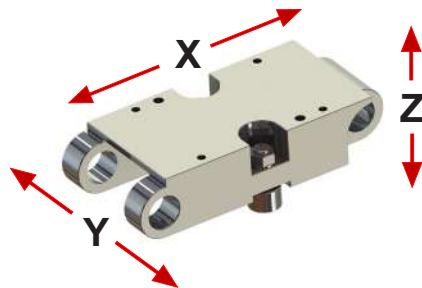

Dimensional evaluation: __mm* (page 31)

Additional features

- 12 pockets sprockets
- Structural steel beam with high rigidity
- High repeatability accuracy
- High overhung load capacity
- Over-Under / Carousel mounting options

Optionals on request

- Globoidal Indexer as motorization
- Special Input shaft
- Customized pallets fixing holes
- High temperature pallet version
- Pendular mounting of the motorization
- Legs with X-Y-Z regulation
- Base frame

VIEW FROM "A"

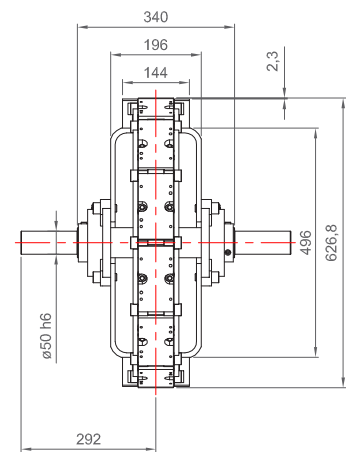
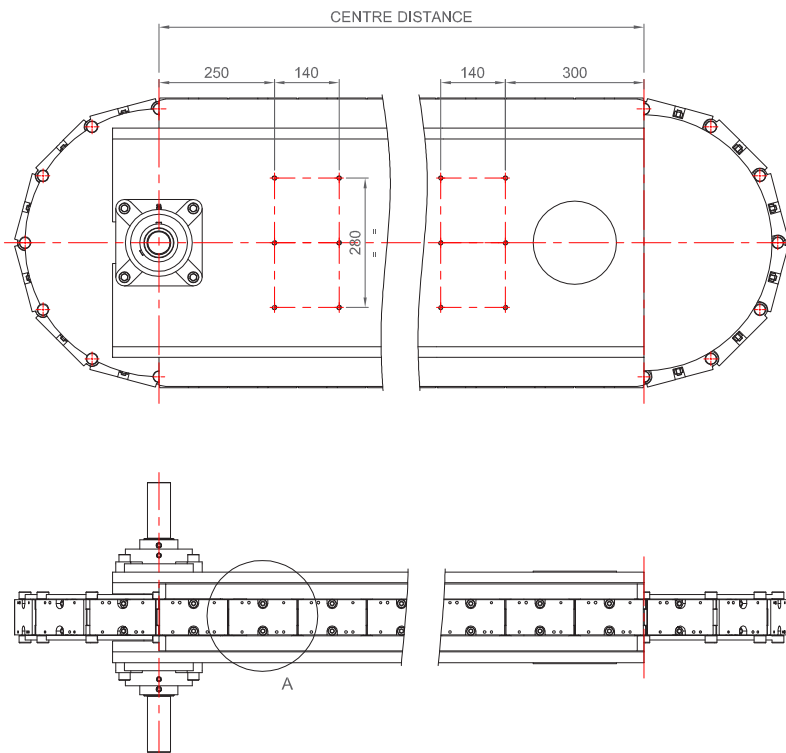
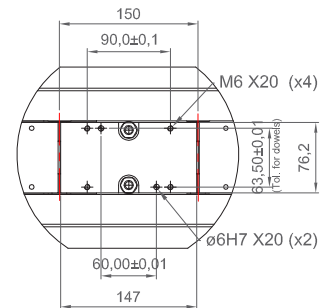

Available strokes	Center distance dimension	Denomination
37,5 · 75 · 150 · 300 · 450 · 600 · 750 · 900 · 1050 · 1200 · 1350 · 1500 · 1650 · 1800 mm FLEXIBLE STROKES WITH SERVOMOTORS	750 mm to 11850 mm	PLC HA 150 XL

PLC HA 250 mm

Link length: 250 mm
Centre distance: from 1000 to 11750 mm

Load capacity:

- **Every dual pallets:** 150 kg
- **Every single pallet:** 75 kg

Overhung load capacity: 180 Nm

Length deviation: + 0,0120 mm/link

Accuracy:

- **X axis** ± 0,045 mm up to 1000 mm + ± 0,007 mm every 500 mm
- **Y axis** ± 0,040 mm
- **Z axis** ± 0,040 mm

Links tilts displacements:

- **X axis** ± 0,076 mm
- **Y axis** ± 0,040 mm
- **Z axis** ± 0,040 mm

Link overview

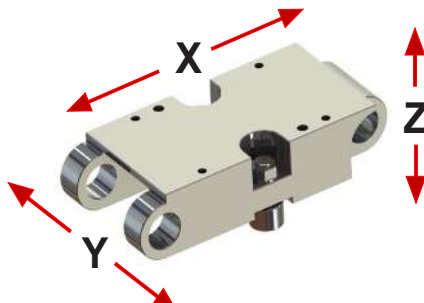

Dimensional evaluation: __mm* (page 31)

Additional features

- 8 pockets sprockets
- Structural steel beam with high rigidity
- High repeatability accuracy
- High overhung load capacity
- Over-Under / Carousel mounting options

Optionals on request

- Globoidal Indexer as motorization
- Special Input shaft
- Customized pallets fixing holes
- High temperature pallet version
- Pendular mounting of the motorization
- Legs with X-Y-Z regulation
- Base frame

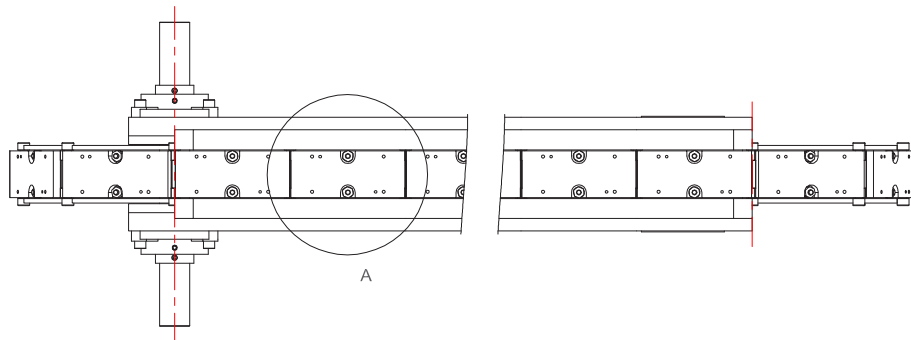
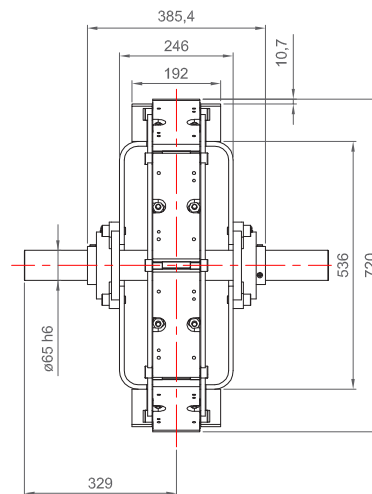
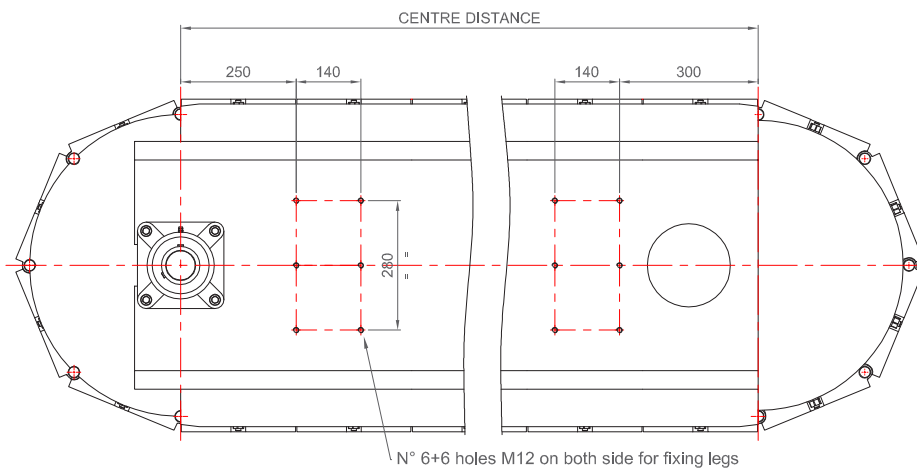
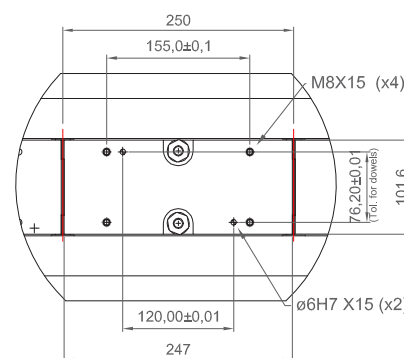

Available strokes	Center distance dimension	Denomination
62,5 - 125 - 250 - 500 - 750 - 1000 - 1250 - 1500 - 1750 - 2000 mm FLEXIBLE STROKES WITH SERVO MOTOR	1000 mm to 11750 mm	PLC HA 250

DATA SHEET

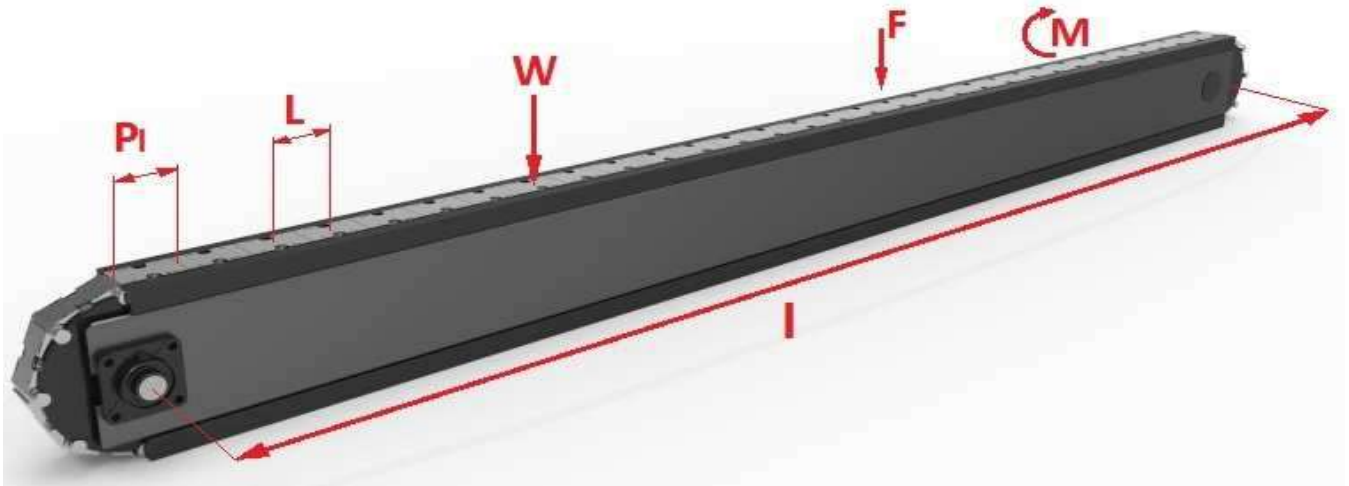

Conveyor model	
Center distance [mm / "]	I =
Linear stroke [mm / "]	L =
N° of stops	n =
Load for each pallet [kg]	W =
Additional forces [N]	F =
Additional moments [N]	M =
Mounting position	
Over Under	
Carousel	
Vertical	

Indexer	
or	
High Efficiency Reducer	
Continuous motion	Indexed motion (servo)
Cycle on Demand	
or	
Continuous running	
t. index [s]	ti =
t. dwell [s]	td =
t. cycle [s]	tc =
Frequency of cycle (Cam angle) [°]	Cyc/min =
	α =

Notes for the conveyor

Notes for the indexer

Name	Company	Rif.	
Address			
Email			

ITALPLANT IN THE WORLD

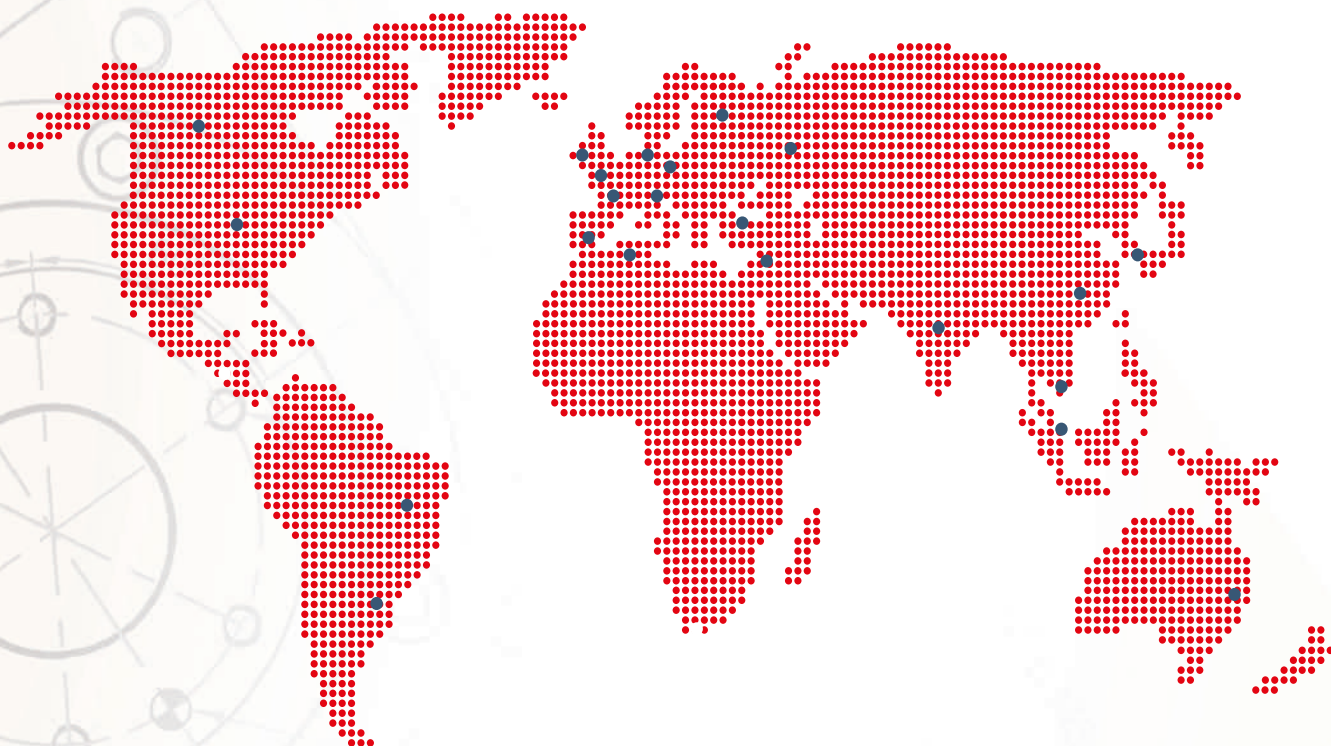

ITALPLANT

PRECISION TRANSFER SYSTEMS

Via Gonin, 45/A | 45/B - 10137 Torino (Italy)

Tel. +39 011 30 92 177

Email info@italplant.com

Distributor
Rivenditore



italplant.com