



**RNA**  
*We handle it.*



## COMPONENTS

### ***Vibratory Bowl Feeders***

- *Bowls*
- *Drive Units*
- *Control Boxes*
- *Accessories*



Reichsweg 19-23  
52068 Aachen  
Tel. Sales: +49 (0)241 / 51 09-0  
Fax Sales: +49 (0)241 / 51 09-219  
Email: [vertrieb@rna.de](mailto:vertrieb@rna.de)

**[www.RNA.de](http://www.RNA.de)**

## Welcome to RNA Germany – your market leader in the field of feeding technology!

Rhein-Nadel Automation GmbH is a traditional family-owned enterprise that has its head office in Aachen, Germany. With seven production locations and an international network of partners, we are there for you worldwide. For many decades now, our name has stood for top-class performance regarding technology, quality and reliability.

Our two business segments are the development and manufacture of complete custom-made feeding systems and their corresponding components.

With many years experience in the automation and parts handling industry and nearly 2000 complete feeding systems supplied annually, RNA has earned a reputation for the most robust and reliable equipment on the market. Our commitment to research and development maintains our position at the leading edge of feeding technology. We provide an extensive range of the most efficient drive units, controllers and accessories for either standard or special requirements. All equipment is manufactured to the highest standards of quality upon which we have built our reputation. We offer first class service and standard equipment, immediate delivery from stock. Our product range is manufactured to meet the highest demands of the food and pharmaceutical industries and also includes equipment manufactured to UL and CSA standards. Quality has always been of central importance to RNA, with each employee committed to make their own personal contribution to the achievement of quality standards and customer satisfaction. We know that long term success in business can only be achieved by providing high quality equipment, which fulfils the customer's requirements.



# Vibratory Bowl Feeders from RNA

The catalogue represents our complete range of standard equipment for vibratory bowl feeders, which is available from stock. It includes drive units, bowls, bowl centres, control boxes and additional accessories including stands, base plates, sound covers and sensors. Special requirements are available upon request. We also manufacture tooling to orientate components, which together with our standard equipment, provides a system ready to integrate with a customer's machine.

This catalogue is addressed to customers, who take direct control of the orientation devices.

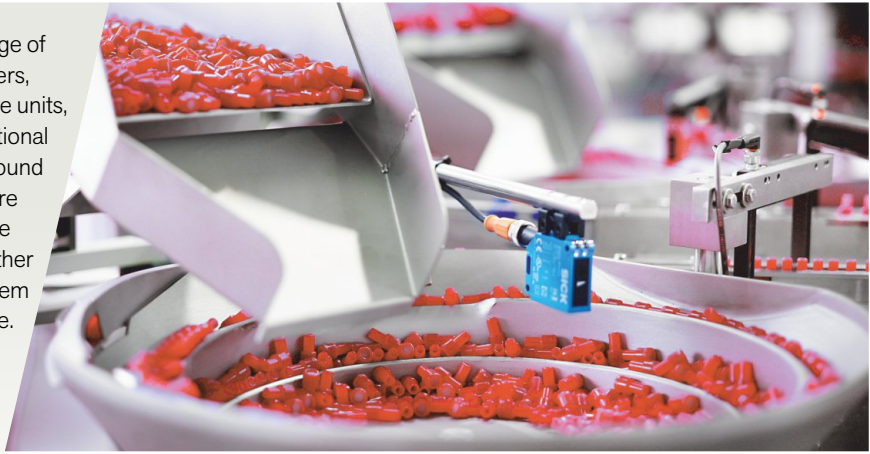

## Table of contents

Subject	see page:
RNA - the company	page 02
Equipment catalogue	page 03
How to use the catalogue	page 04
Bowls <span style="background-color: red; color: white; padding: 0 2px;">1</span>	page 06
Bowl centres <span style="background-color: red; color: white; padding: 0 2px;">2</span>	page 13
Bowl coatings	page 14
Level controller	page 15
Drive units <span style="background-color: red; color: white; padding: 0 2px;">3</span>	page 16
Control boxes <span style="background-color: red; color: white; padding: 0 2px;">4</span> Soundcovers <span style="background-color: red; color: white; padding: 0 2px;">5</span>	page 19
Base plates <span style="background-color: red; color: white; padding: 0 2px;">6</span>	page 20
Top plates <span style="background-color: red; color: white; padding: 0 2px;">7</span> and stands <span style="background-color: red; color: white; padding: 0 2px;">8</span>	page 21
Product overview and reference codes	page 22

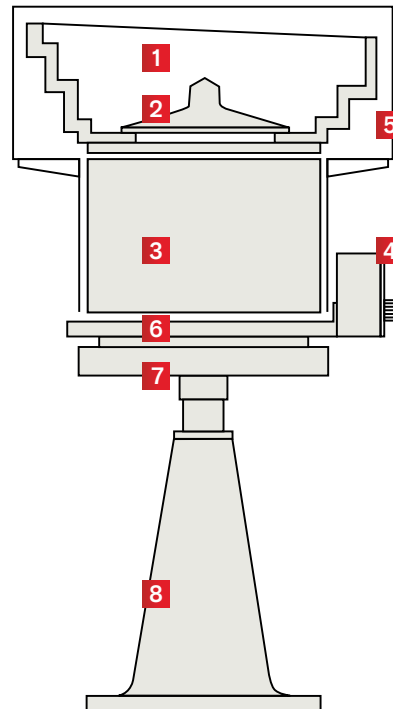

Please refer to instructions on the following pages. A summary table for all standard equipment, showing all equipment and the construction sizes, you will find on page 22 and 23 or at [www.rnaautomation.com](http://www.rnaautomation.com) and [www.rna.de](http://www.rna.de)

## More product catalogues from the RNA range of equipment

Conveyors	
Linear feeders	
Bowl feeders	
Control boxes	
Bulk hoppers	
Step feeders (not shown to the right)	

Colours of catalogues

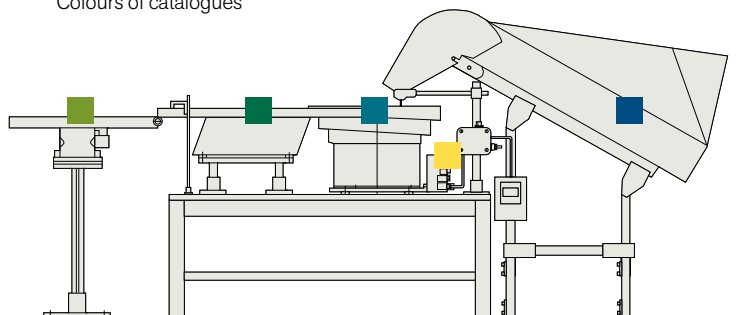

## How to use this catalogue

1.

### Selection of bowl type

(cylindrical, conical, stepped)  
according to the table given below.

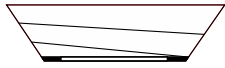
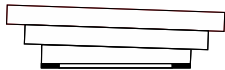
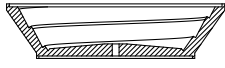

Technical data is subject to change. All measurements are stated in mm.

▶▶▶ Bowl	Type & suitable for	page
	<b>Cylindrical bowls:</b> continuous transport of components and for handling small parts	page 06
	<b>Conical bowls:</b> heavy sharp-edged components, larger loads, automatic pre-separating  <b>Type RG:</b> ideal for the food and pharmaceutical industry	page 08  page 08
	<b>Stepped bowls:</b> larger loads and larger components, see also conical bowls	page 10
	<b>Polyamide bowls (conical or stepped):</b> small components with simple geometry and where mass production of feeders is required	page 12

<b>Bowl type</b> Z = cylindrical K = conical T = stepped	<b>Material</b> A = Aluminium S = Stainless Steel K = Polyamide	<b>Size</b>	<b>Width of track (mm)</b> X = variable	<b>bowl height</b> from the screwing on point
---	--	-------------	--	---

▶▶▶ RNA-Code for bowls:

**K S B - Z A - 2 5 0 - 8 ( R G ) - 1 5 0**

**Design**  
B = steel metal construction  
D = turned  
F = machined  
G = cast

**Centres/different fixings**  
N = nothing, additional centres required  
Z = welded bottom with centre fixing  
B = welded bottom only,  
A = adapter plate  
2A = additional adapter plate for centre fixing

**Track type**  
R = rectangular,  
G = closed



## 2.

### Definition of the size:

Dependent upon the application, you can define the bowl size by choosing the track width measurement (B).

Each bowl has a dedicated drive unit.  
For ease of machine assembly we recommend the use of a base plate.



Please use the code for enquiries and orders.

Type	ZSD-Z 160-12-70	ZSB-Z 160-12-70	ZSB-Z 200-12-80			
▶ Capacity [l]*	0,5	0,5	0,8			
Material	Steel	Stainless Steel	Stainless Steel			
A = Discharge height	64	64	65			
▶ B = Width of track	12	12	12			
D = Bowl diameter	168	168	181			
H = Height of bowl	70	70	80			
S = Track pitch (Spiral distance)	22	22	22			
Bowl weight [kg]	1,4	1,1	1,35			
Fixing	central	central	central			
Bottom (see page 13)	integral	fully welded	fully welded			
▶ Suitable drive unit (see also page 16)	SRC-N 160	SRC-N 160	SRC-N 200			
Z = Total discharge height	220 (SRC-SRG) 237 (SRC-USJ)	220 (SRC-SRG) 237 (SRC-USJ)	253 (SRC-SRG) 275 (SRC-USJ)			
▶ Suitable base plate (see also page 19)	SRG-N 160 USJ 160	SRG-N 160 USJ 160	SRG-N 200 USJ 200			

## 3.

Please state the feed direction for orders of bowls and drive units. ▶▶

- 1) Left handed: anti-[counter-]clockwise
- 2) Right handed: clockwise

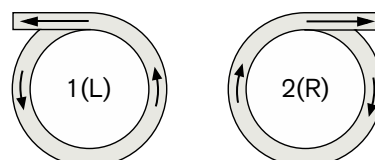

## Cylindrical Bowls

These bowls provide a constant feed of components. They are ideal for small components, but have restricted capacity for some applications.



Type	ZAD-Z 63-4-18	ZAD-Z 100-6-50	ZSD-Z 160-12-70	ZSB-Z 160-12-70	ZSB-Z 200-12-80	ZSB-N 250-30-110
Capacity [l]*	0,05	0,2	0,5	0,5	0,8	1,6
Material	Aluminium	Aluminium	Steel	Stainless Steel	Stainless Steel	Stainless Steel
A = Discharge height	17	35	64	64	65	100
B = Width of track	5	6	12	12	12	30
D = Bowl diameter	70	100	168	168	181	288
H = Height of bowl	18	40	70	70	80	110
S = Track pitch (Spiral distance)	8	12	22	22	22	35
Bowl weight [kg]	0,09	0,3	1,4	1,1	1,35	4,2
Fixing	central	central	central	central	central	radial
Bottom (see page 13)	integral	integral	integral	fully welded	fully welded	required
Suitable drive unit (see also page 16)	SRC-N 63	SRC-N 100	SRC-N 160	SRC-N 160	SRC-N 200	SRC-N 250
Z = Total discharge height	82	117	220 (SRC-SRG) 237 (SRC-USJ)	220 (SRC-SRG) 237 (SRC-USJ)	253 (SRC-SRG) 275 (SRC-USJ)	350 (SRC-SRG) 368 (SRC-USJ)
Suitable base plate (see also page 19)	-	-	SRG-N 160 USJ 160	SRG-N 160 USJ 160	SRG-N 200 USJ 200	SRG-N 250 USJ 250

\* Larger capacities available, dependent on application and components

The measurements mentioned above are valid for standard equipment without tooled devices.  
Subject to manufacturing tolerances.

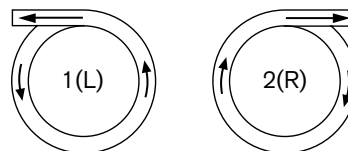
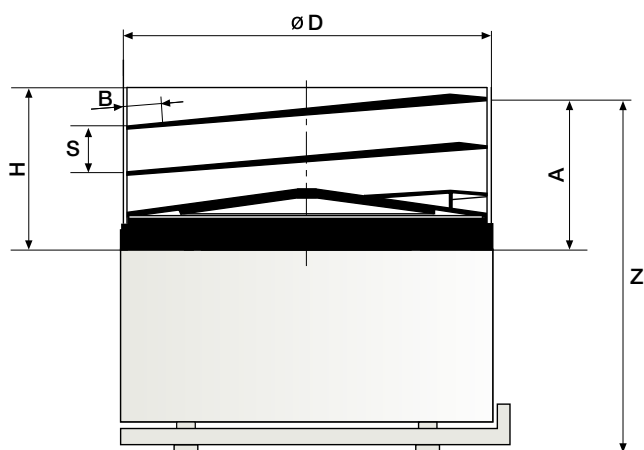

Please advise feed direction when ordering (see also page 5).

	ZSB-ZA 250-30-125	ZSB-N 400-30-160	ZSB-BA 400-30-175	ZSB-Z2A 400-30-190	ZSB-N 630-50-180	ZSB-BA 630-50-195	ZSB-B 800-80-220
	1,6	7	7	7	20	20	20
	Stainless Steel	Stainless Steel	Stainless Steel	Stainless Steel	Stainless Steel	Stainless Steel	Stainless Steel
	120	140	155	171	156	167	195
	30	30	30	30	50	50	80
	288	440	440	440	670	670	820
	127	160	175	191	180	195	220
	33**	50	50	50	70	70	70
	6,4	8,4	10,6	16,3	16,2	18,7	36,8
	central	radial	radial	central	radial	radial	radial
	fully welded	required	fully welded	fully welded	required	fully welded	fully welded
	SRC-N 250	SRC-N 400 SRHL 400	SRC-N 400 SRHL 400	SRC-N 400 SRHL 400	SRC-N 630	SRC-N 630	SRC-N 800
	370 (SRC-SRG) 388 (SRC-USJ)	403 (SRC-SRG) 421 (SRC-USJ) 427 (SRHL-SRG) 445 (SRHL-USJ)	418 (SRC-SRG) 436 (SRC-USJ) 442 (SRHL-SRG) 460 (SRHL-USJ)	434 (SRC-SRG) 452 (SRC-USJ) 458 (SRHL-SRG) 476 (SRHL-USJ)	419 (SRC-SRG) 444 (SRC-USJ)	430 (SRC-SRG) 455 (SRC-USJ)	510
	SRG-N 250 USJ 250	SRG-N 400 USJ 400	SRG-N 400 USJ 400	SRG-N 400 USJ 400	SRG-N 630 USJ 630	SRG-N 630 USJ 630	- -

\*\* Each track pitch increased by 3mm

## Conical Bowls

A conical bowl provides a higher capacity and with an increase in radius, assists the pre-separation of components. Where necessary, the standard track width, track pitch and the amount of tracks can be adapted to suit the application.

Type RG makes pre-orientation possible through a sloping track position, which prevents parts jamming between the pitch of the tracks. The closed track type is particularly suitable for pharmaceutical applications.



Type	KAD-Z 63-4-30	KAD-Z 100-4-40	KSB-Z 200-18-55	KSB-N 250-20-90	KSB-ZA 250-20-105
RG Range			KSB-Z 200-5RG-60		
Capacity [l]*	0,04	0,15	0,5	2	2
Material	Aluminium	Aluminium	Stainless Steel	Stainless Steel	Stainless Steel
A = Track discharge height RG Range	25	35	47 50	77	110
B = Discharge height RG Range	4	4	18 5	20	20
D = Bowl diameter RG Range	69	99	265 277	403	415
H = Bowl height RG Range	30	40	55 58	89	113
S = Track pitch (Spiral distance) RG Range	6,5	11	25 28	32	32
Bowl weight [kg]	0,11	0,34	1,46 1,70	3,85	8,2
Fixing	central	central	central	radial	central
Bottom (see page 13)	integral	integral	fully welded	required	fully welded
Suitable drive unit (see page S. 16)	SRC-N 63	SRC-N 100	SRC-N 200	SRC-N 250	SRC-N 250
Z = Total discharge height	90	117	235 (SRC-SRG) 257 (SRC-USJ)	327 (SRC-SRG) 345 (SRC-USJ)	360 (SRC-SRG) 378 (SRC-USJ)
RG Range			238 (SRC-SRG) 260 (SRC-USJ)		
Suitable base plate (see page 20)			SRG-N 200 USJ 200	SRG-N 250 USJ 250	SRG-N 250 USJ 250

\* Larger capacities available, dependent on application and components



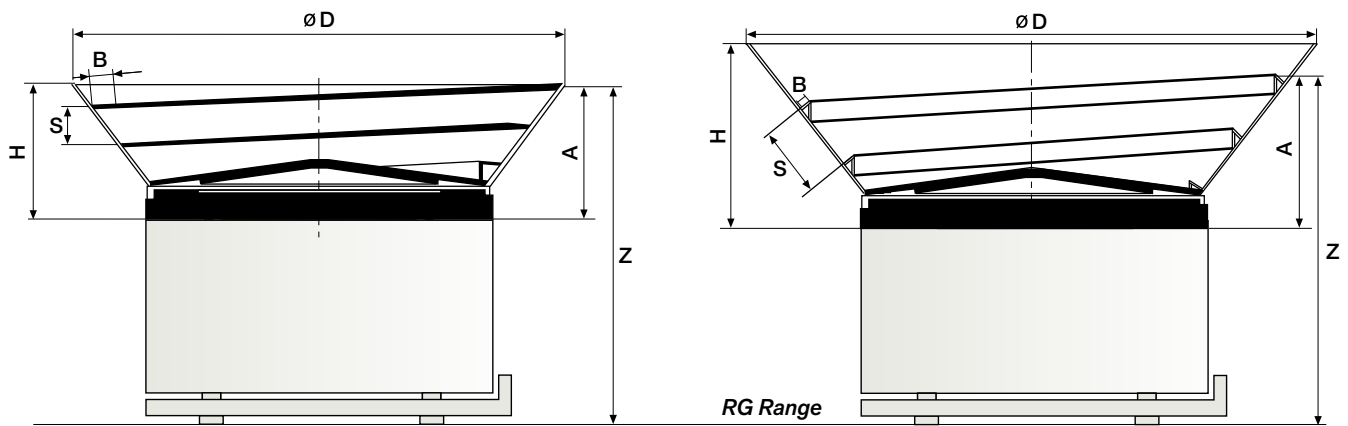

	<b>KSB-ZA 250-20-150</b>	<b>KSB-N 400-50-160</b>	<b>KSB-BA 400-50-175</b>	<b>KSB-Z2A 400-50-190</b>	<b>KSB-N 630-50-180</b>	<b>KSB-BA 630-50-190</b>	<b>KSB-B 800-80-170</b>
	<b>KSB-ZA 250-8RG-150</b>		<b>KSB-BA 400-15RG-220</b>	<b>KSB-Z2A 400-15RG-235</b>		<b>KSB-BA 630-15RG-250</b>	
	2	10	10	10	20	20	25
	Stainless Steel	Stainless Steel	Stainless Steel	Stainless Steel	Stainless Steel	Stainless Steel	Stainless Steel
	136 138	153	164 169	180 185	172	167 149	148
	20 8	50	50 15	50 15	50	50 15	80
	476 478	670	670 745	670 745	898	898 980	1200
	151 151	161	173 220	189 236	180	192 250	168
	32 40	68	68 71	68 71	70	70 81	64
	9,2 10,8	12,9	13,6 16	19,4 23,2	19	21,5 27	35
	central	radial	radial	central	radial	radial	radial
	fully welded	required	fully welded	fully welded	required	fully welded	fully welded
	SRC-N 250	SRC-N 400 SRHL 400	SRC-N 400 SRHL 400	SRC-N 400 SRHL 400	SRC-N 630	SRC-N 630	SRC-N 800
	386 (SRC-SRG) 404 (SRC-USJ)	416 (SRC-SRG) 434 (SRC-USJ) 440 (SRHL-SRG) 458 (SRHL-USJ)	427 (SRC-SRG) 445 (SRC-USJ) 451 (SRHL-SRG) 469 (SRHL-USJ)	443 (SRC-SRG) 461 (SRC-USJ) 467 (SRHL-SRG) 485 (SRHL-USJ)	435 (SRC-SRG) 460 (SRC-USJ)	430 (SRC-SRG) 455 (SRC-USJ)	463
	388 (SRC-SRG) 406 (SRC-USJ)		432 (SRC-SRG) 450 (SRC-USJ) 456 (SRHL-SRG) 474 (SRHL-USJ)	448 (SRC-SRG) 466 (SRC-USJ) 472 (SRHL-SRG) 490 (SRHL-USJ)		412 (SRC-SRG) 437 (SRC-USJ)	
	SRG-N 250 USJ 250	SRG-N 400 USJ 400	SRG-N 400 USJ 400	SRG-N 400 USJ 400	SRG-N 630 USJ 630	SRG-N 630 USJ 630	

Please advise feed direction when ordering (see also page 5).

The measurements mentioned above are valid for standard equipment without tooled devices.

Subject to manufacturing tolerances.

## Stepped Bowls

Stepped bowls have a larger feeding track width and are particularly suited to pre-orientate components. The capacity is larger than that of a cylindrical bowl. A further advantage is that the components do not jam in the tracks. All stepped bowls are cast aluminium, which need to be coated (see also page 14, coating).

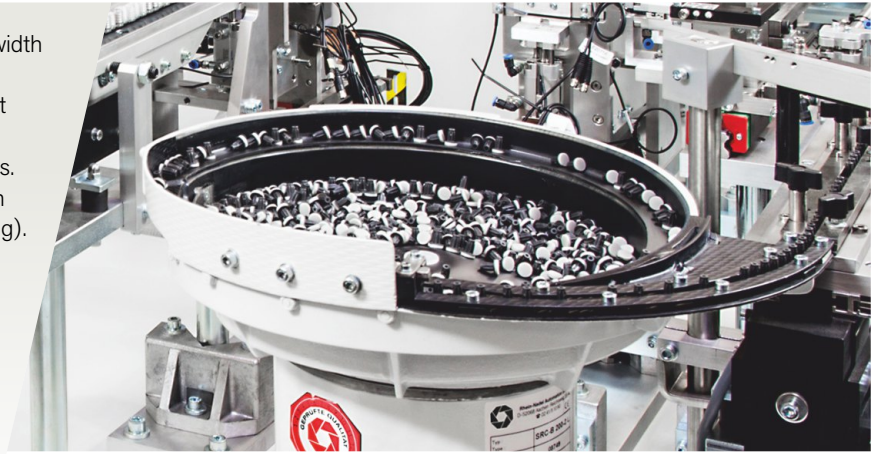

Please advise feed direction when ordering (see also page 5).

Type	TAG-Z 200-10-80	TAG-Z 200 (324)-20-105	TAG-N 250-20-105	TAG-N 250-32-130	TAG-N 250-32-145	TAG-ZA 250-32-165	TAG-ZA 250 (541)-32-180
Capacity [l]*	0,5	1	1	2	2	2	7
Material	Aluminium	Aluminium	Aluminium	Aluminium	Aluminium	Aluminium	Aluminium
A = Discharge height	66	71	77	90	107	126	135
B = Width of track	10	20	20	32	32	32	32
C = Discharge radius	115	166	168	206	206	206	275
D = Bowl diameter	228	330	330	400	400	400	545
H = Bowl height	81	95	102	122	140	160	177
S = Track pitch (Spiral distance)	20	32	34	42	42+15**	42+15**	50+15**
Bowl weight [kg]	0,8	2,6	1,65	2,9	3,4	6,9	8,2
Fixing	central	central	radial	radial	radial	central	central
Bottom (see page 13)	cast	cast	required	required	required	cast	cast
Suitable drive unit (see page.16)	SRC-N 200	SRC-B 200	SRC-N 250	SRC-N 250	SRC-N 250	SRC-N 250	SRC-B 250
Z = Total discharge height	254 (SRC-SRG) 271 (SRC-USJ)	259 (SRC-SRG) 281 (SRC-USJ)	327 (SRC-SRG) 345 (SRC-USJ)	340 (SRC-SRG) 358 (SRC-USJ)	357 (SRC-SRG) 375 (SRC-USJ)	376 (SRC-SRG) 394 (SRC-USJ)	385 (SRC-SRG) 403 (SRC-USJ)
Suitable base plate (see page 20)	SRG-N 200 USJ 200	SRG-N 200 USJ 200	SRG-N 250 USJ 250	SRG-N 250 USJ 250	SRG-N 250 USJ 250	SRG-N 250 USJ 250	SRG-N 250 USJ 250

\* Larger capacities available, dependent on application and components

\*\* Additional gradient on last 180 degrees

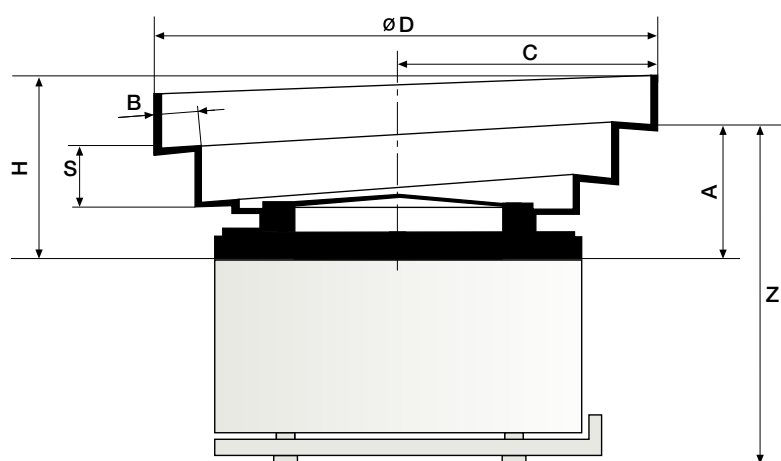

Please advise feed direction when ordering (see also page 5).

	TAG-N 400-32-165	TAG-N 400-50-190	TAG-N 400-50-215	TAG-ZA 400-50-240	TAG-N 630-50-220	TAG-N 630-65-230	TAG-ZAB 630-50-240	TAG-ZAB 630-65-250
	7	10	10	10	25	25	25	25
	Aluminium	Aluminium	Aluminium	Aluminium	Aluminium	Aluminium	Aluminium	Aluminium
	124	138	162	188	157	157	197	197
	32	50	50	50	50	65	50	65
	275	335	335	335	440	440	440	440
	545	645	645	650	830	830	830	830
	165	190	215	241	222	230	242	250
	50+15**	68	68+23**	68+23**	76	95	76	95
	5	9	11,7	14,7	18	18	27	27
	radial	radial	radial	central	radial	radial	central	central
	required	required	required	cast	required	required	screwed in	screwed in
	SRC-N 400	SRC-N 400	SRC-N 400	SRC-N 400	SRC-N 630	SRC-N 630	SRC-N 630	SRC-N 630
	387 (SRC-SRG) 405 (SRC-USJ) 411 (SRHL-SRG) 429 (SRHL-USJ)	401 (SRC-SRG) 419 (SRC-USJ) 425 (SRHL-SRG) 443 (SRHL-USJ)	425 (SRC-SRG) 443 (SRC-USJ) 449 (SRHL-SRG) 467 (SRHL-USJ)	451 (SRC-SRG) 469 (SRC-USJ) 475 (SRHL-SRG) 493 (SRHL-USJ)	420 (SRC-SRG) 445 (SRC-USJ)	420 (SRC-SRG) 445 (SRC-USJ)	460 (SRC-SRG) 485 (SRC-USJ)	460 (SRC-SRG) 485 (SRC-USJ)
	SRG-N 400 USJ 400	SRG-N 400 USJ 400	SRG-N 400 USJ 400	SRG-N 400 USJ 400	SRG-N 630 USJ 630	SRG-N 630 USJ 630	SRG-N 630 USJ 630	SRG-N 630 USJ 630

The measurements mentioned above are valid for standard equipment without tooled devices.  
Subject to manufacturing tolerances.

## Polyamide Bowls

Plastic bowls show favourable sliding and running properties: an unfavourable mating of steel on steel is avoided. Customized milling of the bowl and spiral makes it flexible to shape and reproduce the plastic bowl. The sound pressure level is reduced. Plastic bowls are available in a stepped shape (TKF) or in a conical shape (KKF).

Individual measures and shapes upon request.  
A multithread design is possible upon request.

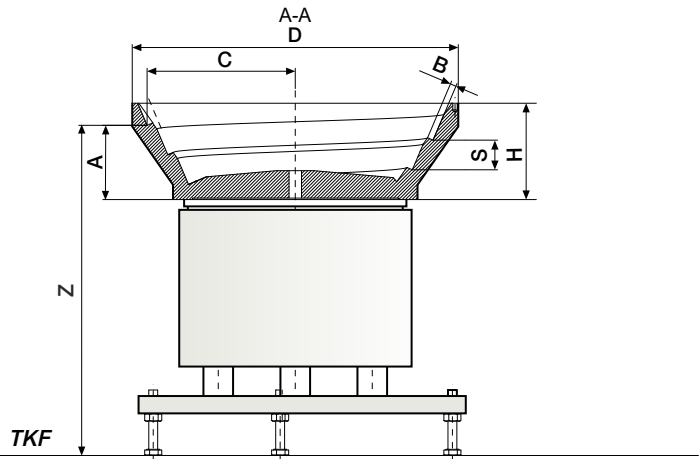

Please advise feed direction when ordering (see also page 5).

Type	KKF-Z 100-X-40	TKF-Z 100-X-40	KKF-Z 160-X-65	TKF-Z 160-X-65	KKF-Z 200-X-65	TKF-Z 200-X-65	KKF-ZA 250-X-100	TKF-ZA 250-X-100
Capacity [l]**	0,2	0,2	1,2	1,2	1,2	1,2	6	5
Material****	PA 6-G black	PA 6-G black	PA 6-G black	PA 6-G black	PA 6-G black	PA 6-G black	PA 6-G black	PA 6-G black
A = Discharge height**	33-32	33-32	51-50	50-48	51-50	50-48	85-83	88-87
B = Width of track	1-4	1-5	1-4	1-9	1-4	1-9	1-7	1-10
C = Discharge radius**	50-53	53-57	97-100	99-108	97-100	99-107	175-180	176-186
D = Bowl diameter	120	120	220	230	220	230	400	400
H = Bowl height	40	40	65	65	65	65	100	100
S = Track pitch* (Spiral distance)	12	12	20	20	20	20	36	36
Fixing	central	central	central	central	central	central	central	central
Suitable drive unit (see page 16)	SRC-N 100	SRC-N 100	SRC-N 160	SRC-N 160	SRC-N 200	SRC-N 200	SRC-N 250	SRC-N 250
Z = Total discharge height** inkl. „USJ“/regulating range ±10 mm (100 series without USJ)	115-114	115-114	223-222	223-221	256-255	255-253	372-370	376-375

\* measured vertically

\*\* varies depending on the track width

\*\*\* approximate indication; a larger filling volume is possible depending on the nature of the task and workpiece

\*\*\*\* alternative material possible

### Structural shape:

KKF= conical shape

TKF= stepped shape (stepped design)

Moving direction to the left and right and multiple-current designs are possible

Alternative designs are possible

The measurements mentioned above are valid for standard equipment without tooled devices.  
Subject to manufacturing tolerances.

## Centres

If there is an aperture in the bottom of the bowl, either a rotating or fixed centre is required.

Material type:

PA = Polyamide

AL = Aluminium

VA = Stainless steel

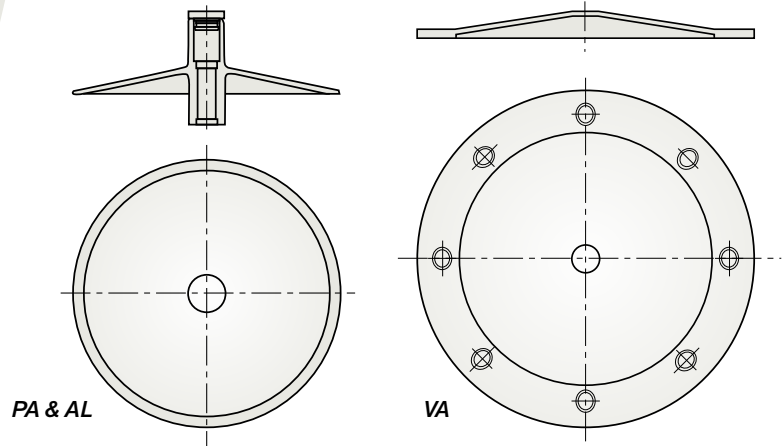

### Loose/rotating centres (non vibrating)

Size	SRL-N 250		SRL-N 400		SRL-N 630
Material	PA	AL	PA	AL	AL

**Loose/rotating centres (SRL) are used in the following circumstances:**

1. To relieve pressure on the bowl drive unit
2. Keeping vibration of components to a minimum
3. To reduce noise levels

**Please note:**

Certain products can get trapped between the rotating centre and base of the bowl and small quantities of parts may be left within the feeder. For heavy parts we recommend the use of an aluminium rotating centre (SRL AL).

### Fixed centres (vibrating)

Size	SRF-N 250			SRF-N 400			SRF-N 630	
Material	PA	AL	VA	PA	AL	VA	AL	VA

**Fixed centres (SRF) provide the following advantages:**

1. There are no gaps to trap parts
2. The centre will not allow dust or debris into the drive unit
3. The bowl can be purged of components

## Selection of basic material

### Stainless steel centres (only for fixed centres)

Suitable when a hopper feeds components into the same position on the centre at the bottom of the bowl. Will provide more durability.

### Polyamide or aluminium centres (PA or AL)

The choice of the material is dependent upon the weight and condition of components.



## Coatings

Coating minimises wear and tear and reduces noise and damage to components. Coatings can be selected according to the application.

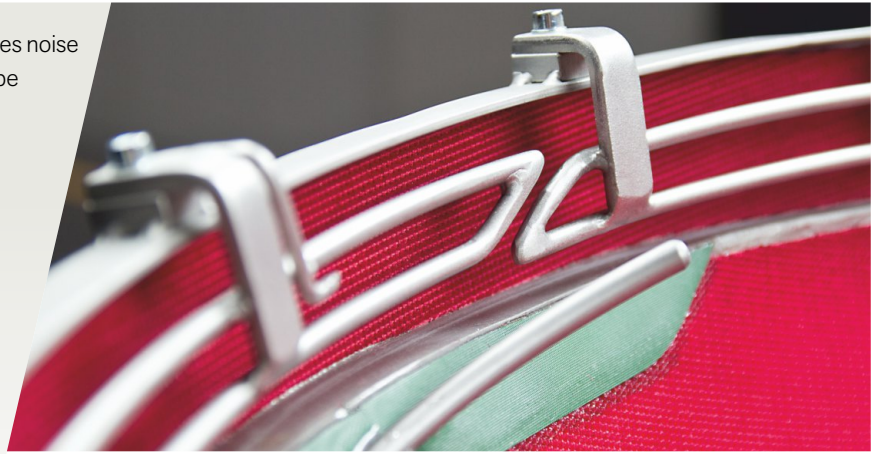

Coating Material	Characteristics	Application
<b>Polyurethane spray coating</b> colour: beige	<ul style="list-style-type: none"> <li>· smooth surface</li> </ul>	rubber and plastic parts
<b>Polyurethane lining</b> 1 mm thickness colour: black	<ul style="list-style-type: none"> <li>· high durability, good sound reduction and can be applied either side i.e. smooth or rough side can be used as track surface. Rough surface is suitable for wet parts</li> </ul>	dry and clean metal parts and heavy plastic parts
<b>Polyurethane lining</b> 2 mm thickness colour: black	<ul style="list-style-type: none"> <li>· as above plus:</li> <li>· very hard wearing,</li> <li>· abrasion resistant,</li> <li>· shock proof and very good sound reduction</li> </ul>	as above plus: heavy sharp metal, glass and abrasive parts e.g. screws, forged and pressed parts
<b>Polyurethane lining ribbed</b> colour: black	<ul style="list-style-type: none"> <li>· allows oil dispersal through ribs</li> </ul>	oily, wet and sticky parts (pressings and stampings)
<b>Habasit lining (HAM-5P)</b> colour: green  <b>suitable for food</b> colour: white	<ul style="list-style-type: none"> <li>· high feed rates for wet/oily parts</li> <li>· reduces static on plastic parts</li> <li>· side wall coated with polyurethane foil (1 mm)</li> </ul>	Parts with smooth surfaces, light plastic parts and light oily parts (pull-in oil, separating agent)
<b>Brush coating</b>	<ul style="list-style-type: none"> <li>· feeding of oily parts, gentle/careful feeding, noise reduction</li> </ul>	blank screws, heavy metal parts, parts with delicate surfaces
<b>Flock lining</b> textile surface	<ul style="list-style-type: none"> <li>· gentle parts feeding</li> <li>· improved feed rates</li> </ul>	light parts with delicate surfaces prone to marking
<b>Metaline</b>	<ul style="list-style-type: none"> <li>· wear-resistant surfaces overlaid joints</li> <li>· adjustable hardness and surfaces</li> <li>· different colours possible</li> </ul>	light to mid-heavy plastic and metal parts with dry surfaces, Pharma: FDA-certification available

## Level Controller

Our level control type EFP stands out for its compact and insensitive construction. Furthermore, the level controller can be directly connected to relays, control boxes etc. and does not have to be seized between pendulum and track.

The level controllers are used for automatic control of the filling volume for mass-produced parts in bowl feeders, hoppers etc.

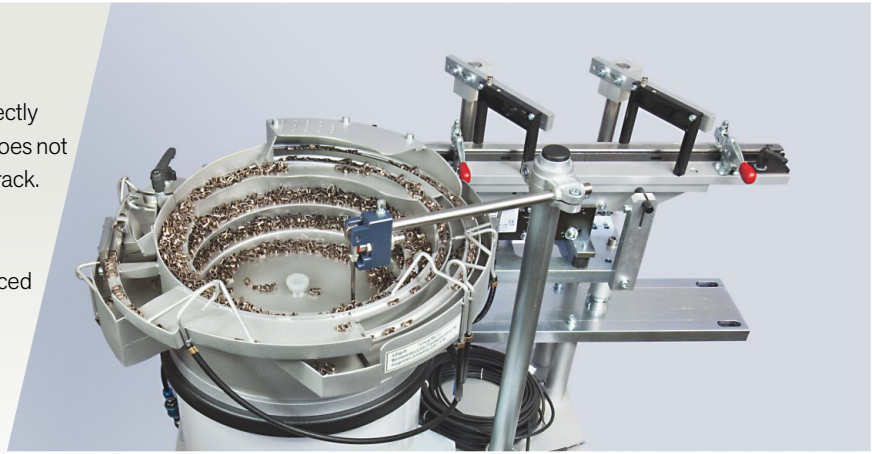

### Type

EFP24-12

Inductive sensor (for transformation of the mechanical motion of the penulum in an electrical signal)	Ø 12 mm
Operating voltage (optional)	10 – 30 VDC or 90 – 250 VAC
Max. capacity of the sensor	130mA or 200mA
Protection	IP 67
Total cable length from the sensor	1.500 mm
Execution pendulum	Bowl or paddle
Displacement pendulum	0° - 45 °



### Standard design

The level control will be supplied with pendulum, sensor (optional 24VDC) and holder (guide tube/Ø14mm).

### Accessory

A support stand (support: height approx.. 600 mm) for mounting on a machine table can be offered.

The EFP24-12 can be also fitted with a 5-pol. connector plug at an RNA sensor amplifier (ESK 2000, ESK 2001, ESR 2000 and ESR 2500).

## Drive Units (-2 design)

RNA drive units offer reliability and endurance. The use of high performance magnets give a continuous high feed rate regardless of the number of parts in the bowl. RNA drive units are renowned for their durability, smooth feed characteristics and low noise levels.

Application area for 100 Hz vibration frequency

- if "fine" orienting devices are needed for small sort criterions of the work pieces
- better for critical cutting site passage (small vibrating cast of the work pieces)



**Please advise feed direction when ordering** (see also page 5).

Subject to manufacturing tolerances.

Type	SRC-N 63-2	SRC-N 100-2	SRC-N 160-2	SRC-N 200-2	SRC-B 200-2**	SRC-N 250-2
<b>h</b> = Drive unit height/Top casting	65	82	132	165	165	218
<b>J</b> = Drive unit diameter	60	90	157	180	180	290
<b>K</b> = Pitch between mountings/no. of bores	40/2	70/3	120/3	130/3	130/3	220/3
<b>L</b> = Thread dimensions	M4	M4	M6	M6	M6	M8
<b>M</b> = Bowl fixing	M5	M5	M8	M8	M8	M6 8x45°
<b>N</b> = Shoulder diameter	-	-	150	161	161	165
<b>G</b> = Bolt circle (Bowl fastening)	-	-	-	-	-	186
Drive unit weight [kg]	0,8	1,8	7	11	11	40
Rating in amps [A]	0,04	0,055	0,55	1,2	1,2	2,6
Length of connection cable* [m]	1,4	1,4	1,4	1,4	1,4	2,5
Vibration frequency	100 Hz 6000 min	100 Hz 6000 min	100 Hz 6000 min	100 Hz 6000 min	100 Hz 6000 min	100 Hz 6000 min
Nominal voltages (available on request with 220V)	230V 50-60Hz 110V 50-60Hz	230V 50-60Hz 110V 50-60Hz	200V 50Hz 200V 60Hz 110V 50Hz 110V 60Hz	200V 50Hz 200V 60Hz 110V 50Hz 110V 60Hz	200V 50Hz 200V 60Hz 110V 50Hz 110V 60Hz	200V 50Hz 200V 60Hz 110V 50Hz 110V 60Hz
Execution standard	CE	CE	CE, CSA/UL	CE, CSA/UL	CE	CE, CSA/UL
Protective casing	IP54	IP54	IP54	IP54	IP54	IP54
Protective casing (special painting on request)	Steel, painted RAL7035 light grey	Steel, painted RAL7035 light grey	Steel, painted RAL7035 light grey	Steel, painted RAL7035 light grey	Steel, painted RAL7035 light grey	Steel, painted RAL7035 light grey

\* Longer connection cables are available upon request

\*\* Extra springs for larger bowl capacity

**We are also manufacturing RNA bowl drives according to your specification, as for example:**

- extra springs
- cover with special paint or of stainless steel
- Customer specific connection plugs
- Connection cable according to EMV (using frequency control boxes)

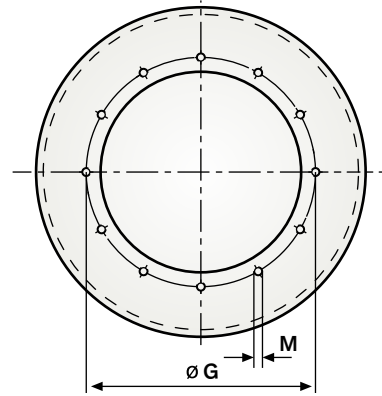

	SRC-B 250-2**	SRC-N 400-2	SRHL 400-2
	218	228	253
	290	440	470
	220/3	350/3	350/3
	M8	M10	M10
	M6 8x45°	M6 12x30°	M6 12x30°
	165	300	300
	186	320	320
	40	103	140
	2,6	4,05	5,3
	2,5	2,5	2,5
	100 Hz 6000 min	100 Hz 6000 min	100 Hz 6000 min
	200V 50Hz 200V 60Hz 110V 50Hz 110V 60Hz	200V 50Hz 200V 60Hz 110V 50Hz 110V 60Hz	200V 50Hz
	CE	CE, CSA/UL	CE, CSA/UL
	IP54	IP54	IP54
	Steel, painted RAL7035 light grey	Steel, painted RAL7035 light grey	Steel, painted RAL7035 light grey

SRC-N 63-2  
SRC-N 100-2

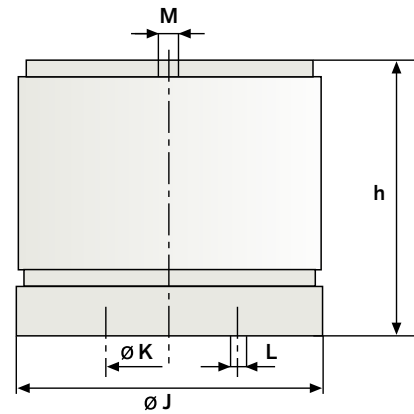

SRC-N 160-2  
SRC-N 200-2  
SRC-B 200-2

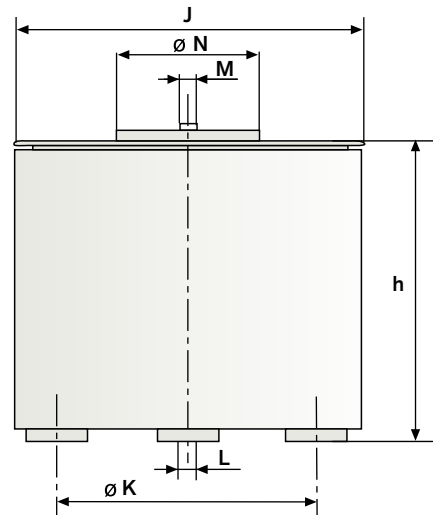

SRC-N 250-2  
SRC-B 250-2  
SRC-N 400-2  
SRHL 400-2

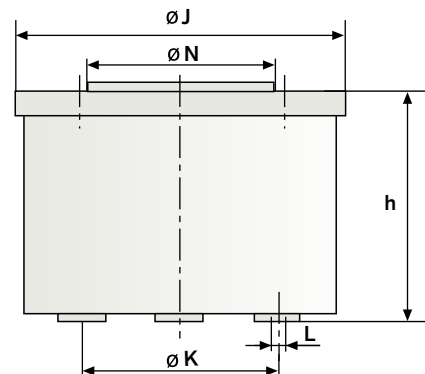

## Drive Units (-1 design)

Application area for

- 50 Hz vibration frequency (-1 design)
- for heavy additional mass in the bowl (e.g. extensive orienting devices)
- for minor noise emission
- drive unit will be more load sensitive by heavy loading (filling weight) compared to -2 design

Please advise feed direction when ordering (see also page 5).  
Subject to manufacturing tolerances.

Type	SRC-N 400-1	SRHL 400-1	SRC-N 630-1	SRC-N 800-1
h = Drive unit height/ Top casting	228	255	227	315
J = Drive unit diameter	440	470	660	826
K = Pitch between mountings/no. of bores	350/3	350/3	560/3	735
L = Thread dimensions	M10	M10	M10	M10
M = Bowl fixing	M6 12x30°	M6 12x30°	M6 12x30°	-
N = Shoulder diameter	300	300	500	-
G = Bolt circle (Bowl fastening)	320	320	525	-
Drive unit weight [kg]	103	140	168	270
Rating in amps [A]	3,75	5,7	5	8,5
Length of connection cable* [m]	2,5	2,5	2,5	1,4
Vibration frequency	50Hz 3000min	50Hz 3000min	50Hz 3000min	50Hz 3000min
Nominal voltages (available on request with 220V)	200V 50Hz 200V 60Hz 110V 50Hz 110V 60Hz	200V 50Hz 110V 60Hz	200V 50Hz 200V 60Hz 110V 50Hz 110V 60Hz	200V 50Hz 200V 60Hz 110V 60Hz
Execution standard	CE, CSA/UL	CE, CSA/UL	CE, CSA/UL	CE, CSA/UL
Protection type	IP54	IP54	IP54	IP54
Protective casing (special painting on request)	Steel, painted RAL7035 light grey	Steel, painted RAL7035 light grey	Steel, painted RAL7035 light grey	Steel, painted RAL7035 light grey

\* Longer connection cables are available upon request

We are also manufacturing RNA bowl drives according to your specification, as for example:

- extra springs
- cover with special paint or of stainless steel
- Customer specific connection plugs
- Connection cable according to EMV (using frequency control boxes)

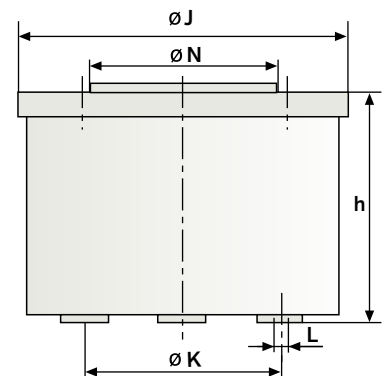
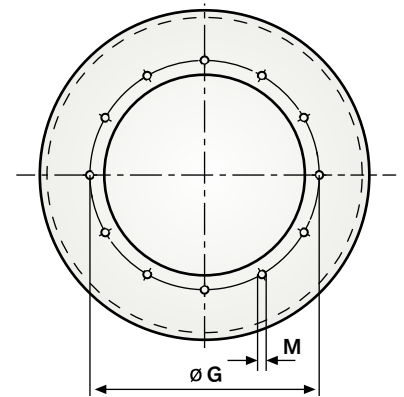

SRC-N 400-1  
SRHL 400-1  
SRC-N 630-1

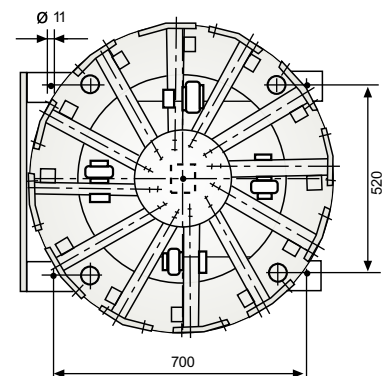
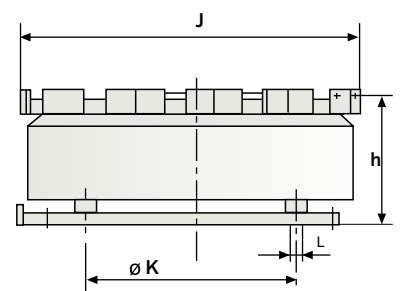

SRC-N 800-1



## Control Boxes

RNA provides state of the art controllers for all vibratory drive units. These range from low cost units to self-calibrating high-tech controllers using microprocessor technology to control external sensors and to provide communication signals. These are specially designed to meet the requirement of the bowl feeder industry. All controllers are CE approved and also available with CSA/UL certification.



For a detailed overview with respective assignments for the drive units please refer to page 22 to 23. Further information you will find in the separate catalogue for RNA control boxes or at [www.rnaautomation.com](http://www.rnaautomation.com) and [www.rna.de](http://www.rna.de)

## Sound Covers

Reduce noise and protect against dust and contamination.

### Sound Cover Type HK-S

- Suitable for bowl feeder from SRC-N 250 to SRC-N 630 with base plate type SRG
- Stainless steel with acoustic material
- RAL 7035 (outside), structure painted light-grey, special paints available on request
- Lid made from polycarbonate for sizes 400 and above, a hinged lid is available as an option

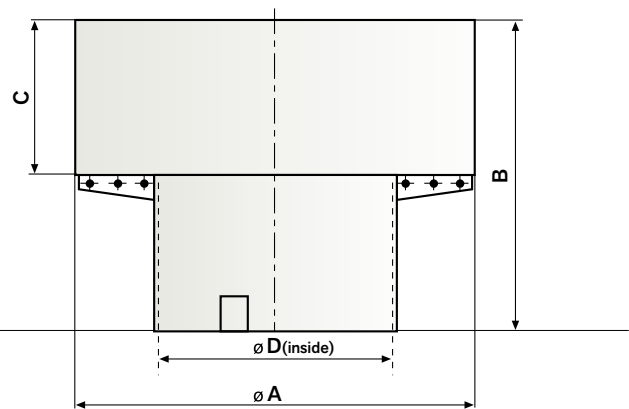

Type	HK-S 250	HK-S 400	HK-S 630
A* = Total diameter	550	880	1100
B* = Total body height	435	525	565
C* = Upper body height	230	310	350
D = Inner diameter	333	488	723

\* Measurements of A, B, C are variable

# Base Plates

Base plates enable easy mounting of the drive unit to the machine bed. The base plate SRG hat integrated fixing devices for the mounting of control units. When using a top plate type UP, UL and UK, base plates are necessary (see page 21, stands and top plates).

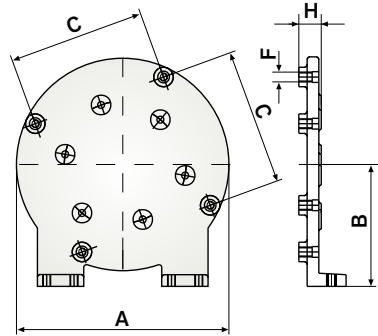

SRG-N 160/200

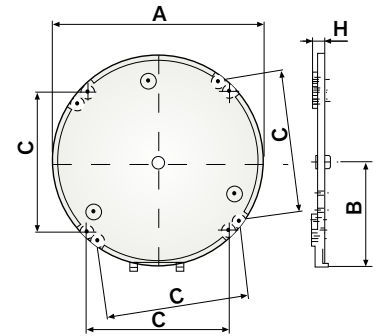

SRG-N 250/400/630

Type	SRG-N 160	SRG-N 200	SRG-N 250	SRG-N 400	SRG-N 630
A = Plate diameter	218	218	332	485	720
B = Position of control box mounting	125	125	172	253	375
C = Fixing hole centres	140	140	220	325	488
F = Thread size	M8/Km6	M8/Km6	M10/Km8	M10	M10
H = Plate height	23	23	32	32	35

Base plates SRG-N are aluminium and black powder coated

Type	USJ 160	USJ 200	USJ 250	USJ 400	USJ 630
A = Outside diameter	245	248	402	568	793
C = Fixing hole centres	202	202	332	502	698
F = Thread size	M6	M6	M8	M8	M8
H = Plate height	40	45	50	50	60

Base plates USJ are made of steel, black powder coated, adjustable height.

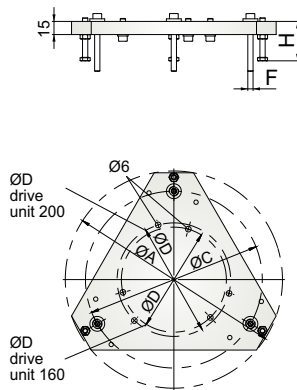

USJ 160/200

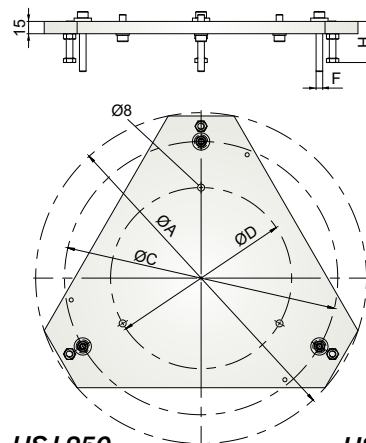

USJ 250

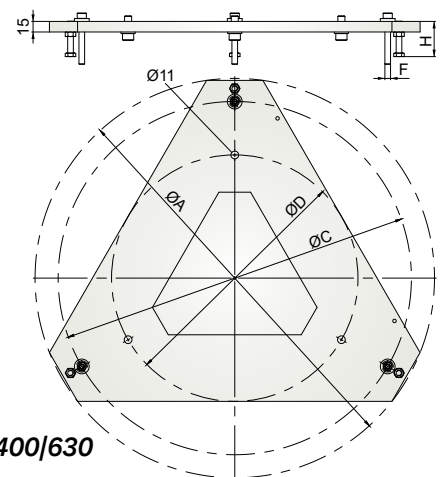

USJ 400/630

# Stands and Top Plates

RNA stands and top plates have a large height regulating range. Due to their finely adjustable regulation, they also enable an optimal interface compensation at the workpiece discharge points. The drill template for the top plate serves to mount the relevant size of the SRG type base plate.

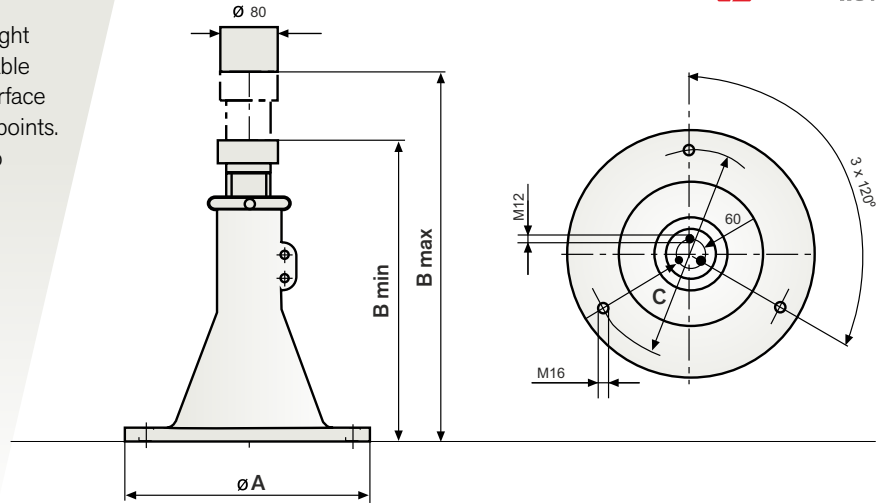

Feeder stands consist of cast iron pedestal, painted RAL 6011 and fitted with an adjustable threaded column.

Feeder stand type	UG 400-535	UG 400-735	UG 400-935	UG 630-535	UG 630-735	UG 630-935
A	400	400	400	630	630	630
B min.	535	735	935	535	735	935
B max.	790	990	1190	790	990	1190
C	340	340	340	560	560	560

Top plate type	UP-120*	UP-250	UP-400	UP-630
A	120	250	380	550
B	20	21	21	21
C	100	220	325	488

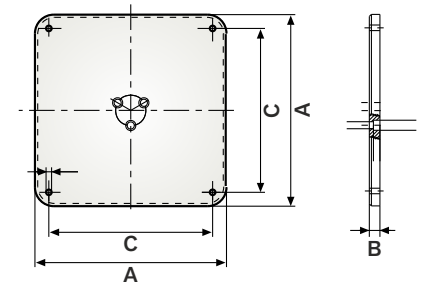

Top plate type UL, 80mm\*\* adjustable only in one direction

Top plate type	UL-250	UL-400	UL-630
A	250	380	550
B	44	44	44
C	220	325	488
Total traverse path X	54	83,5	82

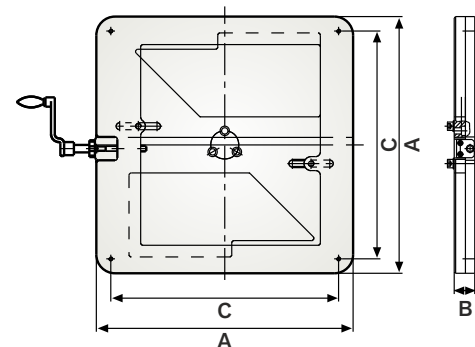













Top plate type UK, 80mm\*\* adjustable in both directions

Top plate type	UK-250	UK-400	UK-630
A	250	380	550
B	64	64	64
C	220	325	488
Total travel X-axis	83,5	83	83,5
Total travel Y-axis	70	83	82

\* For use with special baseplates | \*\* As an accessory, it is necessary to have a prolonged crank

## Bowl Feeders

Size	63	100	160	200
 <b>Drive units</b>	SRC-N 63-2	SRC-N 100-2	SRC-N 160-2	SRC-N 200-2 SRC-B 200-2
 <b>Cylindrical bowls</b>	ZAD-Z 63-4-18	ZAD-Z 100-6-50	ZSD-Z 160-12-70 ZSB-Z 160-12-70	ZSB-Z 200-12-80
 <b>Conical bowls</b>	KAD-Z 63-4-30	KAD-Z 100-4-40		KSB-Z 200-18-55 KSB-ZA 200-5RG-150
 <b>Stepped bowls</b>				TAG-Z 200-10-80 TAG-Z 200(324)-20-105
 <b>Synthetic bowls</b>	on request	KKF-Z 100-X-40 TKF-Z 100-X-40	KKF-Z 160-X-65 TKF-Z 160-X-65	KKF-Z 200-X-65 TKF-Z 200-X-65
<b>Adapter plates</b>				
 <b>Fixed bowl centre</b>				
<b>Rotating bowl centre</b>				
 <b>Control box compatibility</b>	ESG 1000 ESG 2000 ESK 2000 ESK 2001	ESG 1000 ESG 2000 ESK 2000 ESK 2001	ESG 1000 ESG 2000 ESK 2000 ESK 2001	ESG 1000 ESG 2000 ESK 2000 ESK 2001
<b>Control box compatibility frequency controller</b>	ESR 2000 ESR 2500	ESR 2000 ESR 2500	ESR 2000 ESR 2500	ESR 2000 ESR 2500
 <b>Control box (din rail mounted type)*</b>	ESM 906/910	ESM 906/910	ESM 906/910	ESM 906/910
 <b>Baseplate</b>			SRG/USJ 160	SRG/USJ 200
 <b>Sound cover</b>				
 <b>Feeder stand type together with threaded column</b>				
<b>Top plate for feeder stand</b>				
 <b>X movement slide for feeder stand</b>				
<b>X/Y movement slide for feeder stand</b>				

\*This only applies to a main connection voltage of 230V/ 50-60 Hz

**Bowl type**  
 Z = cylindrical  
 K = conical  
 T = stepped

**Material**  
 A = Aluminium  
 S = Stainless Steel  
 K = Polyamide

**Size**  
 X = variable

**Width of track (mm)**  
 X = variable

**bowl height**  
 from the screwing on point

RNA-Code for bowls:

**K S B - Z A - 250 - 8 (R G) - 150**

**Design**

B = steel metal construction  
 D = turned  
 F = machined  
 G = cast

**Centres/different fixings**

N = nothing, additional centres required  
 Z = welded bottom with centre fixing  
 B = welded bottom only,  
 A = adapter plate  
 2A = additional adapter plate for centre fixing

**Track type**

R = rectangular,  
 G = closed

	250	400	630	800
	SRC-N 250-2 SRC-B 250-2	SRC-N 400-2 SRHL 400-1 SRC-N 400-1 SRHL 400-2	SRC-N 630-1	SRC-N 800-1
	ZSB-N 250-30-110 ZSB-ZA 250-30-125	ZSB-N 400-30-160 ZSB-BA 400-30-175 ZSB-Z2A 400-30-190	ZSB-N 630-50-180 ZSB-BA 630-50-195	ZSB-B 800-80-220
	KSB-N 250-20-90 KSB-ZA 250-20-105 KSB-ZA 250-20-150 KSB-ZA 250-8RG-150	KSB-N 400-50-160 KSB-BA 400-50-175 KSB-BA 400-15RG-220 KSB-Z2A 400-50-190 KSB-Z2A 400-15RG-235	KSB-N 630-50-180 KSB-BA 630-50-190 KSB-BA 630-15RG-250	KSB-N 800-80-170
	TAG-N 250-20-105 TAG-N 250-32-130 TAG-N 250-32-145 TAG-ZA 250-32-165 TAG-ZA 250(541)-32-180	TAG-N 400-32-175 TAG-N 400-50-190 TAG-N 400-50-215 TAG-ZA 400-50-240	TAG-N 630-50-220 TAG-N 630-65-230 TAG-ZAB 630-50-240 TAG-ZAB 630-65-250	
	KKF-ZA 250-X-100 TKF-ZA 250-X-100	on request		
	AAG-Z 250	AAG-R 400 AAG-Z 400 AAG-Z 400(Z)	AAG-R 630 AAG-Z 630	
	SRF-N 250(PA) SRF-N 250(AL) SRF-N 250(VA)	SRF-N 400(PA) SRF-N 400(AL) SRF-N 400(VA)	SRF-Z 630 (AL) <small>nur für TAG-ZAB</small> SRF-N 630(AL) SRF-N 630(VA)	
	SRL-N 250(PA) SRL-N 250(AL)	SRL-N 400(PA) SRL-N 400(AL)	SRL-N 630(AL)	
	ESG 1000 ESG 2000 ESK 2000 ESK 2001	ESG 1000 ESG 2000 ESK 2000 ESK 2001	ESG 1000 ESG 2000 ESK 2000 ESK 2001	ESG 2000 ESK 2000
	ESR 2000 ESR 2500	ESR 2000 ESR 2500/2800	ESR 2000 ESR 2500/2800	ESR 2800
	ESM 906/910	ESM 906/910	ESM 906/910	ESM 910
	SRG/USJ 250	SRG/USJ 400	SRG/USJ 630	
	HK-S 250	HK-S 400	HK-S 630	
	UG 400-535 UG 400-735 UG 400-935	UG 630-535 UG 630-735 UG 630-935	UG 630-535 UG 630-735 UG 630-935	
	UP 250	UP 400	UP 630	
	UL 250	UL 400	UL 630	
	UK 250	UK 400	UK 630	





**RNA Group**

*Headquarter  
Production and Sales*

**Rhein-Nadel Automation GmbH  
Reichsweg 19-23  
D-52068 Aachen**

*Tel. Sales:*  
**+49 (0) 241-5109-0**  
*Fax Sales:*  
**+49 (0) 241-5109-219**  
*Email:*  
**vertrieb@rna.de  
www.RNA.de**



*Production and Sales  
Focus: pharmaceutical industry*

**PSA Zuführtechnik GmbH  
Dr.-Jakob-Berlinger-Weg 1  
D-74523 Schwäbisch Hall**  
Tel.: +49 (0) 791 9460098-0  
Fax: +49 (0) 791 9460098-29  
Email: info@psa-zt.de  
www.psa-zt.de



*Production and Sales*

**RNA Automation Ltd.  
Unit C Castle Bromwich Business Park  
Tameside Drive, Birmingham B35 7AG  
United Kingdom**  
Tel: +44 (0)121 749 2566  
Fax: +44 (0)121 749 6217  
Email: sales@rnaautomation.com  
www.rnaautomation.com



*Production and Sales*

**HSH Handling Systems AG  
Wangenstr. 96  
CH-3360 Herzogenbuchsee  
Schweiz**  
Tel.: +41 (0) 62 956 10-00  
Fax: +41 (0) 62 956 10-10  
Email: info@handling-systems.ch  
www.handling-systems.ch



*Production and Sales*

**Pol. Ind. Famades C./Energia 23  
E-08940 Cornellà de Llobregat (Barcelona)  
Spanien**  
Tel: +34 (0)93 377-7300  
Fax: +34 (0)93 377-6752  
Email: info@vibrant-RNA.com  
www.vibrant-RNA.com  
www.vibrant.es

**[www.RNA.de](http://www.RNA.de)**