

## Operating Instructions

Controller  
for vibratory drive systems

ESK 2001

# Table of Contents

1.	About this document .....	4
2.	Safety directives.....	4
2.1.	Design of safety directives .....	4
2.2.	Fundamental safety directives .....	4
2.3.	Personnel.....	4
2.4.	Intended use .....	5
2.5.	Residual hazards .....	5
2.5.1.	Device .....	5
2.5.2.	Protection of the drive system .....	5
2.5.3.	Degree of protection - Protection of persons and equipment .....	5
3.	Product information .....	6
3.1.	Characteristic features .....	6
3.2.	Applicable directives and standards.....	6
3.3.	Technical data.....	6
3.4.	Accessories .....	7
4.	Notes on start-up.....	7
4.1.	Modes of operation .....	7
4.2.	Automatic mode change .....	8
4.3.	Sensor inputs and sensor linkages .....	8
4.4.	Sensor connection .....	9
4.5.	Status outputs and relays .....	10
5.	Operation .....	10
5.1.	General.....	10
5.2.	Starting-up the controller.....	11
5.3.	Main menu / Setpoint entry and display for channels 1 and 2.....	11
5.4.	Description of individual codes for controller programming.....	12
5.5.	Application-specific change of default settings .....	14
5.5.1.	Code C001 for channel 1 and code C002 for channel 2 (feed rate outputs) .....	14
5.5.2.	Code C003 Seal setpoint .....	14
5.5.3.	Code C004 sensor input 1 and code C005 sensor input 2 .....	14
5.5.4.	Code C006 Sensor linkage.....	15
5.5.5.	Code C008 cycle monitoring .....	16
5.5.6.	Code C009 Show status.....	17
5.5.7.	Code C200 Inhibiting all code entries.....	17
5.5.8.	Code C100 Setting the feed rate by external voltage input. ....	17
5.5.9.	Code C143 Saving parameters .....	18
5.5.10.	Code C210 Retrieving parameters.....	18
6.	Dimensioned drawing.....	18
7.	Connection diagram .....	19



## Declaration of Conformity

According to the Low-Voltage Directive 2014/35/EU  
and Electromagnetic Compatibility Directive 2014/30/EU

We hereby declare that the product meets the following requirements:

Low-Voltage Directive 2014/35/EC  
Electromagnetic Compatibility Directive 2014/30/EU

The following harmonized standards have been applied: DIN EN 60204 T1, EN 61439-1

See separate Declaration of Conformity provided on delivery

### Remarks:

The controllers have been manufactured in accordance with the Low Voltage Directive 2014/35/EU and are thus EMC-compliant and tested. We assume that our product will be incorporated into a stationary machine. The requirements of the EMC Directive 2014/30/EU must be satisfied by the user.

Rhein-Nadel-Automation  
-----

Managing Director  
Jack Grevenstein



## 1. About this document



### **Attention**

Read this document carefully and observe the safety directives before commencing any work.

### **Document description:**

This document provides assistance in choosing your product. You will also find information on mechanical and electrical installation, operation, product extensions and accessories.

Non-observance may cause trouble with the product or the environment, reduce the product lifetime or lead to other damage.

## 2. Safety directives

### 2.1. Design of safety directives



#### **Notice**

This notice identifies useful tips for use of the controller.



#### **Attention!**

This symbol identifies hazardous situations.

Non-observance of such warnings may cause irreversible injury or even death!

### 2.2. Fundamental safety directives

Non-observance of the following fundamental safety measures and directives may lead to severe injury and damage to property!

Meeting the requirements given in the related documentation is a precondition for safe and trouble-free operation and for achieving the product properties specified. Further additional safety directives in the other sections must be observed as well.

### 2.3. Personnel



#### **Attention!**

Any work on electrical equipment of the machine/system shall be carried out exclusively by a professional electrician, or by instructed persons working under the direction and supervision of a professional electrician, according to electrotechnical rules.

Only qualified professionals are allowed to work on or with the product. IEC 60364 or CENELEC HD 384 define the qualification of these persons:

- They are familiar with set-up, installation, commissioning and operation of the product.
- They possess the qualification required for performance of their work.
- They know all regulations for the prevention of accidents, directives and laws applicable to set-up, installation and commissioning on site, and they are able to apply the same.
- They have knowledge and skills of First Aid.

## 2.4. Intended use

Please observe the following directives for intended use of the controllers:

- The devices herein described must only be stored, fitted and operated under the conditions specified in this documentation.
- Here you are not concerned with domestic devices! They are solely intended to be used as components for commercial or professional applications pursuant to EN 61000-3-2.
- They satisfy the protection requirements of 2014/35/EU: Low Voltage Directive.
- They do not constitute a machine as defined by 2006/42/EU: Machinery Directive.
- A machine comprising the product must not be commissioned or put into operation for the intended use until it has been declared to be in conformity with the EC Directive 2006/42/EU: Machinery Directive; Observe EN 60204-1.
- Commissioning or starting operation for the intended use is only permitted in compliance with the EMC Directive 2014/30/EU.
- Use of the product in living areas may lead to EMC disturbance. The user is responsible for taking interference suppression measures.
- They are optimised for operation of RNA bowl feeders and linear feeders. Observe the limits indicated in the technical specification.

### Attention!



- Prior to start-up make sure that the protective earth conductor is connected and in proper condition. Make the PE conductor test with approved test devices only.
- Never start up despite detected damage.
- Do not make any technical modifications to the device, except as described in this document.
- Never start up in an incompletely installed state.
- Never operate the device without the required guards in place.
- Connect, disconnect or change any electrical connections only in the absence of voltage.

## 2.5. Residual hazards

Residual hazards may remain even if all directives have been observed and protective measures taken. Such residual hazards must be considered by the user in the risk assessment of his machine/equipment. Non-observance may lead to severe injury and damage to property!

### 2.5.1. Device

Pay attention to the warning signs fitted to the device!

Symbol	Description
	<b>Hazardous voltage:</b> Prior to commencing any work on the product check for absence of voltage on all power connections.
	Leakage current: Make fixed installation and PE connection according to EN 60204-1!

### 2.5.2. Protection of the drive system

Certain device parameter settings may overheat the connected drive magnet, e.g., by prolonged operation with the wrong current range set.

### 2.5.3. Degree of protection - Protection of persons and equipment

- All specifications relate to installed condition ready for operation.
- All slots not used must be closed by protection caps or dummy plugs in order not to reduce the protection against accidental contact.

## 3. Product information

### 3.1. Characteristic features

The compact controller is designed for operation of a combination of bowl feeder and linear feeder or bowl feeder and hopper. Channel 2 can be switched over to belt drive.

The unit offers the following characteristic features:

- Two feed rate outputs
- Channel 1 bowl feeder, linear feeder max. 10A, variable
- Channel 2 linear feeder max. 4A, variable or AC capacitor motor max. 3A, not variable
- Two sensor amplifiers with independently adjustable timers (On/Off delay).
- External enabling inputs 24 VDC
- Two relay outputs and two optocouplers for status messages and other links.
- Membrane keypad for setting and changing the operating parameters in the set-up menus.
- Plug-type connections for
  - vibratory drive / belt drive
  - Sensors
  - Communication with higher-level controller
- Bipolar main disconnect switch.

### 3.2. Applicable directives and standards

The controller is compliant with the following standards:

**EC EMC Directive 2014/30/EU**  
**EC Low Voltage Directive 2014/35/EU**

The applicable standards are specified in the Declaration of Conformity.

**The controller is also available in a UL/CSA compliant version.**

### 3.3. Technical data

<b>Supply voltage:</b>	230 V AC, 50/60 Hz, +20 / -15% 115 V AC, 50/60 Hz, +10 / -10%
<b>Output voltage:</b>	0 ... 208 V <sub>eff</sub> ; (230VAC in motor mode) at 230V supply voltage 0 ... 98V <sub>eff</sub> ; (115VAC in motor mode) at 115V supply voltage
<b>Channel 1 load current:</b>	10 A <sub>eff</sub>
<b>Channel 2 load current:</b>	4 A <sub>eff</sub> ; in motor mode 3A
<b>Total load current:</b>	10 A <sub>eff</sub>
<b>Minimum load current:</b>	80 mA
<b>Internal fusing:</b>	F1 = 10AmT / F2 = 4AmT
<b>Soft start delay, soft stop delay both channels:</b>	0 ... 5 sec. separately selectable
<b>External setpoint:</b>	0 ... 10V DC
<b>Sensor inputs:</b>	2
<b>2 Enabling inputs:</b>	24V DC (10-24VDC)
<b>Sensor supply:</b>	24V DC, max. 60 mA (per sensor input)
<b>Sensor ON delay:</b>	0 ... 60 sec. separately adjustable
<b>Sensor OFF delay:</b>	0 ... 60 sec. separately adjustable
<b>Outputs:</b>	2 relays (max. 6A 250VAC) 2 floating changeover contacts 2 normally-open contacts carrying supply voltage
<b>Status output:</b>	2 optocouplers, max. 30VDC 10mA,
<b>Ambient temperature:</b>	0 ... 50° C
<b>Degree of protection:</b>	IP 54

### 3.4. Accessories

Tag	Designation	RNA Part No.
XS1	Load connector, 5-pin	31002323 (100Hz drives)
XS1	Load connector, 5-pin	31002322 (50Hz drives)
XS3	Coupling plug, 5-pin, straight	35051144
XS3	Coupling plug, 5-pin, angular	35002546
XS4	Coupling socket, 7-pin, straight	35051153
XS4	Coupling socket, 7-pin, angular	35002545
For XS3	Y adapter	39905940

## 4. Notes on start-up

Make sure that following points are checked prior to making connection to power supply and switching on the controller:



- Is the controller casing properly closed with all screws tightened?
- Are all plug hooks engaged / firmly screwed in place?
- Are all cables and glands in proper condition?
- Is operation for the INTENDED USE made sure?
- Does the supply voltage specified on the controller match the local supply system?
- Does the supply frequency specified on the vibratory drive match the local supply system?
- Is the correct mode set on the controller? (See description under "Modes of Operation")

Only if you can clearly answer all the above questions with "Yes" must the controller be put into operation.



### Attention:

Set the controller to minimum output before switching-on for commissioning or start-up after repairs or replacement of controllers/vibratory drives. Then watch proper operation while the output is increased.

### 4.1. Modes of operation

RNA vibratory drive systems employ mechanical spring vibrators which are set to a vibrating frequency near the mains frequency or near double mains frequency depending on weight and/or size.

This is why two modes of operation are possible:

Mode 1: Asymmetric half-wave mode:  
The vibrating drive at mains frequency.

Mode 2: Symmetric full-wave mode:  
The vibrating drive operates at double mains frequency.

To assist the operator the cable glands on the drive connector are colour-coded.

Mode 1: black  
Mode 2: Grey

In terms of the vibrating frequency this means:

	Mains frequency 50 Hz	Mains frequency 60 Hz	Cable gland colour
<b>Mode 1 Half-wave mode</b>	Vibration frequency 50 Hz $\pm$ 3000 min <sup>-1</sup>	Vibration frequency 60 Hz $\pm$ 3600 min <sup>-1</sup>	black
<b>Mode 2 Full-wave mode</b>	Vibration frequency 100 Hz $\pm$ 6000 min <sup>-1</sup>	Vibration frequency 120 Hz $\pm$ 7200 min <sup>-1</sup>	Grey

## 4.2. Automatic mode change

Vibratory drive systems by RNA do not require the operator to take care of selecting the right operating mode. The operating mode is determined by a code in the RNA vibrating drive connector. A wire jumper from pin 3 to 4 in the connector switches the controller to mode 2: 100 or 120 Hz. In the absence of this wire jumper the controller operates in mode 1: 50 or 60 Hz.

The RNA vibratory drive systems come with the right code in the connector.

A mode change is made only and exclusively via the code in the vibratory drive connector!

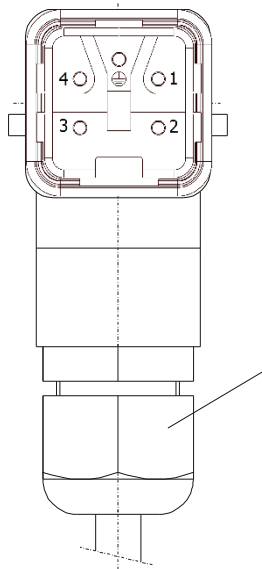

### M20 gland

Black: 50/60Hz vibrating frequency  
Grey: 100/120Hz vibrating frequency  
(EMC metal gland if frequency controllers are used.)

(Where frequency controllers with selectable output frequency are used, an EMC metal gland and a shielded cable are provided.)

## 4.3. Sensor inputs and sensor linkages

The controller has two sensor inputs which are used for accumulation checking, level checking, cycle monitoring and other monitoring functions. The following basic assignments are made:

Sensor input 1 acts on channel 1, unless otherwise programmed in menu C006.

Sensor input 2 acts on channel 2.

The sensor inputs can be evaluated only if they are activated. For sensor connection (connector XS3) please refer to the connection diagram.



#### 4.4. Sensor connection

The controller has two sensor inputs which can be used for accumulation checking and/or level monitoring purposes. You can connect sensors of type NPN or PNP.

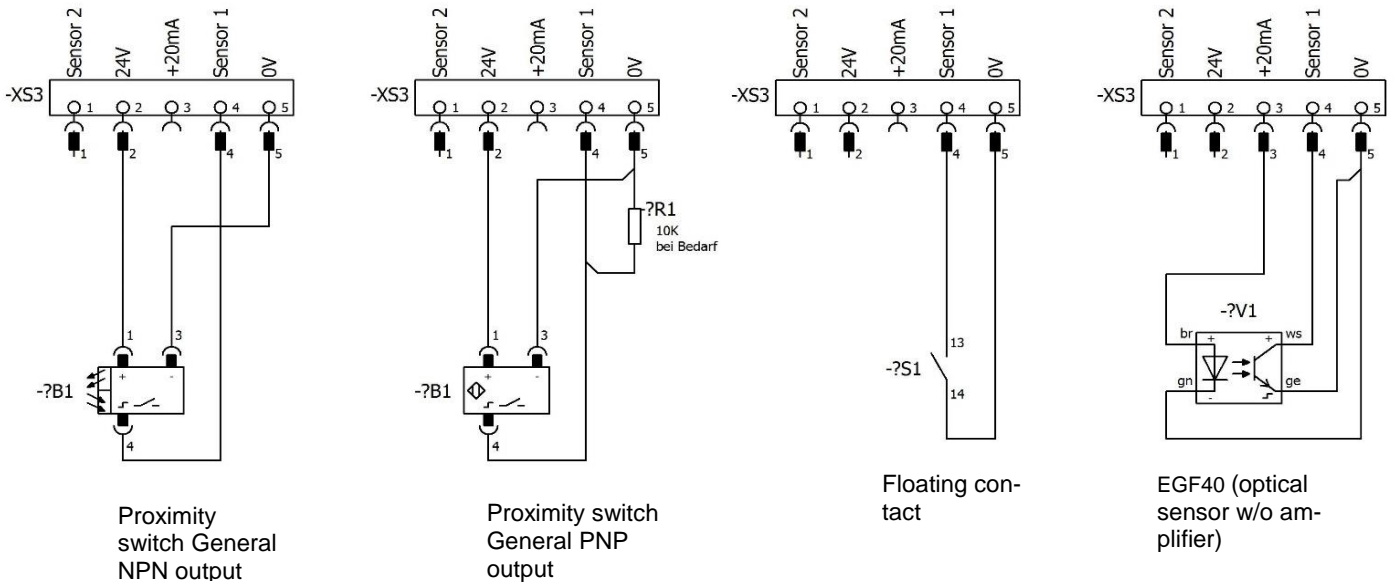

PNP switching sensors may require a 10K resistor between sensor output and 0V.

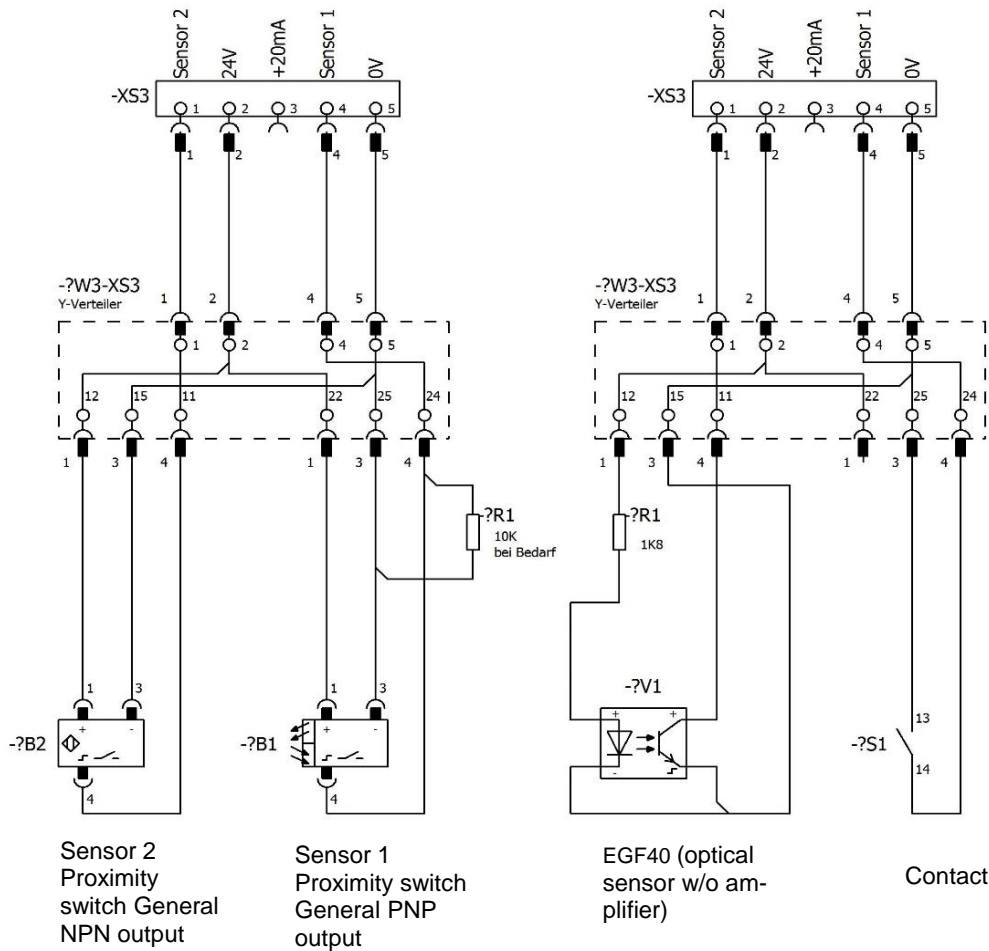

### Connection of 2 sensors via Y adapter

## 4.5. Status outputs and relays

The status outputs are used for remote diagnostics of the controller status or of the links of several controllers with one another.

They are designed as freely available NPN-doped transistor circuits and they are floating.

With the status output **READY** the transistor circuit is switched through whenever the controller is connected to power supply and switched on by its power switch closed.

The status output **ACTIVE** requires the same conditions for switching-through as "READY". In addition, channel 1 must be operating actively, the transistor blocks in case of ACCUMULATION, OFF or STOP. The status outputs as well as the external enabling inputs are to be wired via plug connector XS4.

The two relays have different functions. K1 operates as a status relay parallel to the **ACTIVE** status output. K2 serves either for a blowing air switch-off delay (4 sec.) or for cycle monitoring of one of the two sensor channels.

Connections and cable entry are on the right-hand side of the controller with the terminal block behind the panel.

## 5. Operation

### 5.1. General

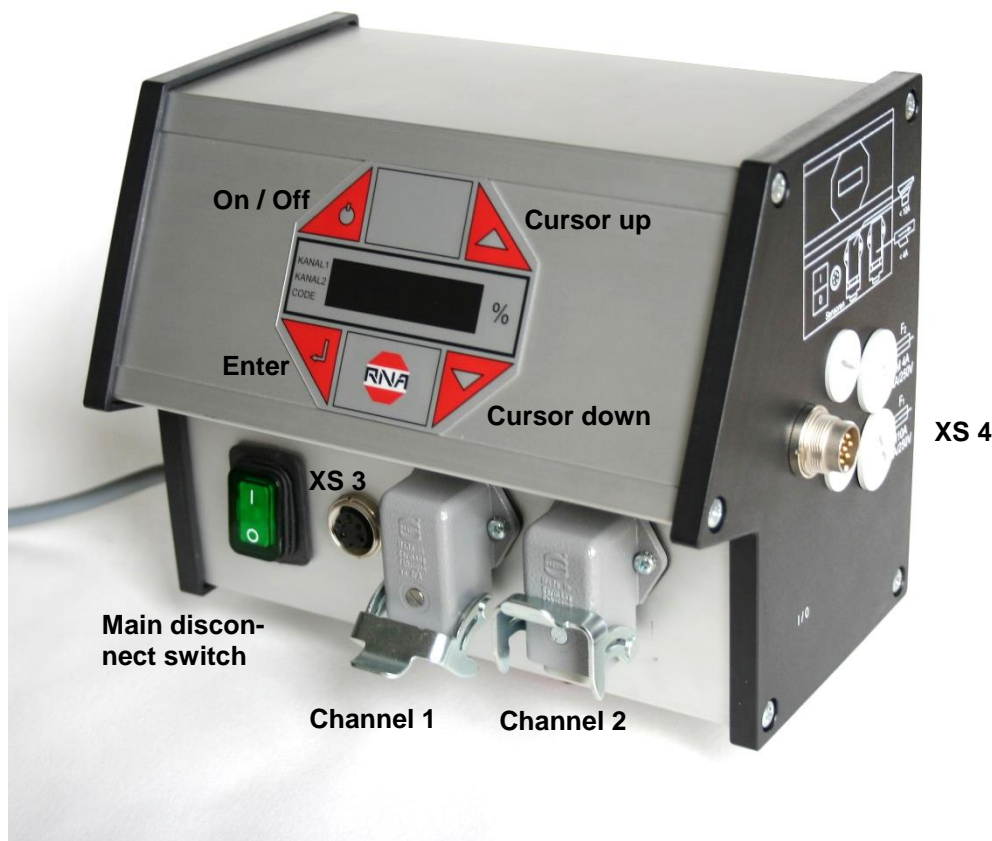

### Controller plug connections

<u>Main disconnect switch</u>	Double-pole isolation of the controller from power supply
<u>XS 3</u>	Connector for sensors
<u>Channel 1</u>	Connector for bowl feeder (<10 A)
<u>Channel 2</u>	Connector for linear feeder or AC capacitor motor (<4 A)
<u>XS 4</u>	Connector for optocoupler outputs and external enabling inputs

## The controller display (membrane keypad)



### On / Off

Pressing this button switches off all connected devices. The display shows "OFF". The controller remains ready for operation.



### Cursor up and cursor down

Use these buttons to scroll through the controller menu or set the parameters.



### Enter

Press this button to acknowledge the parameters entered with the cursor.

### Decimal point in the display

The decimal point is not blinking. You cannot make any entry.



The decimal point is blinking, an entry can be made.

## 5.2. Starting-up the controller

To start up the controller, close the main disconnect switch. The main menu appears on the display showing the last setpoint entered in channel 1 (feed rate of the bowl feeder).

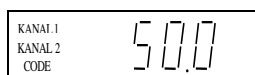

Alternatively, the following may appear on the display depending on the switching status of the device:

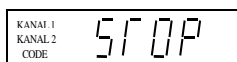

External enabling signal has been activated but it is withdrawn from the device at the moment. (medium priority)

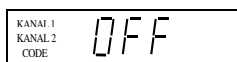

Device has been switched off by operating the top left button of the membrane keypad, inhibiting all functions. (highest priority)

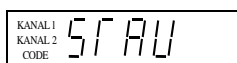

The accumulation monitoring sensor is operated, switching off channel 1 (the vibratory feeder). (low priority)

## 5.3. Main menu / Setpoint entry and display for channels 1 and 2

Display of setpoint or feed rate (vibratory feeder)

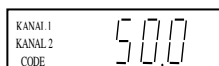

No entry possible

Alternatively: STOP, OFF or ACCUMULATION (see above)



Entry of the codes to change or execute the required settings.

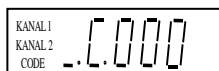

Enter code.

Description of codes see under 4.4.



Setpoint entry for channel 1 (bowl feeder or linear feeder)

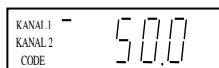

Entry in %; return to display mode for saving



Setpoint setting for channel 2 (linear conveyor or belt hopper with alternating capacitor current motor) (not effective with belt drive)

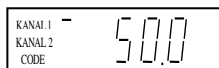

Input in %; back to display mode for saving



From these four basic screens of the main menu you can scroll in the main menu using the cursor buttons (UP/DOWN). In each individual item of the main menu you can press ENTER to activate this item for setting or changing. Upon pressing of the ENTER button the decimal point starts blinking. Now you can make changes using the cursor buttons (UP/DOWN). Press ENTER again to acknowledge the entries made. The decimal point is no longer blinking. Using the cursor buttons you can continue scrolling in the menu. Same procedure analogously applies to the code menus described below.

All the following display screens show the default setting. If the actual display on the controller differs the default setting has been changed in individual codes to suit a specific application.

## 5.4. Description of individual codes for controller programming.

KANAL 1  
KANAL 2  
CODE ..C.001

### Settings for channel 1

In this sub-menu you can set or limit the following functions for channel 1:

- Vibrating amplitude
- External enabling, signal direction of external enabling input
- Soft start and stop delay

KANAL 1  
KANAL 2  
CODE ..C.002

### Settings for channel 2

In this sub-menu you can set or limit the following functions for channel 2:

- Vibrating amplitude
- External enabling, signal direction of external enabling input
- Soft start and stop delay
- Selection of vibratory or belt feeder drive

KANAL 1  
KANAL 2  
CODE ..C.003

### Sealing a setpoint

In this sub-menu you can lock the setpoints (vibrating amplitude) of the main menu. It is no longer possible to change the setpoints for channel 1 and channel 2 in the main menu. This avoids accidental changes to performance parameters. You can only make any changes now through codes C001 and C002.

KANAL 1  
KANAL 2  
CODE ..C.004

### Setting the sensor input 1

This is the sub-menu for activation of sensor input 1. In addition you can set the following functions:

- Invert input signal direction
- Start delay
- Stop delay

KANAL 1  
KANAL 2  
CODE ..C.005

### Setting the sensor input 2

This is the sub-menu for activation of sensor input 2. In addition you can set the following functions:

- Invert input signal direction
- Start delay
- Stop delay

KANAL 1  
KANAL 2  
CODE ..C.006

### Choosing the sensor links

In this sub-menu you can link the sensors activated by codes C004 and C005 with one another.

KANAL 1  
KANAL 2  
CODE ..C.008

### Setting the cycle watchdog

Here you can set which sensor input is to be monitored and how the controller is to react to an error.

KANAL 1  
KANAL 2  
CODE ..C.009

### Show status

This sub-menu serves for checking of the set vibrating frequency and of the sensor inputs.

KANAL 1  
KANAL 2  
CODE ..C.010

### Calling-up the software version

Definition: 411. 57. 10. 23.11.99

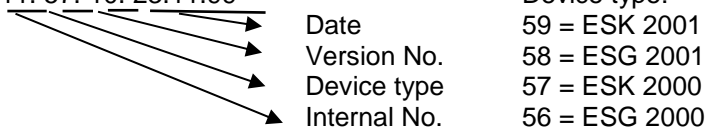

KANAL 1  
KANAL 2  
CODE ..C.100

### Setting the feed rate by external voltage input 0-10V or potentiometer

KANAL 1  
KANAL 2  
CODE ..C.143

### Saving parameters

You can save the (application-specific) settings previously made in various sub-menus under 143.

KANAL 1  
KANAL 2  
CODE ..C.200

### Inhibiting all setting functions

With the aid of this code you can disable all input facilities of the controller. It is no longer possible to change any values. The only way now to enable the menu again is through this code.

KANAL 1  
KANAL 2  
CODE ..C.210

### Retrieving parameters

Inn this sub-menu you can return the controller to the default settings. You can also return to

application-specific settings, if previously saved.

## 5.5. Application-specific change of default settings

### 5.5.1. Code C001 for channel 1 and code C002 for channel 2 (feed rate outputs)

<b>Select code</b>			<b>Set code</b>	
<b>Code C001</b>				
<b>Set vibrating amplitude</b>			<b>0 - 100 %</b>	
<b>Limit vibrating amplitude</b>			<b>50 - 100 % (*)</b>	
<b>External enabling</b>			<b>1 = active</b> <b>0 = not active</b>	
<b>External enabling signal direction</b>			<b>1 = Start = 24V DC</b> <b>0 = Stop = 24V DC</b>	
<b>Soft start delay</b>			<b>0 - 5 sec.</b>	
<b>Soft stop delay</b>			<b>0 - 5 sec.</b>	
<b>Switching to vibratory or belt feeder drive</b>			<b>0 = vibratory drive</b> <b>1 = belt drive</b>	
<b>Return</b>			<b>Save and return to main menu</b>	

(\*) For RNA feeders with 200 V magnets = 90 %

1) Only for channel 2: After removal of the enabling signal channel 2 switches off with a delay (5 minutes).

### 5.5.2. Code C003 Seal setpoint

**Objective:** Sealing-in the setpoints in the main menu. A direct change of the values is no longer possible. You can only make changes now through codes C001 and C002.

<b>Select code</b>			<b>Set code</b>	
<b>Code C003</b>				
<b>Setpoint (vibrating amplitude)</b>			<b>1 = adjustable</b> <b>0 = input inhibited</b>	
<b>Return</b>			<b>Save and return to main menu</b>	

### 5.5.3. Code C004 sensor input 1 and code C005 sensor input 2

**Objective:** Activating and setting the sensor inputs

<b>Select code</b>			<b>Set code</b>	
<b>Code C004</b>				
<b>Sensor 1 input</b>			<b>1 = active</b> <b>0 = not active</b>	
<b>Invert input signal direction</b>			<b>1 = Start = 24V DC</b> <b>0 = Stop = 24V DC</b>	
<b>Delay of sensor status CLEAR, Start delay</b>			<b>0 - 60 sec.</b>	
<b>Delay of sensor status OPERATED, Stop delay.</b>			<b>0 - 60 sec.</b>	
<b>Return</b>			<b>Save and return to main menu</b>	



Same applies analogously to code **C005** (sensor input 2).

### 5.5.4. Code C006 Sensor linkage

**Objective:** Linking of the two previously activated sensor inputs.

Select code

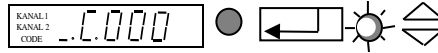

Set code



Code C006



You can activate only one of the eight sensor links at a time.

**AND logic with blowing-off the exit tracks**

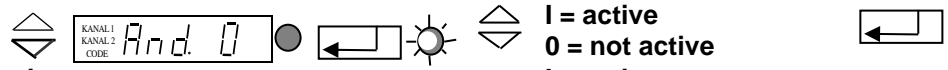

I = active  
0 = not active

**AND logic without blowing-off the exit tracks** (from version No. 10)

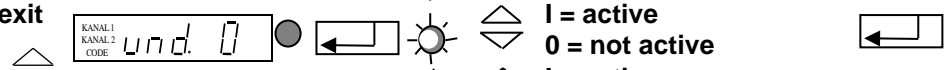

I = active  
0 = not active

**OR logic**

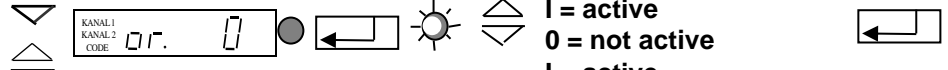

I = active  
0 = not active

**Min/Max logic**

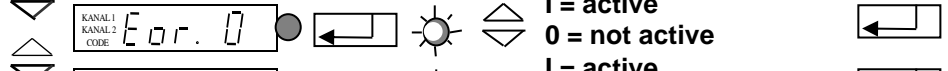

I = active  
0 = not active

**AND / S2 logic** (from version No. 10)

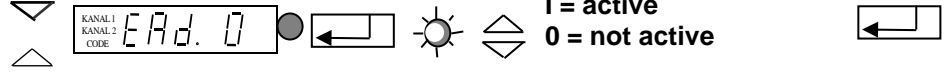

I = active  
0 = not active

**Level check with external control**

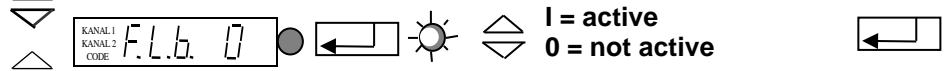

I = active  
0 = not active

**Level check with indicator light**

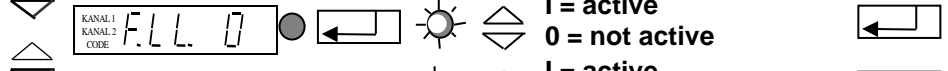

I = active  
0 = not active

**Individual link**

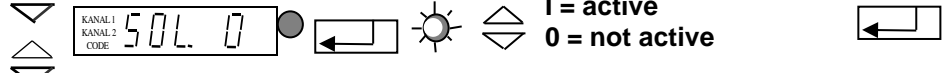

I = active  
0 = not active

Use the following two links to set priority of the channels.

**Channel 2 follows channel 1**

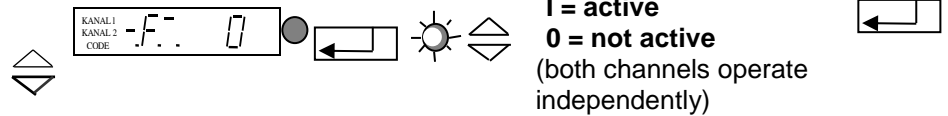

I = active  
0 = not active  
(both channels operate independently)

or !

**Channel 1 follows channel 2**

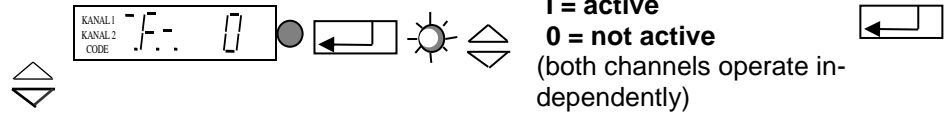

I = active  
0 = not active  
(both channels operate independently)

**Return**

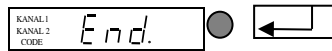

**Save and return to main menu**

#### Brief description of individual links

**AND logic of the two sensor inputs with blowing-off the exit track.**

**Example:**

**Application:** Twin-track feeders with accumulation checker.

**Solution:** Track 1 (sensor 1) full = Blow-off track 1 (relay K1)

Track 2 still clear

Track 2 (sensor 2) full = Blow-off track 2 (relay K2)

Track 1 still clear

Track 1 + Track 2 full = Bowl feeder (channel 1) Stop about 4 sec. later blowing air stop

**AND logic of the two sensor inputs without blowing-off the exit track.**

Bowl feeder (channel 1) stops when both sensors are operated. Orienting air can be switched off with delay (4 sec.) via relay K2.

**OR logic of the two sensor inputs.**

Bowl feeder (channel 1) stops when one of the two sensors is operated. Orienting air can be switched off with delay (4 sec.) via relay K2.



**Min/Max logic of the two sensor inputs.**

The bowl feeder stops when **both** sensors are operated. The vibratory feeder (channel 1) will re-start only after **both** sensors are cleared again.

Relay K1 operates on stopping of bowl feeder. Relay K2 operates 4 sec. later (stopping the blowing air)



**AND / S2 logic**

Vibratory feeder (channel 1) stops when both sensors are operated. It starts when sensor 2 is cleared again. Orienting air can be switched off with delay (4 sec.) via relay K2.



**Level check for hoppers with external hopper control**

Sensor 2 operates relay K1 following the delay period entered (C005).

When sensor 1 is operated, relay K1 drops out (hopper interlock).

Application: Sensor 1 = accumulation check  
Sensor 2 = level check  
Relay K1 = hopper control



**Level check with indicator light**

Sensor 2 operates relay K1 following the delay period entered (C005) without taking into account sensor 1 (accumulation check).

Application: Sensor 2 is used as a level checker (e.g., LC-N 24V DC). Relay K1 operates an indicator light: *Bowl feeder empty*.

**5.5.5. Code C008 cycle monitoring**

Objective: Monitoring of sensors 1 (accumulation check) and/or 2.

When activating the cycle monitoring function, the "AND, SOL" links in code C006 must not be activated!!!

Select code

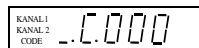

Set code



Code C008

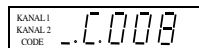

Sensor input 1 is monitored

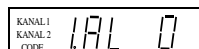

I = active  
0 = not active



Sensor input 2 is monitored

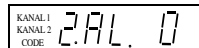

I = active  
0 = not active



Monitoring depending on Channel 1

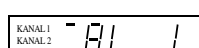

I = active  
0 = not active



Monitoring depending on Channel 2

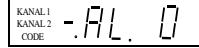

I = active  
0 = not active



Time till alarm comes up

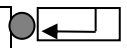
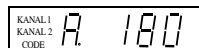

3 - 240 sec.



Switching off channel 1 and channel 2



I = see below  
0 = see below



Switch (relay K1)

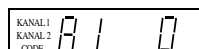

I = Alarm on relay K1  
0 = Alarm on relay K2



Return

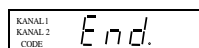

Save and return to main menu



The cycle watchdog monitors the CLEAR sensor status. The time (A 180) sets the maximum duration for which a sensor is allowed to be clear before an alarm message is generated.

In case of an alarm the relay K2 is clocked on and off. Reset takes place automatically when the sensor is operated again.



If **OUT = 1** the alarm operates relay K2 (indicator light: Error) and also stops the bowl feeder. An ERROR message appears on the panel display. Use the bottom right cursor button for reset.

If **OUT = 0** the alarm only operates relay K2 (indicator light: Error). Reset takes place automatically when sensor 1 is operated.



If **A.I. = 1** relay K1 is clocked on and off in response to the alarm (switching from relay K2 to relay K1).



### 5.5.6. Code C009 Show status

**Objective:** Checking of the set vibrating frequency and of the sensor inputs.

Select code			Set code	
Code C009				
External enabling signal Channel 1			I = active 0 = not active	
Channel 1 vibrating frequency			I = 50 Hz 0 = 100 Hz	
External enabling signal Channel 2			I = active 0 = not active	
Channel 2 vibrating frequency			I = 50 Hz 0 = 100 Hz	
Only ion controller mode				
Signal at sensor input 1			I = active 0 = not active	
Signal at sensor input 2			I = active 0 = not active	
Return			Save and return to main menu	

Under menu item HA = half wave you can check whether the operating mode (100 - 50 Hz) is selected correctly.

### 5.5.7. Code C200 Inhibiting all code entries

**Objective:** An (accidental) change of the set values by the user is not possible any more.

Select code			Set code	
Code C200				
Inhibiting the setting functions			I = enable 0 = disable	
Return			Save and return to main menu	

Only code C200 is accepted!!!  
You can change the setpoints for channels 1 and 2 in the main menu (see under 4.3).

### 5.5.8. Code C100 Setting the feed rate by external voltage input.

**Objective:** Setpoint change by external voltage

Select code			Select code	
Code C100				
External voltage application to channel 1			I = active 0 = not active	
External voltage application to channel 2			I = active 0 = not active	
Return			Save and return to main menu	

If external voltage application is activated the last digital feed rate set (%) constitutes the minimum feed rate for 0 volt. Set the maximum feed rate for 10 volt by the P parameter in C001 / C002.

Connect the external voltage to terminals 31, 32 and 33 in the controller.  
Terminal 31 = +10V  
Terminal 32 = E  
Terminal 33 = 0V



### Attention!

Before opening the device be sure to observe the safety directives in chapter 2.

## 5.5.9. Code C143 Saving parameters

**Objective:** Saving of application-specific parameters

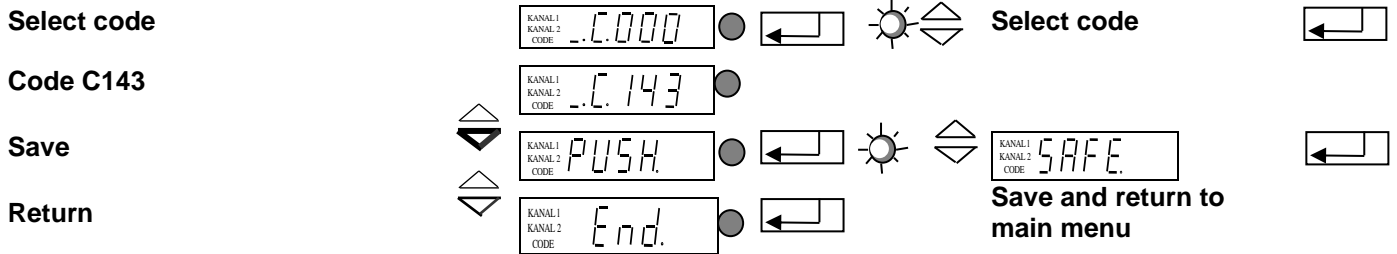

Having pressed ENTER to acknowledge PUSH you can save the selected parameters separately by pressing a cursor button.

## 5.5.10. Code C210 Retrieving parameters

**Objective:** Resetting to default values or retrieving stored application-specific settings

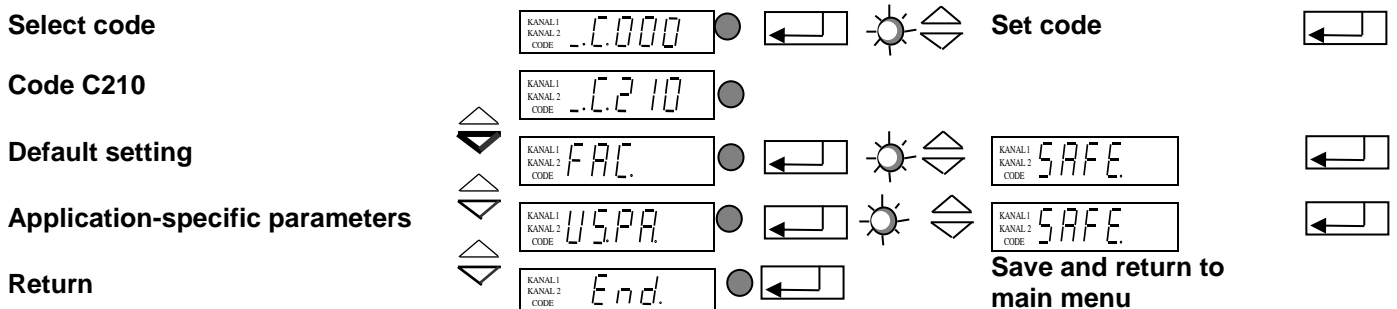

**FAC** Select and acknowledge FAC to apply the factory default settings



**US.PA.** Select and acknowledge US.PA to retrieve the application-specific set of parameters previously saved under C143.

## 6. Dimensioned drawing

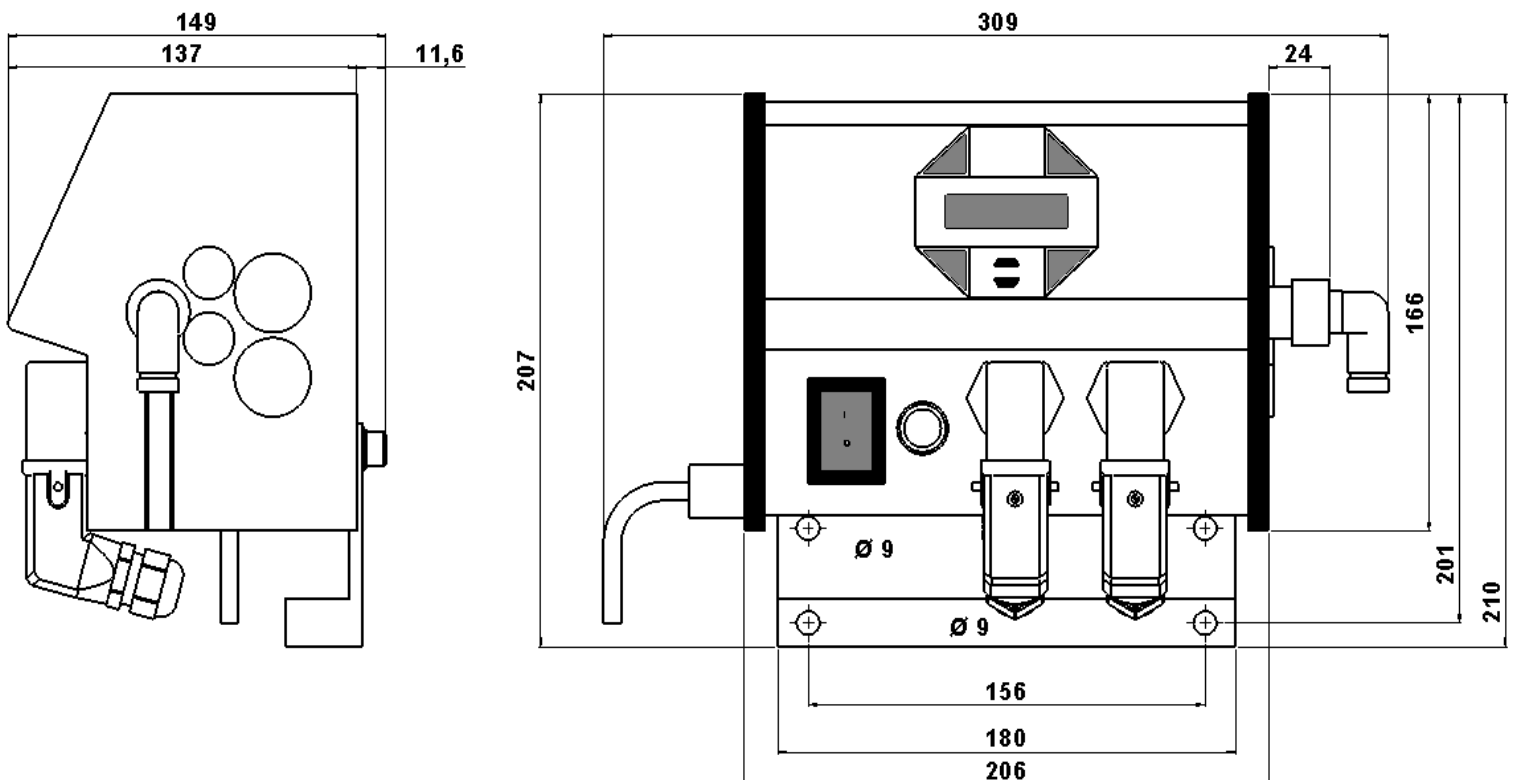





*RNA Group*

*Headquarters*

*Manufacturing and Sales*

Rhein-Nadel Automation GmbH  
Reichsweg 19-23  
D-52068 Aachen

Phone: +49 (0) 241-5109-0

Fax: +49 (0) 241-5109-219

E-Mail: [vertrieb@RNA.de](mailto:vertrieb@RNA.de)

[www.RNA.de](http://www.RNA.de)

*Further RNA group companies:*



*Manufacturing and Sales*

*Focus: Pharmaceutical Industry*

PSA Zuführtechnik GmbH

Dr.-Jakob-Berlinger-Weg 1

D-74523 Schwäbisch Hall

Phone: +49 (0) 791 9460098-0

Fax: +49 (0) 791 9460098-29

E-mail: [info@psa-zt.de](mailto:info@psa-zt.de)

[www.psa-zt.de](http://www.psa-zt.de)



*Manufacturing and Sales*

RNA Automation Ltd.

Unit C

Castle Bromwich Business Park

Tameside Drive

Birmingham B35 7AG

United Kingdom

Phone: +44 (0) 121 749-2566

Fax: +44 (0) 121 749-6217

E-mail: [RNA@RNA-uk.com](mailto:RNA@RNA-uk.com)

[www.rnaautomation.com](http://www.rnaautomation.com)



*Manufacturing and Sales*

HSH Handling Systems AG

Wangenstr. 96

CH-3360 Herzogenbuchsee

Switzerland

Phone: +41 (0) 62 956 10-00

Fax: +41 (0) 62 956 10-10

E-mail: [info@handling-systems.ch](mailto:info@handling-systems.ch)

[www.handling-systems.ch](http://www.handling-systems.ch)



*Manufacturing and Sales*

Pol. Ind. Famades c/Energia 23

E-08940 Cornellà de Llobregat (Barcelona)

Spain

Phone: +34 (0)93 377-7300

Fax: +34 93 377-6752

E-mail: [info@vibrant-RNA.com](mailto:info@vibrant-RNA.com)

[www.vibrant-RNA.com](http://www.vibrant-RNA.com)

[www.vibrant.es](http://www.vibrant.es)

*Further manufacturing sites  
of the RNA Group*

*Manufacturing  
Lüdenscheid branch*

Rhein-Nadel Automation GmbH

Nottebohmstraße 57

D-58511 Lüdenscheid

Phone: +49 (0) 2351 41744

Fax: +49 (0) 2351 45582

E-mail: [werk.luedenscheid@RNA.de](mailto:werk.luedenscheid@RNA.de)

*Manufacturing  
Ergolding branch*

Rhein-Nadel Automation GmbH

Ahornstraße 122

D-84030 Ergolding

Phone: +49 (0) 871 72812

Fax: +49 (0) 871 77131

E-mail: [werk.ergolding@RNA.de](mailto:werk.ergolding@RNA.de)

*Manufacturing  
Remchingen branch*

Rhein-Nadel Automation GmbH

Im Hölderle 3

D – 75196 Remchingen-Wilferdingen

Phone: +49 (0) 7232 - 7355 558

E-mail: [werk.remchingen@RNA.de](mailto:werk.remchingen@RNA.de)