

## VariFeed™

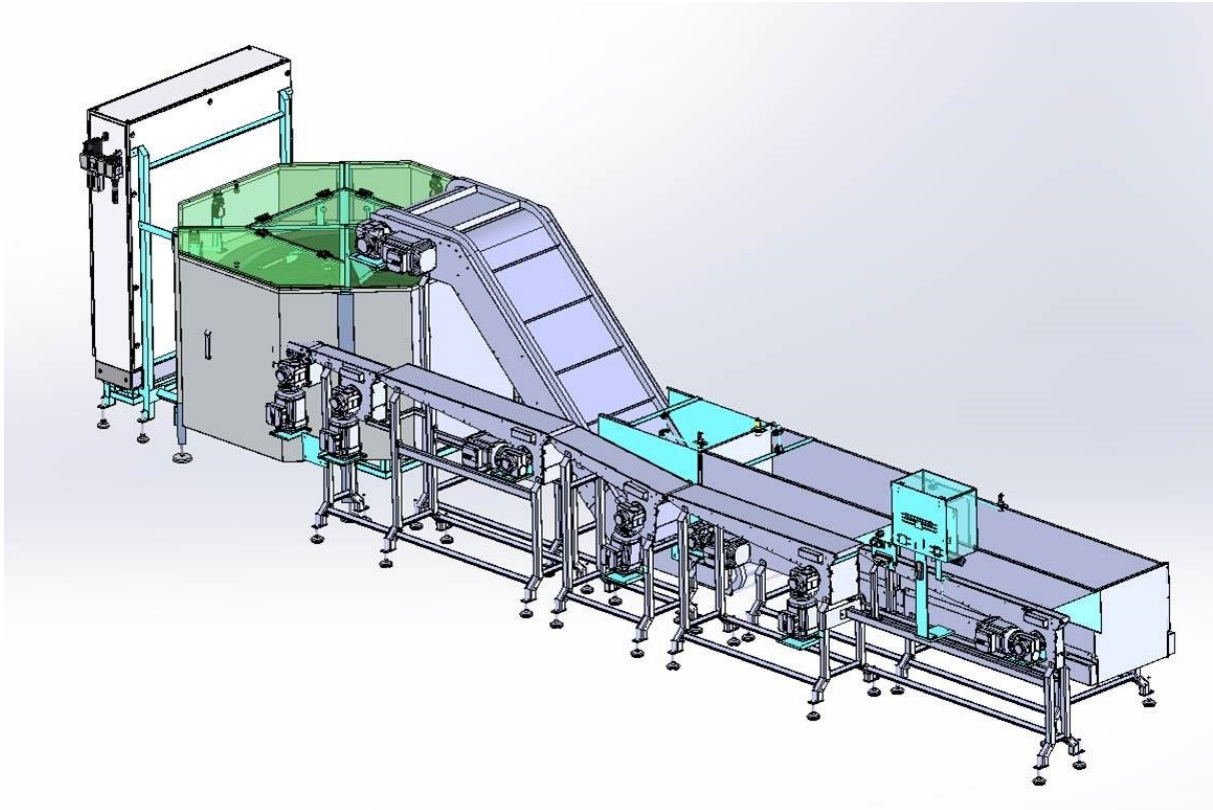

RNA's VariFeed™ is a high-speed, automated feeding system for handling chocolate and cereal bars. Up to 400 products per minute can be sorted for the subsequent packaging process. Meeting high food grade standards, the modular system can be designed for multiple products and customer layouts.

- **High-speed feeding**

The VariFeed™ is designed to run effortlessly at output rates up to 400 parts per minute.

- **Smooth and gentle handling**

The VariFeed™ offers a smooth and gentle operation which eliminates product damage. A standard platform which offers versatility, gentle handling and low noise to meet modern factory standards.

- **Scalable and modular design**

The VariFeed™ provides the flexibility to handle range of different products; The modular design allows for easy configuration to suit customer's requirements.

- **High food grade standards**

The VariFeed™ features a robust frame of stainless steel and FDA approved materials; Designed and built to meet relevant food safety standards.

## Features

- Specifically designed for food packaging industry
- Product transportation via downstream conveyor systems to subsequent packaging operations
- Various hopper size
- Various centrifugal feeder size
- Integrated high performance vision systems
- High food grade standards

## Benefits

- High feed speeds up to 400 parts per minute
- Flexible multi part handling with easy changeover
- Quiet and gentle parts handling
- Simple modular design
- Low maintenance and reliable

## Included in VariFeed™

- RNA Bulk Hopper (depending on application)
- Bowl Feeder/Centrifugal Feeder
- Conveyor transfer system (depending on application)
- PLC Control System (Siemens)

## VariFeed™

SPECIFICATION	
Product Type	Wrapped chocolate bars, Cereal Bars, Energy Bars, Fruit Bars
Hopper	Various hopper sizes to suit your application
Feeder	Vibratory bowl feeder / centrifugal feeder to suit your application
Conveyor Out-feed	Project-specific outfeeds
Recirculation	Product rejection, project-specific
Contact Material	Anodized aluminium / stainless steel / FDA approved on request (e.g. pharmaceuticals, food)
OPTIONS	
Vision Integration	Orientation station Code reading Quality control
Control System	Software upgrade / integrate to customer's ERP system

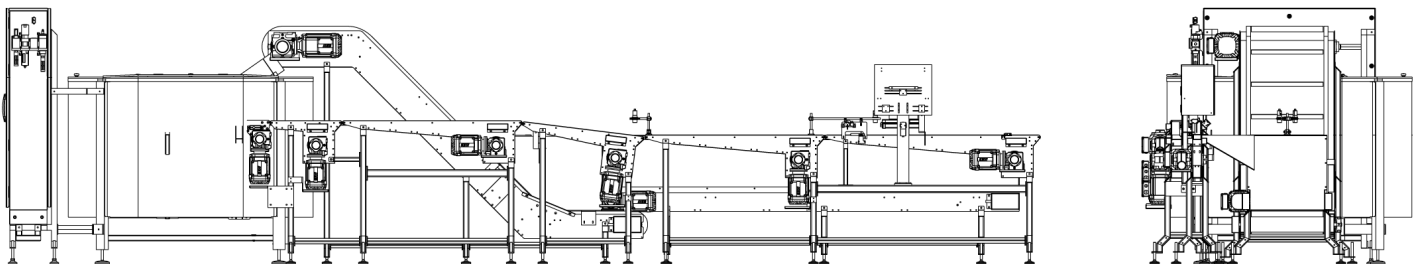
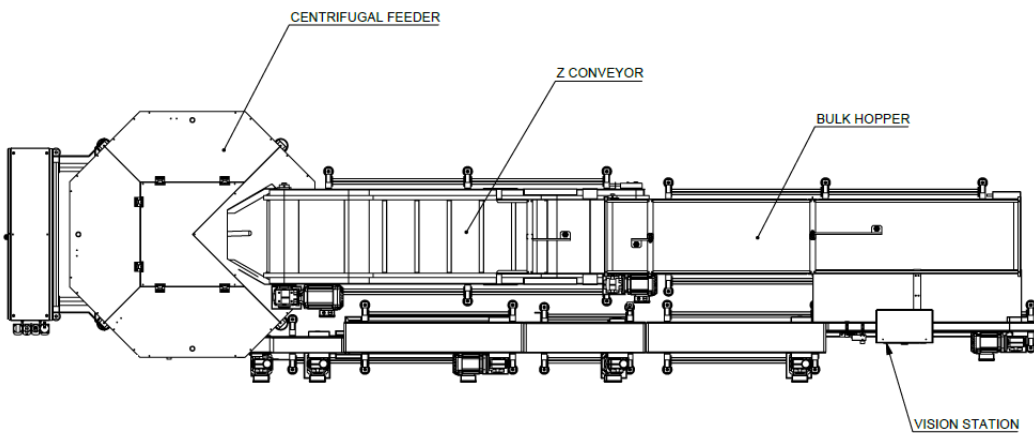

RNA Automation Ltd  
 Unit C Castle Bromwich Business Park, Tameside Drive, Birmingham B35 7AG, UK  
 Tel: +44 (0)121 749 2566 • Fax: +44 (0)121 749 6217  
 Email: sales@rnaautomation.com • Web: www.rnaautomation.com