

Operating Instructions

Controller
for vibratory drive systems

ESK 2000

Table of Contents

1.	About this document	4
2.	Safety directives.....	4
2.1.	Design of safety directives	4
2.2.	Fundamental safety directives	4
2.3.	Personnel.....	4
2.4.	Intended use	5
2.5.	Residual hazards	5
2.5.1.	Device	5
2.5.2.	Protection of the drive system	5
2.5.3.	Degree of protection - Protection of persons and equipment	5
3.	Product information	6
3.1.	Characteristic features	6
3.2.	EC conformity	6
3.3.	Technical data.....	6
3.4.	Accessories	7
4.	Notes on start-up.....	7
4.1.	Modes of operation	7
4.2.	Automatic mode change	8
4.3.	Sensor inputs and sensor linkages	8
4.4.	Sensor connection	9
4.5.	Status outputs and relays	10
5.	Operation	10
5.1.	General.....	10
5.2.	Starting-up the controller.....	11
5.3.	Main menu / Setpoint entry and display	11
5.4.	Description of individual codes for controller programming.....	12
5.5.	Application-specific change of default settings	13
5.5.1.	Code C001 feed rate output	13
5.5.2.	Code C003 Seal setpoint	13
5.5.3.	Code C004 sensor input 1 and code C005 sensor input 2	13
5.5.4.	Code C006 Sensor linkage.....	14
5.5.5.	Code C008 cycle monitoring	15
5.5.6.	Code C009 Show status.....	15
5.5.7.	Code C200 Inhibiting all code entries.....	16
5.5.8.	Code C100 Setting the feed rate by external voltage input.	16
5.5.9.	Code C143 Saving parameters	16
5.5.10.	Code C210 Retrieving parameters.....	17
6.	Dimensioned drawing.....	18
7.	Connection diagram	19



Declaration of Conformity

According to the Low-Voltage Directive 2014/35/EU
and Electromagnetic Compatibility Directive 2014/30/EU

We hereby declare that the product meets the following requirements:

Applied harmonised standards:	Low-Voltage Directive 2014/35/EC
	Electromagnetic Compatibility Directive 2014/30/EU
	DIN EN 60204 T1
	EN 61439-1

Note:

Rhein-Nadel-Automation

Managing Director
Jack Grevenstein



1. About this document



Attention

Read this document carefully and observe the safety directives before commencing any work.

Document description:

This document provides assistance in choosing your product. You will also find information on mechanical and electrical installation, operation, product extensions and accessories.

Non-observance may cause trouble with the product or the environment, reduce the product lifetime or lead to other damage.

2. Safety directives

2.1. Design of safety directives



Notice

This notice identifies useful tips for use of the controller.



Attention!

This symbol identifies hazardous situations.

Non-observance of such warnings may cause irreversible injury or even death!

2.2. Fundamental safety directives

Non-observance of the following fundamental safety measures and directives may lead to severe injury and damage to property!

Meeting the requirements given in the related documentation is a precondition for safe and trouble-free operation and for achieving the product properties specified. Further additional safety directives in the other sections must be observed as well.

2.3. Personnel



Attention!

Any work on electrical equipment of the machine/system shall be carried out exclusively by a professional electrician, or by instructed persons working under the direction and supervision of a professional electrician, according to electrotechnical rules.

Only qualified professionals are allowed to work on or with the product. IEC 60364 or CENELEC HD 384 define the qualification of these persons:

- They are familiar with set-up, installation, commissioning and operation of the product.
- They possess the qualification required for performance of their work.
- They know all regulations for the prevention of accidents, directives and laws applicable to set-up, installation and commissioning on site, and they are able to apply the same.
- They have knowledge and skills of First Aid.

2.4. Intended use

Please observe the following directives for intended use of the controllers:

- The devices herein described must only be stored, fitted and operated under the conditions specified in this documentation.
- Here you are not concerned with domestic devices! They are solely intended to be used as components for commercial or professional applications pursuant to EN 61000-3-2.
- They satisfy the protection requirements of 2014/35/EU: Low Voltage Directive.
- They do not constitute a machine as defined by 2006/42/EU: Machinery Directive.
- A machine comprising the product must not be commissioned or put into operation for the intended use until it has been declared to be in conformity with the EC Directive 2006/42/EU: Machinery Directive; Observe EN 60204-1.
- Commissioning or starting operation for the intended use is only permitted in compliance with the EMC Directive 2014/30/EU.
- Use of the product in living areas may lead to EMC disturbance. The user is responsible for taking interference suppression measures.
- They are optimised for operation of RNA bowl feeders and linear feeders. Observe the limits indicated in the technical specification.

Attention!





- Prior to start-up make sure that the protective earth conductor is connected and in proper condition. Make the PE conductor test with approved test devices only.
- Never start up despite detected damage.
- Do not make any technical modifications to the device, except as described in this document.
- Never start up in an incompletely installed state.
- Never operate the device without the required guards in place.
- Connect, disconnect or change any electrical connections only in the absence of voltage.

2.5. Residual hazards

Residual hazards may remain even if all directives have been observed and protective measures taken. Such residual hazards must be considered by the user in the risk assessment of his machine/equipment. Non-observance may lead to severe injury and damage to property!

2.5.1. Device

Pay attention to the warning signs fitted to the device!

Symbol	Description
	Hazardous voltage: Prior to commencing any work on the product check for absence of voltage on all power connections.
	Leakage current: Make fixed installation and PE connection according to EN 60204-1!

2.5.2. Protection of the drive system

Certain device parameter settings may overheat the connected drive magnet, e.g., by prolonged operation with the wrong voltage set.

2.5.3. Degree of protection - Protection of persons and equipment

- All specifications relate to installed condition ready for operation.
- All slots not used must be closed by protection caps or dummy plugs in order not to reduce the protection against accidental contact.

3. Product information

3.1. Characteristic features

The compact controller is designed for operation of a vibratory or belt feeder drive system.

The unit offers the following characteristic features:

- One feed rate output: Bowl feeder, linear feeder max. 10A, variable or AC capacitor motor max. 3A, not variable
- Two sensor amplifiers with independently adjustable timers (On/Off delay).
- External enabling input, 24 VDC
- Two relay outputs and two optocouplers for status messages and other links.
- Membrane keypad for setting and changing the operating parameters in the set-up menus.
- Plug-type connections for
 - Vibratory or belt feeder drive
 - Sensors
 - Communication with higher-level controller
- Bipolar main disconnect switch.

3.2. EC conformity

The controller is compliant with the following standards:

EC EMC Directive 2014/35/EU
EC Low-Voltage Directive 2014/30/EU

Applied harmonised standards:

DIN EN 60204, part 1
EN 61439-1

The controller is also available in a UL/CSA compliant version.

3.3. Technical data

Supply voltage:	230 V AC, 50/60 Hz, +20 / -15% 115 V AC, 50/60 Hz, +10 / -10%
Output voltage:	0 ... 208Veff; (230VAC in motor mode) at 230V supply voltage; 0 ... 98Veff; (115VAC in motor mode) at 115V supply voltage
Load current:	10 Aeff., in motor mode 3A
Minimum load current:	80 mA
Internal fusing:	F1 = 10AmT
Soft start delay, soft stop delay:	0 ... 5 sec. separately selectable
External setpoint:	0 ... 10V DC
Sensor inputs:	2
Enabling input:	24V DC (10-24VDC)
Sensor supply:	24V DC, max. 60 mA (per sensor input)
Sensor ON delay:	0 ... 60 sec. separately adjustable
Sensor OFF delay:	0 ... 60 sec. separately adjustable
Outputs:	2 relays (max. 6A 250VAC) 2 floating changeover contacts 2 normally-open contacts carrying supply voltage
2 status outputs (optocoupler):	2 optocouplers, max. 30VDC 10mA,
Ambient temperature:	0 ... 50° C
Cooling:	Free convection
Mounting:	Vibration-free
Degree of protection:	IP54

3.4. Accessories

Tag	Designation	Type	RNA part No.:
XS1	Load connector	5-pin	31002322 (100Hz drive)
XS1	Load connector	5-pin	31002322 (50Hz drive)
XS3	Coupling plug	5-pin, straight	35051144
XS3	Coupling plug	5-pin, angular	35002546
XS4	Coupling socket	7-pin, straight	35051153
XS4	Coupling socket	7-pin, angular	35002545
For XS3	Y adapter		39905940

4. Notes on start-up

Attention:

Make sure that following points are checked prior to making connection to power supply and switching on the controller:



- Is the controller casing properly closed with all screws tightened?
- Are all plug hooks engaged / firmly screwed in place?
- Are all cables and glands in proper condition?
- Is operation for the INTENDED USE made sure?
- Does the supply voltage specified on the controller match the local supply system?
- Does the supply frequency specified on the vibratory drive match the local supply system?
- Is the correct mode set on the controller? (See description under "Modes of Operation")

Only if you can clearly answer all the above questions with "Yes" should the controller be put into operation.



Attention:

Set the controller to minimum output before switching-on for commissioning or start-up after repairs or replacement of controllers/vibratory drives. Then watch proper operation while the output is increased.

4.1. Modes of operation

RNA vibratory drive systems employ mechanical spring vibrators which are set to a vibrating frequency near the mains frequency or near double mains frequency depending on weight and/or size.

This is why two modes of operation are possible:

- Mode 1: Asymmetric half-wave mode:
The vibrating drive at mains frequency.
- Mode 2: Symmetric full-wave mode:
The vibrating drive operates at double mains frequency.

To assist the operator the cable glands on the drive connector are colour-coded.

- Mode 1: black
Mode 2: Grey

In terms of the vibrating frequency this means:

	Mains frequency 50 Hz	Mains frequency 60 Hz	Cable gland colour
Mode 1 Half-wave mode	Vibration frequency 50 Hz \triangleq 3000 min ⁻¹	Vibration frequency 60 Hz \triangleq 3600 min ⁻¹	black
Mode 2 Full-wave mode	Vibration frequency 100 Hz \triangleq 6000 min ⁻¹	Vibration frequency 120 Hz \triangleq 7200 min ⁻¹	grey

4.2. Automatic mode change

Vibratory drive systems by RNA do not require the operator to take care of selecting the right operating mode. The operating mode is determined by a code in the RNA vibrating drive connector. A wire jumper from pin 3 to 4 in the connector switches the controller to mode 2: 100 or 120 Hz. In the absence of this wire jumper the controller operates in mode 1: 50 or 60 Hz.

The RNA vibratory drive systems come with the right code in the connector.

A mode change is made only and exclusively via the code in the vibrating drive connector.

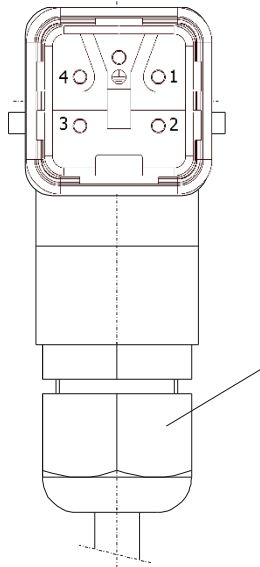

M20 gland

Black: 50/60Hz vibrating frequency
Grey: 100/120Hz vibrating frequency
(EMC metal gland if frequency controllers are used.)

(Where frequency controllers with selectable output frequency are used, an EMC metal gland and a shielded cable are provided.)

4.3. Sensor inputs and sensor linkages

The controller has two sensor inputs which are used for accumulation checking, level checking, cycle monitoring and other monitoring functions. The following basic assignments are made: Sensor input 1 acts on channel 1, unless otherwise programmed in menu C006. Sensor input 2 is provided for additional functions, see sensor linkage. The sensor inputs can be evaluated only if they are activated in codes C004, C005. For sensor connection (connector XS3) please refer to the connection diagram.

4.4. Sensor connection

The controller has two sensor inputs which can be used for accumulation checking and/or level monitoring purposes. You can connect sensors of type NPN or PNP.

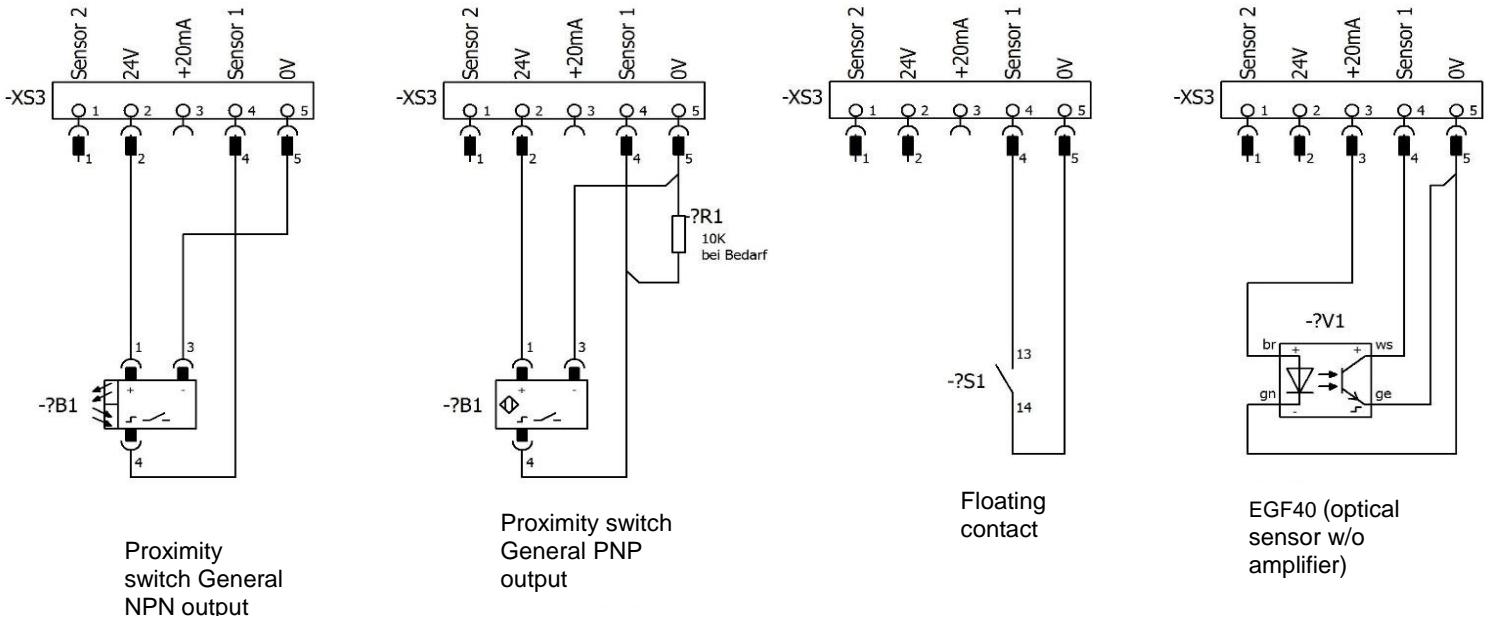

PNP switching sensors may require a 10K resistor between sensor output and 0V.

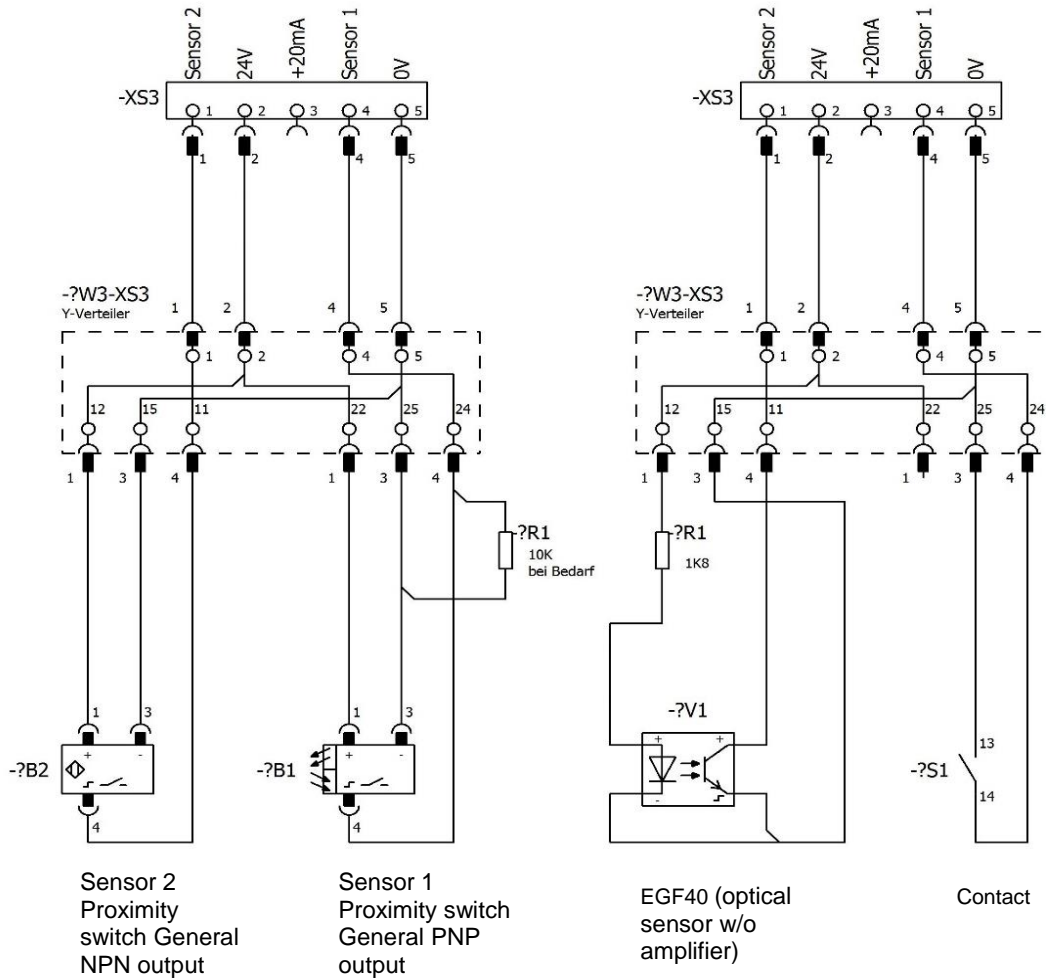

Connection of 2 sensors via Y adapter

4.5. Status outputs and relays

The status outputs are used for remote diagnostics of the controller status or of the links of several controllers with one another. They are designed as freely available NPN-doped transistor circuits and they are floating.

With the status output **READY** the transistor circuit is switched through whenever the controller is connected to power supply and switched on by its power switch closed.

The status output **ACTIVE** requires the same conditions for switching-through as "READY". In addition, channel 1 must be operating actively, the transistor blocks in case of ACCUMULATION, OFF or STOP.

The status outputs and inputs as well as the external enabling input are to be wired via plug connector XS4.

The two relays have different functions. K1 operates as a status relay parallel to the **ACTIVE** status output. K2 serves either for a blowing air switch-off delay (4 sec.) or for cycle monitoring of one of the two sensor channels.

Connections and cable entry are on the right-hand side of the controller with the terminal block behind the panel.

5. Operation

5.1. General

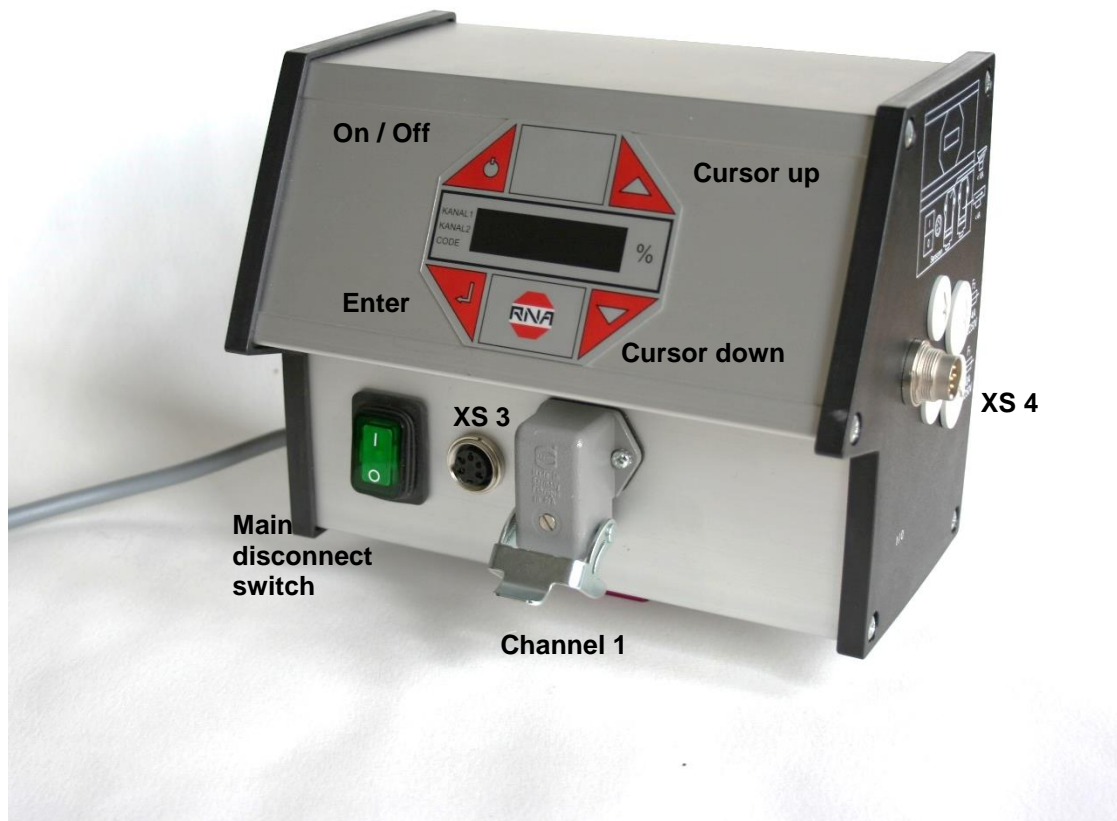

Controller plug connections

Main disconnect switch

Double-pole isolation of the controller from power supply

XS 3

Connector for sensors

Channel 1 (XS1)

Connector for bowl feeder or linear feeder or motor (<10A)

XS 4

Connector for optocoupler outputs and external enabling input

The controller display (membrane keypad)



On / Off

Pressing this button switches off all connected devices. The display shows "OFF". The controller remains ready for operation.



Cursor up and cursor down

Use these buttons to scroll through the controller menu or set the parameters.



Enter

Press this button to acknowledge the parameters entered with the cursor.



Decimal point in the display

The decimal point is not blinking. You cannot make any entry.



The decimal point is blinking, an entry can be made.

5.2. Starting-up the controller

To start up the controller, close the main disconnect switch. The main menu appears on the display showing the last setpoint entered (feed rate of the vibratory feeder or linear feeder).

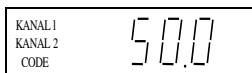

Alternatively, the following may appear on the display depending on the switching status of the device:

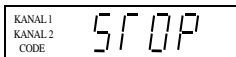

External enabling signal has been activated but it is withdrawn from the device at the moment. (medium priority)

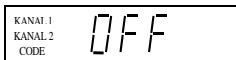

Device has been switched off by operating the top left button of the membrane keypad, inhibiting all functions. (high priority)

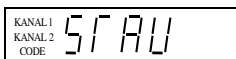

The accumulation monitoring sensor is operated, switching off the vibratory drive. (low priority)

5.3. Main menu / Setpoint entry and display

Display of setpoint or feed rate (vibratory feeder)

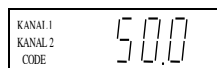

No entry possible

Alternatively: STOP, OFF or ACCUMULATION (see above)



Entry of the codes to change or execute the required settings.

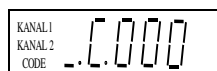

Enter code.

Description of codes see under 4.4.



Setpoint entry for channel 1 (bowl feeder or linear feeder)

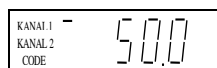

Entry in %; return to display mode for saving



From these three basic screens of the main menu you can scroll in the main menu using the cursor buttons (UP/DOWN). In each individual item of the main menu you can press ENTER to activate this item for setting or changing. Upon pressing of the ENTER button the decimal point starts blinking. Now you can make changes using the cursor buttons (UP/DOWN). Press ENTER again to acknowledge the entries made. The decimal point is no longer blinking. Using the cursor buttons you can continue scrolling in the menu. Same procedure analogously applies to the code menus described below.

All the following display screens show the default setting. If the actual display on the controller differs the default setting has been changed in individual codes to suit a specific application.

5.4. Description of individual codes for controller programming.

KANAL 1
KANAL 2
CODE ..C.001

Settings for channel 1

In this sub-menu you can set or limit the following functions for channel 1:

- Vibrating amplitude
- External enabling, signal direction of external enabling input
- Soft start and stop delay
- Selection of vibratory or belt feeder drive

KANAL 1
KANAL 2
CODE ..C.003

Sealing a setpoint

In this sub-menu you can lock the setpoints (vibrating amplitude) of the main menu. It is no longer possible to change the setpoints for channel 1 in the main menu. This avoids accidental changes to performance parameters. You can only make any changes now through code C001.

KANAL 1
KANAL 2
CODE ..C.004

Setting the sensor input 1

This is the sub-menu for activation of sensor input 1. In addition you can set the following functions:

- Invert input signal direction
- Start delay
- Stop delay

KANAL 1
KANAL 2
CODE ..C.005

Setting the sensor input 2

This is the sub-menu for activation of sensor input 2. In addition you can set the following functions:

- Invert input signal direction
- Start delay
- Stop delay

KANAL 1
KANAL 2
CODE ..C.006

Choosing the sensor links

In this sub-menu you can link the sensors activated by codes C004 and C005 with one another.

KANAL 1
KANAL 2
CODE ..C.008

Setting the cycle watchdog

Here you can set which sensor input is to be monitored and how the controller is to react to an error.

KANAL 1
KANAL 2
CODE ..C.009

Show status

This sub-menu serves for checking of the set vibrating frequency and of the sensor inputs.

KANAL 1
KANAL 2
CODE ..C.010

Calling-up the software version

Definition: 411. 57. 10. 23.11.99

→	Date	59 = ESK 2001
→	Version No.	58 = ESG 2001
→	Device type	57 = ESK 2000
→	Internal No.	56 = ESG 2000

KANAL 1
KANAL 2
CODE ..C.100

Setting the feed rate by external voltage input 0-10V or potentiometer

KANAL 1
KANAL 2
CODE ..C.143

Saving parameters

You can save the (application-specific) settings previously made in various sub-menus under code 143.

KANAL 1
KANAL 2
CODE ..C.200

Inhibiting all setting functions

With the aid of this code you can disable all input facilities of the controller. It is no longer possible to change any values. The only way now to enable the menu again is through this code.

KANAL 1
KANAL 2
CODE ..C.210

Retrieving parameters

Inn this sub-menu you can return the controller to the default settings. You can also return to application-specific settings, if previously saved.

5.5. Application-specific change of default settings

5.5.1. Code C001 feed rate output

Objective: Setting and limiting the vibration amplitude, external enabling, soft start delay and soft stop delay.

Select code			Set code	
Code C001				
Set vibrating amplitude			0 - 100 %	
Limit vibrating amplitude			50 - 100 % (*)	
External enabling			1 = active 0 = not active	
External enabling signal direction			1 = Start = 24V DC 0 = Stop = 24V DC	
Soft start delay			0 - 5 sec.	
Soft stop delay			0 - 5 sec.	
Switching to vibratory or belt feeder drive			0 = vibratory drive 1 = belt drive	
Return			Save and return to main menu	

(*) For RNA feeders with 200 V magnets = 90 %

5.5.2. Code C003 Seal setpoint

Objective: Sealing-in the setpoints in the main menu. A direct change of the values is no longer possible. You can only make changes now through code C001.

Select code			Set code	
Code C003				
Setpoint (vibrating amplitude)			1 = adjustable 0 = input inhibited	
Return			Save and return to main menu	

5.5.3. Code C004 sensor input 1 and code C005 sensor input 2

Objective: Activating and setting the sensor inputs

Select code			Set code	
Code C004				
Sensor 1 input			1 = active 0 = not active	
Invert input signal direction			1 = Start = 24V DC 0 = Stop = 24V DC	
Delay of sensor status CLEAR, Start delay			0 - 60 sec.	
Delay of sensor status OPERATED, Stop delay.			0 - 60 sec.	
Return			Save and return to main menu	

Same applies analogously to code **C005** (sensor input 2).

5.5.4. Code C006 Sensor linkage

Objective: Linking of the two previously activated sensor inputs.

Select code

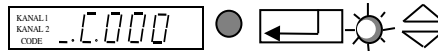

Set code



Code C006

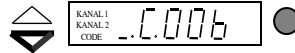

You can activate only one of the eight sensor links.

AND logic with blowing-off the exit tracks

AND logic without blowing-off the exit tracks (from version No. 10)

OR logic

Min/Max logic

AND / S2 logic (from version No. 10)

Level check with external control

Level check indicator light

Individual link

Return

					I = active	
					0 = not active	
					I = active	
					0 = not active	
					I = active	
					0 = not active	
					I = active	
					0 = not active	
					Save and return to main menu	

Brief description of individual links

AND logic of the two sensor inputs with blowing-off the exit tracks.
Example:

Application: Twin-track feeders with accumulation checker.

Solution: Track 1 (sensor 1) full = Blow-off track 1 (relay K1)

Track 2 still clear

Track 2 (sensor 2) full = Blow-off track 2 (relay K2)

Track 1 still clear

Track 1 + Track 2 full = Bowl feeder (channel 1) Stop about 4 sec. later blowing air stop

AND logic of the two sensor inputs without blowing-off the exit track. Bowl feeder (channel 1) stops when both sensors are operated. Orienting air can be switched off with delay (4 sec.) via relay K2.

OR logic of the two sensor inputs. Bowl feeder (channel 1) stops when one of the two sensors is operated. Orienting air can be switched off with delay (4 sec.) via relay K2.

Min/Max logic of the two sensor inputs. The bowl feeder stops when **both** sensors are operated. The vibratory feeder (channel 1) will re-start only after **both** sensors are cleared again. Relay K1 operates on stopping of bowl feeder. Relay K2 operates 4 sec. later (stopping the blowing air)

AND / S2 logic Bowl feeder (channel 1) stops when both sensors are operated. It starts when sensor 2 is cleared again. Orienting air can be switched off with delay (4 sec.) via relay K2.

Level check for hoppers with external hopper control Sensor 2 operates relay K1 following the delay period entered (C005). When sensor 1 is operated, relay K1 drops out (hopper interlock).

Application: Sensor 1 = accumulation check;
Sensor 2 = level check;
Relay K1 = hopper control



Level check with indicator light

Sensor 2 operates relay K1 following the delay period entered (C005).

Application: Sensor 2 is used as a level checker (e.g., LC-N 24V DC). Relay K1 operates an indicator light: *Bowl feeder or linear feeder empty*.

5.5.5. Code C008 cycle monitoring

Objective: Monitoring of sensors 1 (accumulation check) and/or 2.

When activating the cycle monitoring function, the "AND, SOL" links in code C006 must not be activated!!!

Select code			Set code	
Code C008				
Sensor input 1 is monitored			I = active 0 = not active	
Sensor input 2 is monitored			I = active 0 = not active	
Monitoring depending on Channel 1			I = active 0 = not active	
Time till alarm comes up			3 - 240 sec.	
Switching off channel 1			I = see below 0 = see below	
Switch			I = Alarm on relay K1 0 = Alarm on relay K2	
Return			Save and return to main menu	



The cycle watchdog monitors the CLEAR sensor status. The time (A 180) sets the maximum duration for which a sensor is allowed to be clear before an alarm message is generated.

In case of an alarm the relay K2 is clocked on and off. Reset takes place automatically when the sensor is operated again.



If OUT = 1 the alarm operates relay K2 (indicator light: Error) and also stops the bowl feeder or linear feeder. An ERROR message appears on the panel display.

Use the bottom right cursor button for reset.

If OUT = 0 the alarm only operates relay K2 (indicator light: Error). Reset takes place automatically when sensor 1 is operated.



If A.I. = 1 relay K1 is clocked on and off in response to the alarm (switching from relay K2 to relay K1).

5.5.6. Code C009 Show status

Objective: Checking of the set vibrating frequency and of the sensor inputs.

Select code			Set code	
Code C009				
External enabling signal Channel 1			I = active 0 = not active	
Channel 1 vibrating frequency			I = 50 Hz 0 = 100 Hz	
Signal at sensor input 1			I = active 0 = not active	
Signal at sensor input 2			I = active 0 = not active	
Return			Save and return to main menu	



Under menu item HA = half wave you can check whether the correct operating mode (50/60Hz or 100/120Hz) is set.

5.5.7. Code C200 Inhibiting all code entries

Objective: An (accidental) change of the set values by the user is not possible any more.

Select code					Set code	
Code C200						
Inhibiting the setting functions					I = enable 0 = disable	
Return					Save and return to main menu	

Only code C200 is accepted!!!
You can change the setpoints for channels 1 and 2 in the main menu (see under 4.3).

5.5.8. Code C100 Setting the feed rate by external voltage input.

Objective: Setpoint change by external voltage

Select code					Select code	
Code C100						
External voltage application to channel 1					I = active 0 = not active	
Return					Save and return to main menu	

If external voltage application is activated the last digital feed rate set (%) constitutes the minimum feed rate for 0 volt. Set the maximum feed rate for 10 volt by the P parameter in C001.

Connect the external voltage to terminals 31, 32 and 33 in the controller.
You find the terminals behind the right-hand side panel.
Terminal 31 = +10V
Terminal 32 = E
Terminal 33 = 0V



Attention!
Before opening the device be sure to observe the safety directives in chapter 2.

5.5.9. Code C143 Saving parameters

Objective: Saving of application-specific parameters

Select code					Select code	
Code C143						
Save						
Return					Save and return to main menu	

Having pressed ENTER to acknowledge PUSH you can save the selected parameters separately by pressing a cursor button.

5.5.10. Code C210 Retrieving parameters

Objective: Resetting to default values or retrieving stored application-specific settings

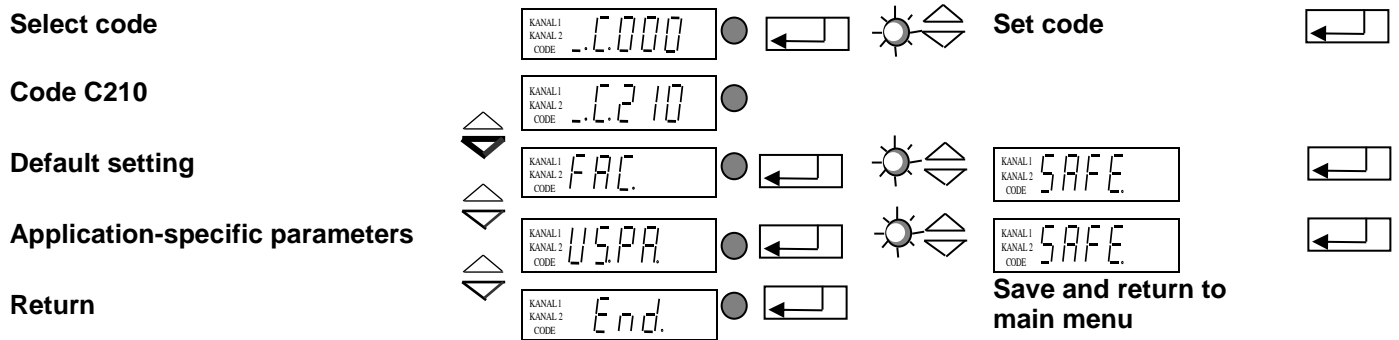

 **FAC:** Select and acknowledge FAC to reset the controller to the factory default settings.

 **US.PA.:** Select and acknowledge US.PA. to retrieve the application-specific set of parameters previously saved under C143.

6. Dimensioned drawing

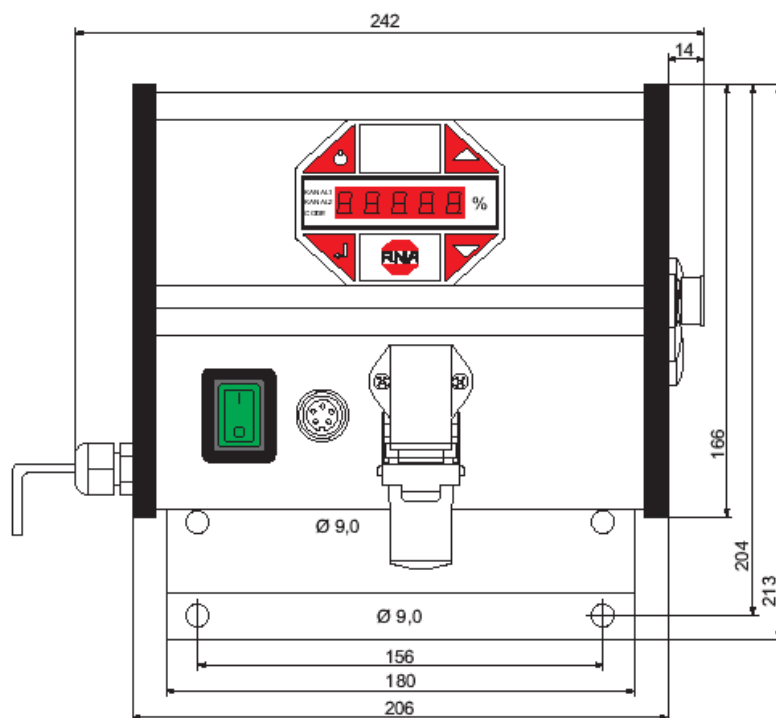
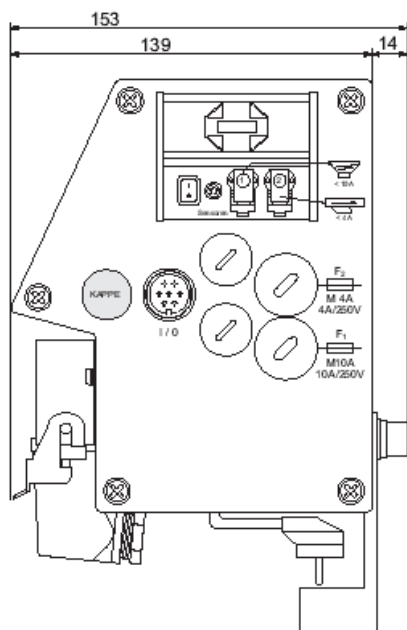

7. Connection diagram

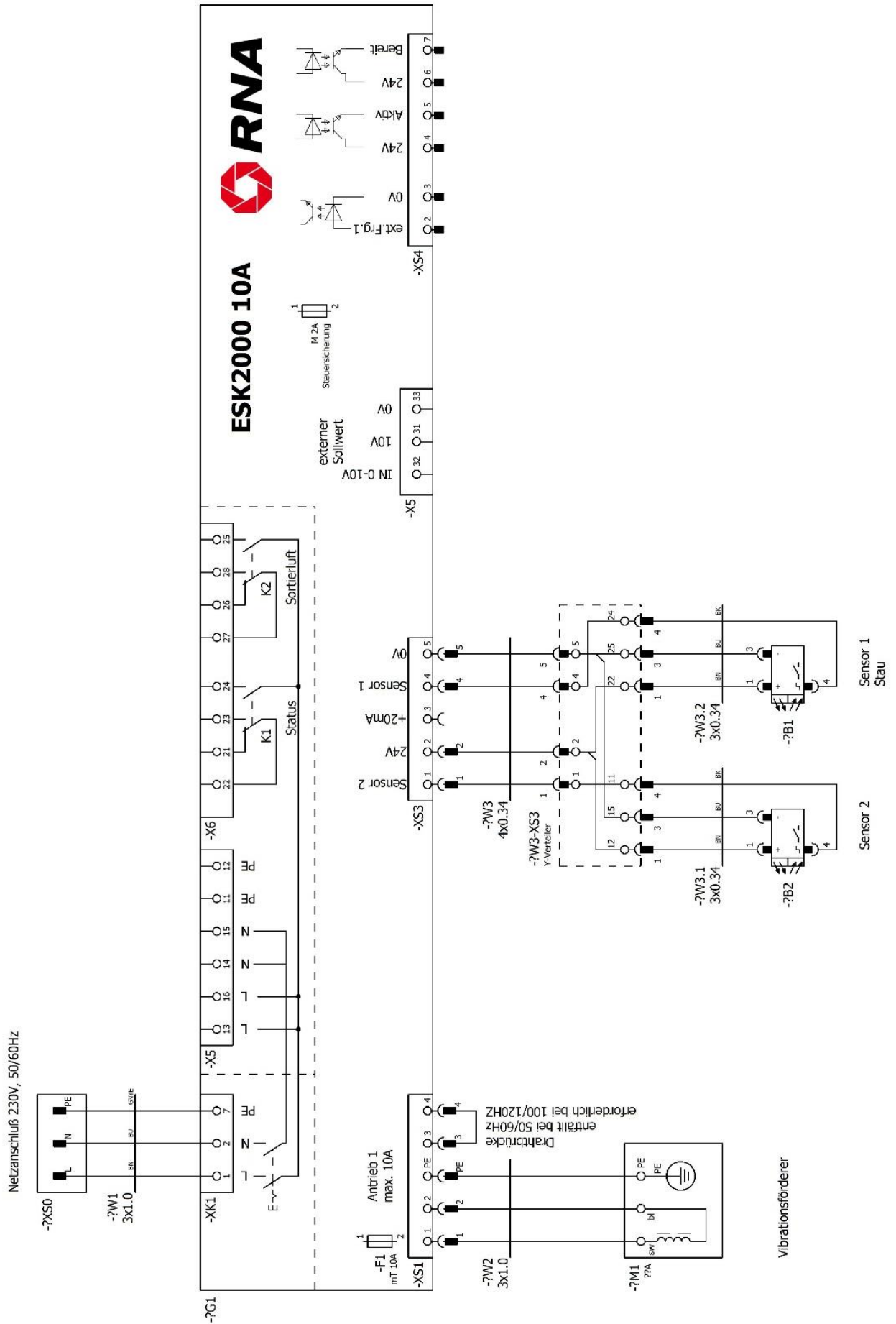



RNA Group

Headquarters

Manufacturing and Sales

Rhein-Nadel Automation GmbH
Reichsweg 19-23
D-52068 Aachen

Phone: +49 (0) 241-5109-0

E-Mail: vertrieb@RNA.de

www.RNA.de

Further RNA group companies:



Manufacturing and Sales

Focus: Pharmaceutical Industry

PSA Zuführtechnik GmbH

Dr.-Jakob-Berlinger-Weg 1

D-74523 Schwäbisch Hall

Phone: +49 (0) 791 9460098-0

Fax: +49 (0) 791 9460098-29

E-mail: info@psa-zt.de

www.psa-zt.de



Manufacturing and Sales

RNA Automation Ltd.

Unit C

Castle Bromwich Business Park

Tameside Drive

Birmingham B35 7AG

United Kingdom

Phone: +44 (0) 121 749-2566

Fax: +44 (0) 121 749-6217

E-mail: RNA@RNA-uk.com

www.rnaautomation.com



Manufacturing and Sales

HSH Handling Systems AG

Wangenstr. 96

CH-3360 Herzogenbuchsee

Switzerland

Phone: +41 (0) 62 956 10-00

Fax: +41 (0) 62 956 10-10

E-mail: info@handling-systems.ch

www.handling-systems.ch



Manufacturing and Sales

Pol. Ind. Famades c/Energia 23

E-08940 Cornellà de Llobregat (Barcelona)

Spain

Phone: +34 (0)93 377-7300

Fax: +34 93 377-6752

E-mail: info@vibrant-RNA.com

www.vibrant-RNA.com

www.vibrant.es

*Further manufacturing sites
of the RNA Group*

Manufacturing

Lüdenscheid branch

Rhein-Nadel Automation GmbH

Nottebohmstraße 57

D-58511 Lüdenscheid

Phone: +49 (0) 2351 41744

Fax: +49 (0) 2351 45582

E-mail: werk.luedenscheid@RNA.de

Produktion

Ergolding branch

Rhein-Nadel Automation GmbH

Ahornstraße 122

D-84030 Ergolding

Phone: +49 (0) 871 72812

Fax: +49 (0) 871 77131

E-mail: werk.ergolding@RNA.de