



Operating Instructions Conveyors

FP 120
FK 120

BA

Rhein-Nadel Automation GmbH

Table of contents

Chapter		Page
1	Technical data	2
1.1	Table	2
1.2	Connecting plans motors	3
2	Safety instructions	5
3	Construction and function of the conveyor belts	6
4	Transport and mounting	6
4.1	Transport	6
4.2	Mounting	7
4.2.1	One-piece conveyor belts	7
4.2.2	Mounting multi-piece conveyor belts	7
4.2.3	Mounting RNA-stands	8
4.2.4	Drive unit (conveyor belts without RNA-control units)	8
4.2.5	Preadjustment of the belt run	9
5	Starting	9
6	Maintenance	10
6.1	Belt	10
6.2	Motor	10
6.3	Gear unit	11
6.4	Chain drive	11
6.5	Deflection, drive and supporting rollers	11
6.6	Environmental influences	11
7	Stockkeeping of spare parts and after sales service	11

1 Technical data

1.1 Table

Conveyor belt lengths = distance between conveyor centers	[mm]	500...12.000
Belt widths	[mm]	50,80,100,120,150,200,250,300,400 and > 400 on request (intermediate widths possible)
Conveyor belt load at belt width ≤ 100 mm	[kg/m]	10 (max. 30 total at horizontal transport)
Conveyor belt load at belt width ≥ 100 mm	kg/m	20 (max 100 total at horizontal transport)
Material to be transported	[kg]	max. 10 or 20
Belt speed constant (Threephase current motor 230/400 V ± 10% 50 Hz, IP 54)	[m/min]	0.5, 1, 2, 3, 4, 5, 6, 7, 8, 10, 15, 20, 30, 50, 60, 80 Other speeds possible
Belt speed constant (A.C. motor 230V/50Hz, IP54) at belt width ≤ 100 mm at belt width ≤ 400 mm and belt length ≤ 2,000 mm	[m/min.]	0.5, 1, 2, 3, 4, 5, 6, 7, 8, 10, 15, 20, 30 0.5, 1 other belt speeds possible
Belt speed adjustable (frequency control) (Threephase current motor to 370W, 230V, 50Hz, IP54; threephase current motor over 370 W, 400 V, 50 Hz, IP 54)	[m/min.]	0.25...1/0.5...2/1.25...5/2.5...10/5...20/7.5...30/15...60/20...80 Other speeds possible
Belt speeds adjustable (D.C. motor 230V 50-60 Hz, IP54)	[m/min.]	0.25...1/0.5...2/1.25...5/2.5...10/5...20/7.5...30 Other speeds possible
Current consumption		See type plate
Roller diameter	[mm]	52
Tensioning station		Integrated in the deflecting station at belt lengths ≥ 5,000 mm additional central tensioning station

1.2 Connecting plans motors

1.2.1 SN3F, SN5FR, SN6F, SN8F, SN10F, SN13F

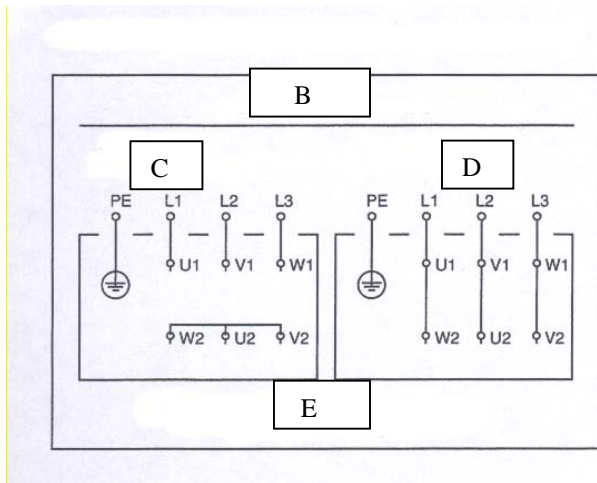

- B Connection at 3 conductors-mains
- C Star connection (high voltage)
- D Delta connection (low voltage)
- E For change of rotation, change two Phases of the lead terminal diagram

Three-phase motor

1.2.2 SN3FT, SN6FT, SN8FT, SN10FT, SN13FT

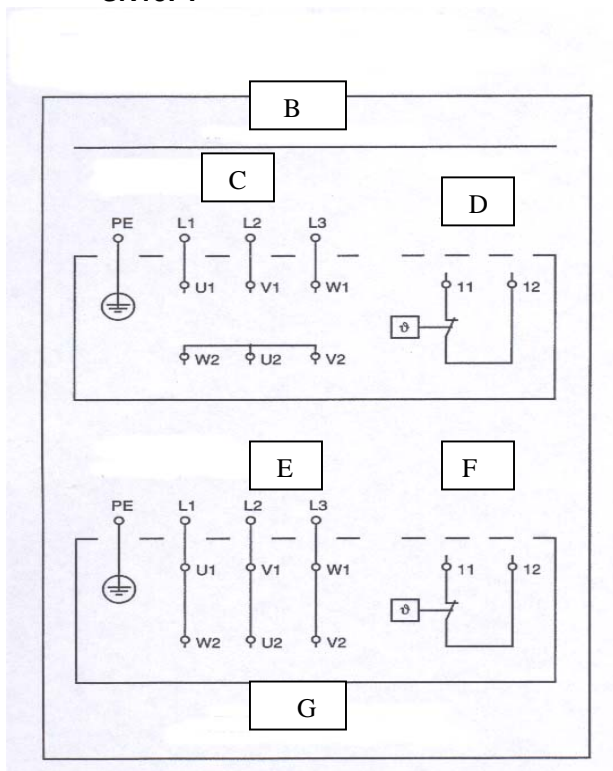

- B Connection at 3 conductors-mains
- C Star connection (high voltage)
- D earthing contact

Terminal diagram for Three-phase motor

1.2.3 SN3FBR, SN8FBR

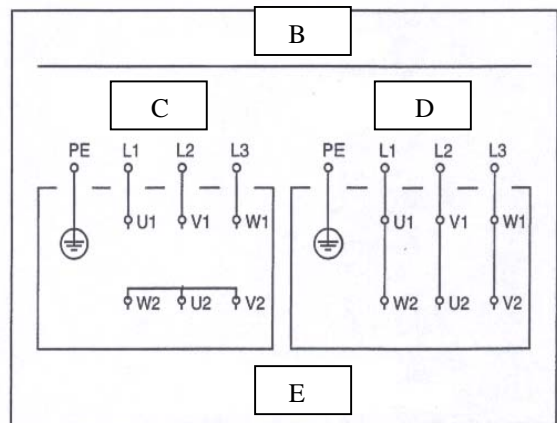

- B Connection at 3 conductors-mains
- C Star connection (high voltage)
- D Delta connection (low voltage)
- E For change of rotation, change two phases Of the lead terminal diagram

Three-phase Brake Motor

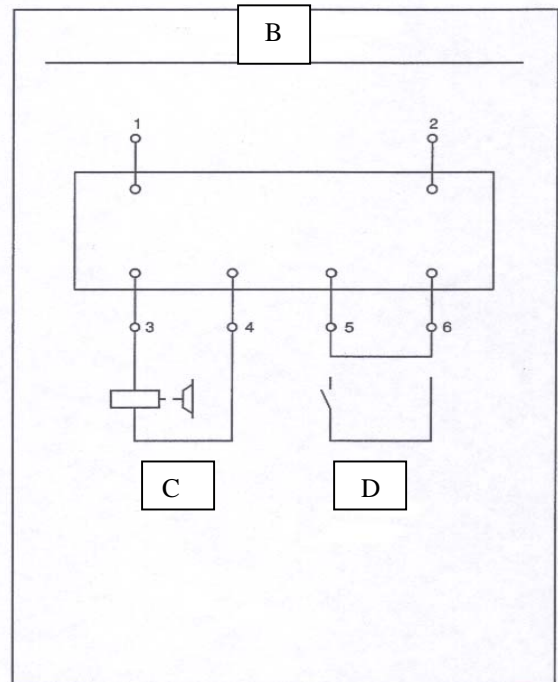

- B Connecting voltage – see type plate
- C Brake
- D Bridge or no contact

1.2.4 SN5FRBR, SN6FBR, SN10FBR, SN13FBR

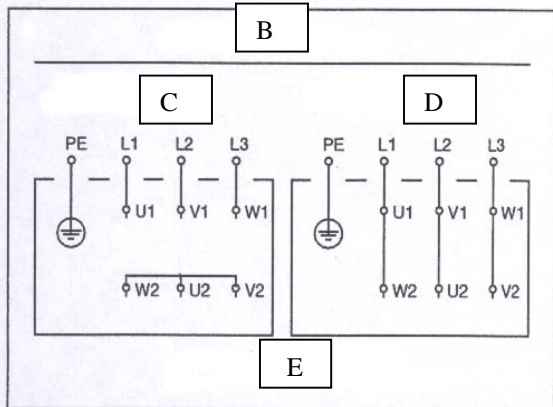

- B Connection at 2 conductors-mains
- C Star connection (high voltage)
- D Delta connection (low voltage)
- E For change of rotation, change two phases of the lead

Terminal diagram for 3 phase brake motor

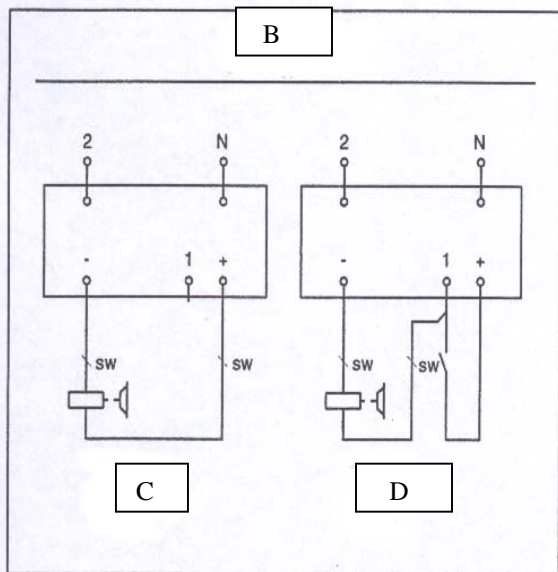

- B Connecting voltage
- C Brake AC
- D Brake OC

1.2.5 SN3FW, SN5FRW, SN6FW, SN13FW, SN18FW

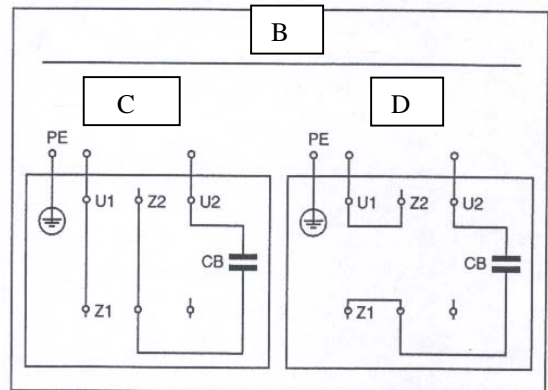

- B Connection at 2 conductor-mains
- C Counter clockwise
- D Clockwise

1.2.6 SN3FG, SN5FRG, SN6FG, SN8FG,

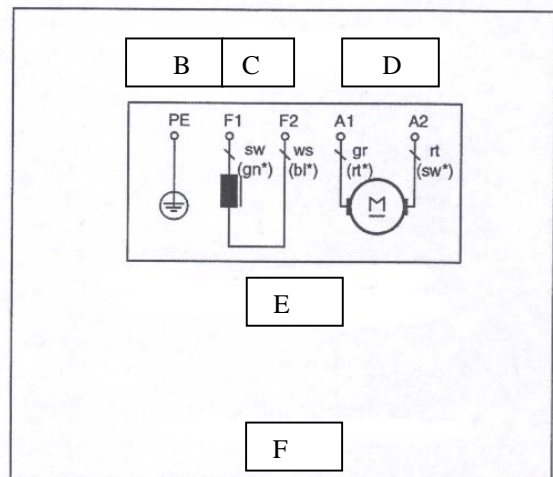

- B protective conductor
- C field winding
- D armature-circuit
- E For change of rotation change field lines F1 and F2.
- F Colours in terminals apply to SN3FG.

2 Safety instructions

The conception and production of our conveyor belts has been carried out very carefully, in order to guarantee trouble-free and save operation. You too can make an important contribution to job safety. Therefore, please read the short operating instructions completely, before starting the machine. Always observe the safety instructions!



Attention

This warning triangle marks safety instructions. Non-observance of these warnings can result in serious or fatal injuries!



Careful!

This warning triangle marks safety instructions. Non-observance of this warning can result in slight personal injuries or property damage.



Notice

This hand points to information that gives you useful tips for the operation of conveyor belts.

Make sure that all persons working with or at this machine carefully read and observe the following safety instructions!

The operating instruction is only valid for the types indicated on the front page.

It must always be available at the place of operation of the conveyor belt!

When using the conveyor belt in humid or wet environment (wet area) it has to be made sure that the required insulation type is provided.



Notice

Detailed information on the total range of control units may please be taken from the operating instructions "control units".

Starting, conversion, maintenance and repair work may only be carried out by qualified and authorized personnel (see also "requirements on the user" in this chapter).

During assembly, maintenance and repair the conveyor belt must be all-pole separated from the mains according to the VDE-regulations.

Work at the electric equipment may only be carried out by an electrician or a person trained in electrical engineering under the supervision of an electrician, according to the electronics regulations.



Attention

There is the danger of injuries and the danger of an electric shock!

- User and operator must take care that only authorized personnel works at the conveyor belt.
- The operator must immediately be informed about any changes impairing safety.
- The conveyor belt may only be operated in perfect condition!
- The conveyor belt may only be operated according to the intended use.
- Please observe the regulations for prevention of accidents VGB 4 for electric plants and equipment!

Dangers occurring at the machine

- In case the conveyor belt gets wet, there is the danger of an electric shock!
- Make sure that the protector ground of the electric power supply is in perfect condition!
- Operation of the conveyor belt without trim panels and protection hoods (chain drive) is prohibited in any case!
- The gap between the drawing-in points may not be larger than 4 mm, otherwise there is the danger of something being drawn in. In case a larger gap is caused owing to the belt adjustment, the protective collar must be readjusted.

Intended use

The intended use of conveyor belts is the transport of material.

This material to be transported must have a side length of at least 5 mm. By special designs or other equipment the conveyor belts can be retrofitted for material with smaller side length (>0.5 mm). If necessary, please turn to the manufacturer.

**Careful!**

Smaller parts may get under the belt and cause damage or failure of the conveyor belt.

When using standard belts the material to be transported must be dry, clean and without sharp edges. For the transport of sharp-edged, oily, wet or hot (>70°C) material special belts must be used.

**Careful!**

For the transport of material which could tip over, roll or slide, a sufficient number of solid lateral guiding appliances or slat belts from the accessory parts programme must be used.

The material to be transported may not fall down on the belt from a great height. The permissible maximum impact energy is 0.1 J.

In case of doubt please turn to the manufacturer.

The conveyor belts are designed for horizontal transport at maximum load. A slight inclination of the transport plane is possible in the individual case. In this case ask the manufacturer for a definite individual solution!

The permissible belt load may please be taken from the technical data (chapt. 1).

Noise emission

The constant sound level is at maximum 70 dB(A). Transporting the material or the belt condition can produce a high sound level. For these exceptional cases noise protection measures can be requested from the manufacturer.

Requirements on the user

Starting, retrofitting as well as maintenance and repair work may only be carried out by qualified and authorized professionals.

We distinguish four qualification levels:

Qualified personnel

are persons who are familiar with the assembly, mounting, starting and operation of the conveyor belt. They are qualified appropriately to their task.

Authorized personnel

is qualified personnel, who is given a clearly defined task.

Electrician

(according to IEC 364 and DIN VDE 0105 part 1) is a person who, owing to her/his specialist qualifications, knowledge and experience, as well as knowledge of the relevant standards, is able to judge and recognize the tasks given to her/him, and who can see possible dangers.

Person trained in electrical engineering

(according to IEC 364 and DIN VDE 0105 part 1) is a person who is instructed by an electrician in the tasks she/he is given. She/he is also informed on possible dangers in case of inexpert behaviour and on necessary protective equipment and measures.

3. Construction and function of the conveyor belts

The conveyor belts are made of bent section sheet metal (FK 120) or a special aluminium slot section (FP 120). For the actuation a wide range of motors for constant and controllable speed is available. The drive unit can be located either at the entry of the conveyor belt, at the end, or in the middle. Control of the conveyor belt takes place by protective motor switch, electronic control units or frequency-controlled control units, depending on the motor type.

**Notice**

Information on the control units may please be taken from the separate operating instructions "control units".



Figure 1: Construction of the conveyor belts

4. Transport and mounting

4.1 Transport

Transport ex works

The conveyor belts are delivered ex works in cardboard boxes or cases.

Transport within the plant

The weight of the conveyor belt depends on the dimensions and on the motor capacity. Please take the weight of your special design from the freight documents.



Attention

When unpacking the equipment all protective devices must be controlled. Before starting, replace all damaged parts!



Careful!

One-piece conveyor belts can be brought to their place of operation on a sufficiently solid truck. Multi-piece conveyor belts may not be transported while being mounted.

4.2 Mounting

4.2.1 One-piece conveyor belts

Conveyor belts delivered as one-piece equipments are completely mounted. Mounting them on the RNA-stands is described in chapter

4.2.2 Mounting multi-piece conveyor belts

Owing to reasons of transport and packing RNA-conveyor belts with a total length of more than 3 m are delivered in segments. Mounting of these conveyor belts is described in the following.

Mounting of the conveyor belt frame

- Put together the junction points marked with the same numbers (figure 2).

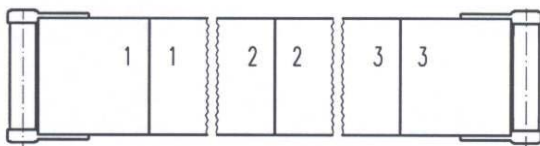

Figure 2: Putting together the individual parts

- Lift one of the outer conveyor belt frames and slide it over the next conveyor belt frame so that the total length of the conveyor belt is reduced. Now you can slide the belt laterally over the conveyor belt frame (see the following notice).



Notice

The standard belts are provided with a finger connection and are endless. At these belts the running direction can be selected as needed.

In case of belts with overlap connection the running direction should be selected according to the following figure.

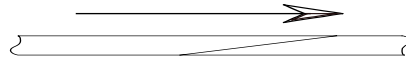

Figure 3: Selection of the running direction

An exception is pile-up operation: in this case turn the belt.



Figure 4: Running direction at pile-up operation

- Adjust the conveyor belt frames towards each other in true alignment (figure 5)

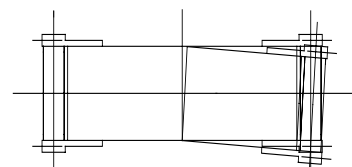
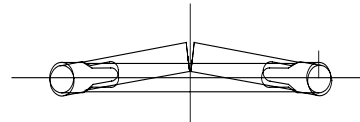

Figure 5: Adjustment of the conveyor belt

- Mount the conveyor belt frames with the elements of the connecting station.
- Adjust the axles of the drive and deflection rollers towards each other and to the conveyor belt frame in true alignment (Figure 6).

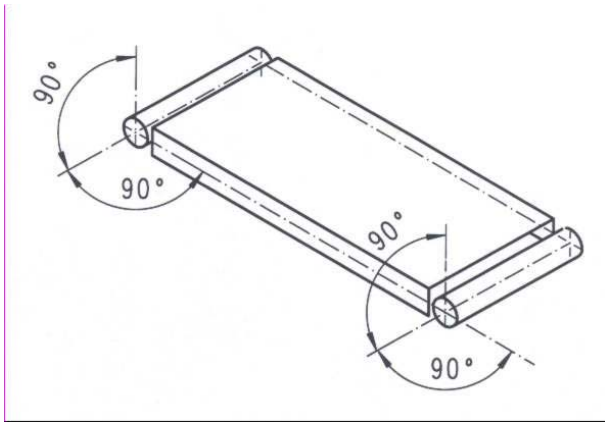

Figure 6: Alignment of the axles



Careful!

Mount the protective covering before starting the conveyor belt.

4.2.3 Mounting of RNA-stands

When mounting the conveyor belt on the delivered RNA-stands proceed as follows:

- Adjustment of the stand height
The stand height can be adjusted by ± 70 mm. For transport always the lowest height is adjusted. Dimension of the stand lug top edge to transport height:
 - FK 120 (sheet metal conveyor belt frame): approx. 40 mm
 - FP 120 (aluminium section frame): approx. 11 mm

Loosen the screws at the stand support. Slide the tubes into each other until the required height is reached.



Attention

Support the upper part of the stand. Owing to its own weight the upper part of the stand can skid down while the screws are loosened. Danger of squeezing!

- Erect the stand and adjust it.
- *Only for stands with two feet:*
Mount the lateral connection, in order to get a solid unit.
- Check, whether the stand lugs are aligned. If not, the angle position of the stand lugs can be corrected after loosening the fastening screws. After finishing the adjustment the fastening screws must be retightened!

- FK 120 (sheet metal conveyor belt frame)
- Loosen the screws of the clamping lugs so that the conveyor belt frame can be put between stand lug and clamping lug. After that retighten the screws of the clamping lugs.

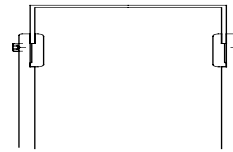

Figure 7: Mounting the sheet metal belt frame

- FP 120 (aluminium section frame). Unscrew the sliding blocks from the stand lugs. Insert the sliding blocks at the specified place at the conveyor belt frame and put the conveyor belt frame on top. Insert the screws again and tighten them.

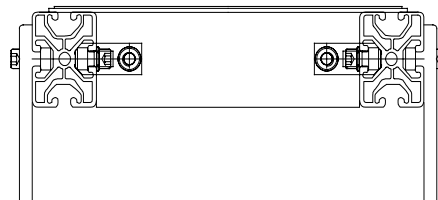

Figure 8: Mounting the aluminium section frame



Attention

The stands must in any case be fastened in the foundation by means of dowels. Operation without fastening in the foundation is not permitted!



Notice

Take care that the mounting of the conveyor belt is carried out distortion-free.

4.2.4 Drive (conveyor belts without RNA control units)

Have the motor connected by an electrician according to the connection diagram (see chapt. 1). After that check the direction of rotation.



Attention

Take care that the overload protection is adapted to the drive unit. The characteristic data are indicated on the type plate of the motor!



Attention

Before starting check the proper seat of the protective chain hood!

At drive units up to 750 watt the motor base plate can be swung by approx. 220°. For that loosen the set screw G in the clamping lug (see figure 9).



Careful!

Before loosening the set screw support the motor. Owing to its own weight (to approx. 14 kg) the motor swings automatically.

Swing the motor into the required position and re-tighten the set screw.

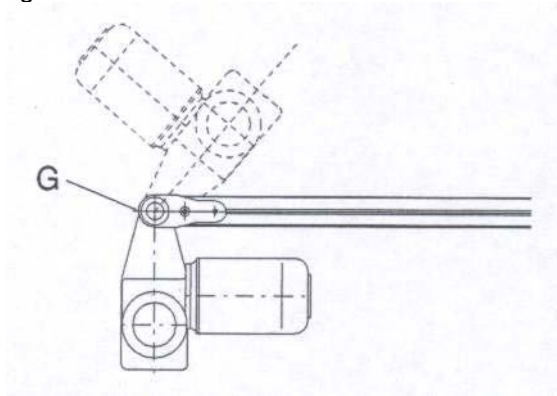

Figure 9: Swinging motor base plate

G = grub screw



Attention

At gear motors with vent screw: Remove the upper screw plug and insert the vent screw (which is contained in the delivery).



Careful!

Protective motor switches (contained in the delivery) may not be operated upside-down. Then the protective function is no longer guaranteed. In that case mount the protective switch so that its mounting position is as specified.

4.2.5 Preadjustment of the belt run

The preadjustment of the belt run is only necessary after mounting conveyor belts delivered in multiple parts and depends on the design of the conveyor belt.

Tensioning station integrated into the deflecting station

- Loosen the set screws in the tensioning station at both sides of the conveyor belt frame so that the axle arms fit into the leading long holes.
- Tighten the set screws evenly (count the rotations!) until the belt is slightly tensioned.
- Start the motor. Continue tightening the set screws evenly, until the belt is carried by the drive shaft free from slipping.



Notice

In case slipping occurs under operating load, tighten the set screws evenly (count the rotations!), until the belt is carried by the drive shaft free from slipping.

- Carry out the adjustment of the belt run as described in chapt. 5.

Tensioning station in the middle of the conveyor belt or central drive

- Loosen the set screws so that the axle arms fit into the ends of the leading long holes.
- Tighten the set screws at both conveyor belt frames evenly (count the rotations!), until the belt is slightly tensioned.
- Start the motor. Keep on tightening a pair of set screws belonging to the same deflection roller until the belt is carried under nominal load by the drive roller free from slipping.
- Carry out the adjustment of the belt run as described in chapter 5.

5. Starting



Attention

The electric connection of the conveyor belt may only be carried out by trained electricians! In any case observe the operating instructions of the protective motor switch or the control unit for carrying our modifications at the electric connection.

Switching on and off of the conveyor belt takes place at the protective motor switch, which is mounted beside the motor.

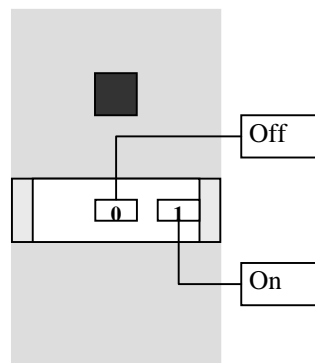

Figure 10: Protective motor switch

For conveyor belts equipped with other control units, operation of the control unit is taken from the operating instructions separately delivered.

Adjustment of the belt run

Motor and conveyor belt were tested at the manufacturer's plant and went through a final inspection. An adjustment of the belt run may become necessary when the conveyor belt is newly erected or owing to the running-in behaviour of the belt. This fine adjustment is made by means of set screws, which are integrated in the deflecting station.

The following figure shows the details of the deflecting station:

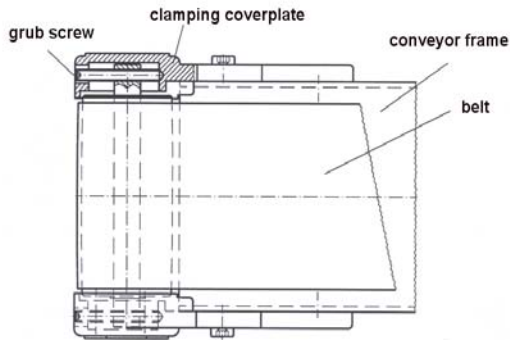

Figure 11: Deflecting station

In case the belt runs off-center after starting the motor, first carry out the adjustment in the deflecting station. In case this is not sufficient, make the adjustment in the drive station.

Adjustment of the deflecting station

- Tighten the set screw GS at that side to which the belt run is directed (tension the belt), or
- loosen the set screw GS at the opposite side (slacken the belt)

Adjustment in the drive station (only to execute at exceptional case)

- Increase the belt tension on the side to which the belt run is directed by slightly loosening the drive lug (or motor base plate over 750 W) and displace it horizontally, or
- reduce the belt tension on the opposite side correspondingly.
- After that screw down the lug again.



Careful!

A too high tension of the belt can overload the belt as well as the drive. After finishing the fine adjustment the current consumption of the motor must be measured. In case it exceeds the characteristic data on the type plate, the set screws GS must be loosened evenly.

After the adjustment a test run over several hours is absolutely necessary. During the first operating hours the belt must be checked in short intervals (approx. 2-3 times per day) for its centric run.

Change of the running direction

At the drive units a change of the running direction is generally possible. The running direction is marked with a red arrow on the protective chain hood. This arrow must be correspondingly adapted when the running direction is changed. As for each alteration of the delivery condition, the provisions of the Technical Plant and Equipment Act and the Accident Prevention Rules must be observed.



Careful!

In case the running direction of conveyor belts is changed, the safety trim panels may become ineffective. Restarting is prohibited as long as it has been checked that the Technical Plant and Equipment Act and the Accident Prevention Rules have been observed.

In case the belt is provided with an overlap connection (see figure 3 on page 7), the belt should be turned.

Tensioning and adjusting the belt is carried out as described in chapter 4.2.5 and chapter 5.

6. Maintenance



Attention

When starting, maintaining and repairing the conveyor belt it must be all-pole separated from the mains. Work at electric equipment of the conveyor belt may only be carried out by an electrician or by persons trained in electrical engineering (see chapt. 2) under the supervision of an electrician according to the electronics regulations.

6.1 Belt

In case the belt is dirty, clean it with spirit and a non-fluffy cloth. For conveyor belts used for food-stuff use a permissible spirit substitute.



Attention

Take care that there is sufficient ventilation! Do always wear protective clothes.

6.2 Motor

At d.c. motors the carbon brushes must be replaced after 2000 operating hours. After that thoroughly clean their surrounding.

Gear motors are maintenance-free for 10,000 operating hours.

Depending on the dust deposit, clean the protective fan hood of the motor, the motor itself and the gear unit so that sufficient cooling of the drive unit is always guaranteed.

6.3 Gear unit

When being delivered the gear units are ready for operation and are filled with gear lubricant and oil. Consequently a long-term lubrication is guaranteed for all movable parts.

Dismounting, cleaning and changing the oil is not necessary.

6.4 Chain drive

Depending on the load the tension of the chain drive must be checked in regular intervals and it must be lubricated.

The lubrication can be made with a commercially available chain grease.



Notice

Check the chain tension in regular intervals.

For that remove the protective chain hood and clean the pinions and the chain from dirt and old residues of lubricant. After that remount the protective chain hood.



Careful!

Before restarting control the proper seat of the protective chain hood.

6.5 Deflection, drive and supporting rollers

In case the rollers are dirty, clean them with spirit and a clean, non-fluffy cloth. For conveyor belts used for foodstuff use a permissible substitute.



Careful!

Take care that there is sufficient ventilation! Do always wear protective clothes.

6.6 Environmental influences

When erecting the conveyor belt, take care that the belts are not exposed to severe heat radiation. Observe the permissible temperatures of the belts (see brochure). Otherwise the belts can extend and slip through at the drive rollers.

Keep away oil, chips, etc from the conveyor belt.

7. Stockkeeping of spare parts and after sales service

An overview of the available spare parts may please be taken from the separate spare parts sheet.

In order to guarantee quick and faultless handling of the order, please always state the type of equipment (see type plate), number of pieces needed, spare part name and spare part number.

You will find a list of our service addresses on the back page of the cover.



D

Rhein-Nadel Automation GmbH

Reichsweg 19/42 • D - 52068 Aachen
Tel (+49) 0241/5109-159 • Fax (+49) 0241/5109-219
Internet www.rna.de • Email vertrieb@rna.de

Rhein-Nadel Automation GmbH

Zweigbetrieb Lüdenscheid
Nottebohmstraße 57 • D - 58511 Lüdenscheid
Tel (+49) 02351/41744 • Fax (+49) 02351/45582
Email werk.luedenscheid@rna.de

Rhein-Nadel Automation GmbH

Zweigbetrieb Ergolding
Ahornstraße 122 • D - 84030 Ergolding
Tel (+49) 0871/72812 • Fax (+49) 0871/77131
Email werk.ergolding@rna.de

CH

HSH Handling Systems AG

Wangenstr. 96 • CH - 3360 Herzogenbuchsee
Tel (+41) 062/95610-00 • Fax (+41) 062/95610-10
Internet www.rna.de • Email info@handling-systems.ch

GB

RNA AUTOMATION LTD

Hayward Industrial Park
Tameside Drive, Castle Bromwich
GB - Birmingham, B 35 7 AG
Tel (+44) 0121/749-2566 • Fax (+44) 0121/749-6217
Internet www.rna-uk.com • Email rna@rna-uk.com

E

Vibrant S.A.

Pol. Ind. Famades C/Energia Parc 27
E - 08940 Cornellà Llobregat (Barcelona)
Tel (+34) 093/377-7300 • Fax (+34) 093/377-6752
Internet www.vibrant-rna.com • Email info@vibrant-rna.com

CAN

RNA Automated Systems Inc.

1349 Sandhill Drive Unit 101
Ancaster, Ontario
Canada, L9G 4V5
Tel (+1) 905/3049950 • Fax (+1) 905/3049951
Mobil (+1) 905/9756562
Email sales@rna-can.com
www.rna-can.com