

Ersatzteilliste

Spare parts list
Liste des pièces de rechange
Lista delle parti di ricambio
Lista de recambios

Linearförderer

Linear Feeders
Vibreurs Linéaires
Vibratore Lineare
Vibrador Lineal

Typ	GL 01
Typ	GL 1
Typ	SLK-N6 / SLK-N6G
Typ	SLL 175
Typ	SLL 400
Typ	SLL 800 / SLL 804
Typ	SLF 1000-1000
Typ	SLF 1000-1500

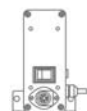
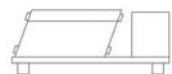
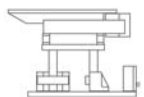

Nahezu 2000 komplette Zuführanlagen werden jährlich durch RNA ausgeliefert. Aufgrund unserer umfassenden Erfahrungen in der Zuführtechnik sind alle Bauelemente in hohem Maße praxiserprobt und zeichnen sich durch außerordentliche Zuverlässigkeit und Robustheit aus. Neue Erkenntnisse für Produktverbesserungen fließen fortlaufend in die Weiterentwicklung aller Komponenten ein.

Wir liefern Ihnen ein komplettes Programm leistungsstarker Antriebe und Steuerungen sowie Zubehör von anerkannt hoher Qualität und Funktionalität, auch für Aufgaben mit besonderen Leistungsanforderungen.

Beste Service, sofortige Lieferbereitschaft und hohe Verfügbarkeit, ebenso wie Ausführungen für die Bereiche Pharma und Lebensmittel, sowie Zulassungen nach dem UL- und CSA-Standard runden unser Produktprogramm ab.

Alle Komponenten werden vor Auslieferung nochmals auf Herz und Nieren geprüft, um ihren störungsfreien Einsatz zu gewährleisten.

Last but not least stehen hinter allen Produkten unsere Mitarbeiter. Der Maßstab für ihre Arbeit ist die Zufriedenheit unserer Kunden. Wir wissen, dass dauerhafter geschäftlicher Erfolg nur durch beste Qualität erzielbar ist, indem stets alle Anforderungen einer Aufgabenstellung umfassend erfüllt werden.

Wir freuen uns auf das Gespräch mit Ihnen!

With many years experience in the parts handling industry and nearly 2000 complete feed systems supplied annually, RNA have earned a reputation for the most robust and reliable equipment on the market. Our commitment to research and development maintains our position at the leading edge of feeding technology.

We provide an extensive range of the most efficient drive units, controllers and accessories for either standard or special requirements. All equipment is manufactured to the highest standards of quality upon which we have built our reputation.

We offer a first class service and for standard equipment, immediate delivery from stock. Our product range is manufactured to meet the highest demands of the food and pharmaceutical industries and also includes equipment manufactured to UL and CSA standards.

Quality has always been of central importance to RNA, with each employee committed to make their own personal contribution to the achievement of quality standards and customer satisfaction. We know that long term success in business can only be achieved by providing high quality equipment, which fulfills the customers requirements.

We are pleased to get in contact with you!

Typ	zu finden auf / find on	
Typ GL 01	Seite / page	6
Typ GL 1	Seite / page	8
Typ SLK-N6 / SLK-N6G	Seite / page	10
Typ SLL 175	Seite / page	12
Typ SLL 400	Seite / page	14
Typ SLL 800 / SLL 804	Seite / page	16
SLF 1000-1000 / SLF 1000-1500	Seite / page	18



ZERTIFIKAT DIN EN ISO 9001

DEKRA Certification Services GmbH
bescheinigt hiermit, daß das Unternehmen



RHEIN-NADEL AUTOMATION GMBH

**Bereiche: Schwingförderer, Förderbänder, Bunker,
Zuführ- und Transportanlagen**

Standorte:

D-52068 Aachen	Reichsweg 19-42
D-58511 Lüdenscheid	Nottebohmstraße 57
D-84030 Ergolding	Ahornstraße 122
D-99885 Ohrdruf	Suhler Straße 2a

ein Qualitätsmanagementsystem entsprechend der oben
genannten Norm (8/94) eingeführt hat und dieses
wirksam anwendet. Der Nachweis wurde im
Rahmen des Zertifizierungs-Audits,
Bericht-Nr. Z2970006 erbracht.

Datum der Erstzertifizierung:	27.05.1997	Datum der letzten Rezertifizierung:	--/--/----
Dieses Zertifikat ist gültig bis:	30.06.2000	Zertifikat-Registrier- Nr.:	40697348



DEKRA Certification Services GmbH (DCS) GmbH
Stuttgart, 25.06.1998

Akkreditiert durch die TGA
im Deutschen Akkreditierungs Rat



Deutscher
Akkreditierungs
Rat
Reg.Nr.: TGA-ZM-05-91-00

DEKRA Certification Services GmbH · Schulze-Delitzsch-Straße 49 · D-70565 Stuttgart



Certificate of Compliance

Certificate: 1360780	Master Contract: 217532
Project: 1360780	Date Issued: February 12, 2003
Issued to: Rhein-Nadel Automation GmbH Reichsweg 19/42 D-52068 Aachen GERMANY	

*The products listed below are eligible to bear the CSA Mark shown
with adjacent indicators 'C' and 'US'*





Authorized by: Davey Li, P. Eng.
Manager - Engineering

PRODUCTS

CLASS 3882 01 - CONVEYORS
CLASS 3882 81 - CONVEYORS – CERTIFIED TO U.S. STANDARDS

Component Type Electromagnetic vibration type conveyors:
-Rating 110V, 60Hz, 1-ph; Types GL01, 1A, GL1, 1.8A, SLL400-xx, 1A, SLL800-xx, and SLL804-xx, 2.27A, SLF1000-xx, 5.5A, SRC-N-160xx, 1A, SRC-N-200-xx, 2.65A, SRC-N-250-xx, 5.7A, SRC-N-400-xx, 7.25A-9.6A, SRHL-400-xx, 12.43A, SRC-N-630-xx, 9.6A, SRC-N-800-xx, 18.54A.

Note: The xx in the type designation is replaced by figures and/or letters denoting mechanical details not related to electrical safety.

APPLICABLE REQUIREMENTS

C22.2 No. 0	-	1992	-	General Requirements
C22.2 No. 68	-	1987	-	Motor Operated Equipment
C22.2 No. 100	-	1995	-	Motors and Generators (used as guide)
UL 73	-		-	Motor Operated Equipment
UL 1004	-		-	Electric Motors (used as guide)

The 'C' and 'US' indicators adjacent to the CSA Mark signify that the product has been evaluated to the applicable CSA and ANSI/UL Standards, for use in Canada and the U.S., respectively. This 'US' indicator includes products eligible to bear the 'NRTL' indicator. NRTL, i.e. National Recognized Testing Laboratory, is a designation granted by the U.S. Occupational Safety and Health Administration (OSHA) to laboratories which have been recognized to perform certification to U.S. Standards.

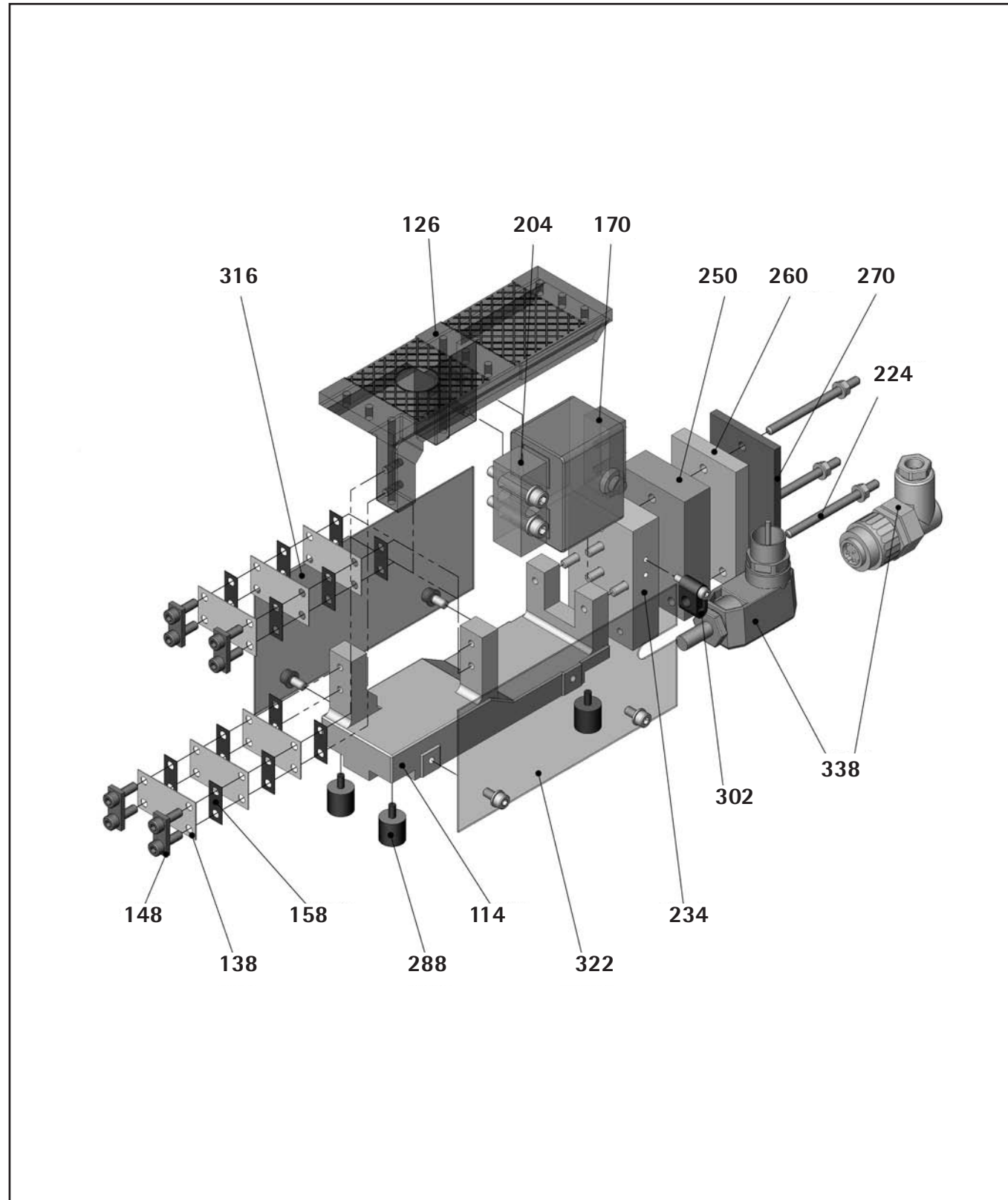

Pos	Benennung Designation Désignation Denominazione Denominación
114	Gegenmasse Counter-mass Contremasse Contromassa Contramasa
126	Schwinger Vibrator Top Casting Vibrant Piaffello vibrante Oscillante
138	Blattfeder Leaf spring Ressort à lame Balestra Muelle
148	Endplatte End plate Plaque terminale Plastrina secundaria Placa de aprieto
158	Zwischenplättchen Shims Plaquettes intercalaires Spessore Placa intermedia
170	Magnet Magnet Aimant Magnete Imán
204	Anker Armature Amature Armatura Armadura
224	Gewindestück M5x70 Threaded bolt Pièce fileté Piezza filetata Filete

Pos	Benennung Designation Désignation Denominazione Denominación
234	Kontergewicht 50x20x80 Counter weight Contre-poids Contrapeso Contrapeso
250	Zusatzgewicht
260	Additional weight
270	Poids supplémentaire Peso addizionale Peso adicional
288	Puffer 15x15xM4 Vibra stop. Plot Vibra stop. Amortiguador
302	Zugentlastung Tension relief Décharge de tension Scarico della tensione Descarga de tensión
316	Seitenwand ohne Aussparung Sidewall without recess Paroi sans évidement Sponda laterale senza incavo Pared sin entalladora
322	Seitenwand mit Aussparung Sidewall with recess Paroi avec évidement Sponda laterale con incavo Pared con entalladora
338 *	Stecker Plug cable Prise cable Preso cavo Enchufe

* Bei Bestellung der Pos. 338 bitte die Ausführung CE oder CSA/UL angeben
 When ordering item 338 kindly indicate CE or CSA/UL design
 Lors de la commande de la pos. 338 indiquer clairement l'écécution CE ou CSA/UL
 Per ordinare voce 338 preghiamo indicare chiaramente l'esecuzione CE o CSA/UL
 Al hacer e' pedido para pos 338, sirvase indicar la ejecución CE o CSA/UL

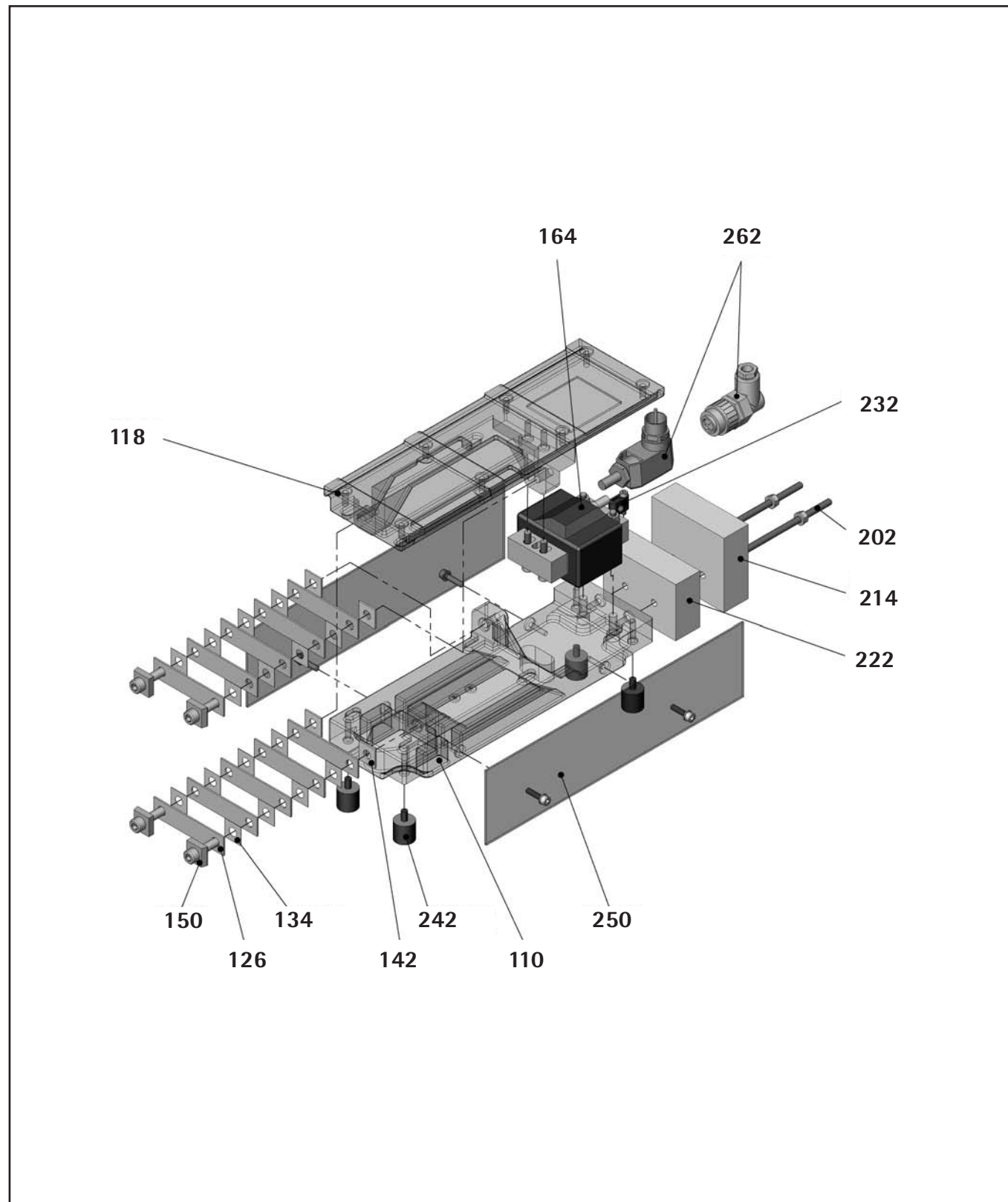

Pos	Benennung Designation Désignation Denominazione Denominación
110	Gegenmasse Counter-mass Contremasse Contromassa Contramasa
118	Schwinger Vibrator Top Casting Vibrant Piattello vibrante Oscillante
126	Blattfeder Leaf spring Ressort à lame Balestra Muelle
134	Zwischenplättchen Shims Plaquettes intercalaires Spessore Placa intermedia
142	Endplatte End plate Plaque terminale Piastrina secondaria Placa de aprieto
150	Klemmplatte Clamping plate Plaque de blocage Piastrina primaria Placa de aprieto
164	Magnet Magnet Aimant Magnete imán

Pos	Benennung Designation Désignation Denominazione Denominación
202	Gewindestück M6x110 Threaded bolt Pièce filetée Piezza filetata Filete
214	Kontergewicht 90x30x80 Counter weight Contre-poids Contrapeso Contrapeso
222	Kontergewicht 90x30x60 Counter weight Contre-poids Contrapeso Contrapeso
232	Zugentlastung Tension relief Décharge de tension Scarico della tensione Descarga de tensión
242	Puffer Vibra stop. Plot Vibra stop. Amortiguador
250	Seitenwand Sidewall Paroi Sponda laterale Pared
262 *	Stecker Plug cable Prise cable Presacavo Enchufe

* Bei Bestellung der Pos. 262 bitte die Ausführung CE oder CSA/UL angeben
 When ordering item 262 kindly indicate CE or CSA/UL design
 Lors de la commande de la pos. 262 indiquer clairement l'exécution CE ou CSA/UL
 Per ordinare voce 262 preghiamo indicare chiaramente l'esecuzione CE o CSA/UL
 Al hacer e pedido para pos.262, sírvase indicar la ejecución CE o CSA/UL

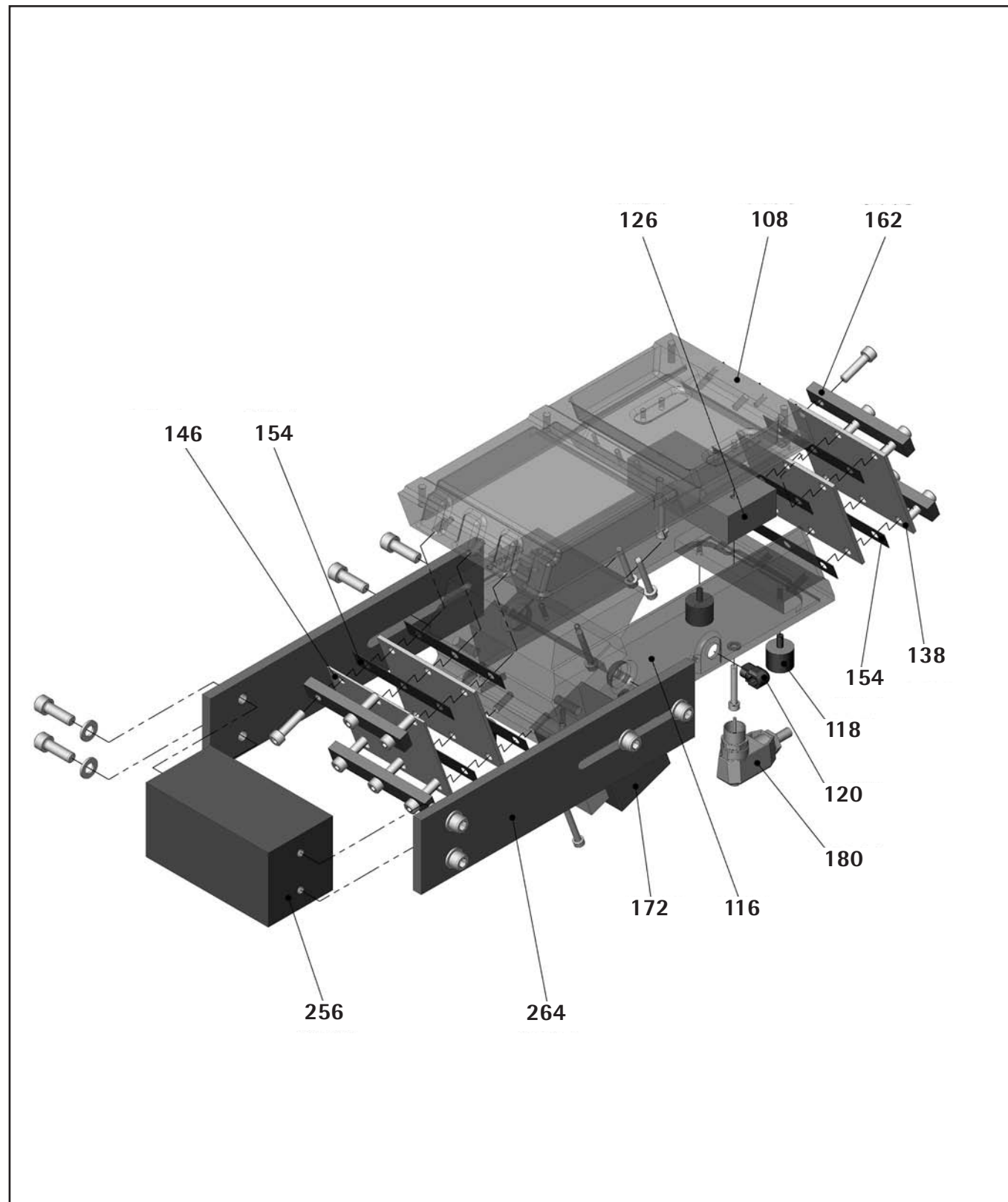

Pos	Benennung Designation Désignation Denominazione Denominación	SLK-N6	SLK-N6G
108	Schwinger Vibrator Top Casting Vibrant Piattello vibrante Oscillante	•	•
116	Gegenmasse Counter-mass Contremasse Contromassa Contramasa	•	•
118	Puffer Vibra stop. Plot Vibra stop. Amortiguador	•	•
120	Zugentlastung Tension relief Décharge de tension Scarico della tensione Descarga de tensión	•	•
126	Zusatzgewicht Additional weight Poids supplémentaire Peso addizionale Peso adicional	•	•
138	Blattfeder Leaf spring	•	•
146	Blattfeder Ressort à lame Balestra Muelle	•	•

Pos	Benennung Designation Désignation Denominazione Denominación	SLK-N6	SLK-N6G
154	Zwischenplättchen Shims Plaquettes intercalaires Spessore Placa intermedia	•	•
162	Klemmplatte Clamping plate Plaque de blocage Piastrina primaria Placa de aprieto	•	•
172	Magnet magnet Aimant Magnete Imán	•	•
180	Stecker Plug cable Prise cable Presca cavo Enchufe	•	•
256	Kontergewicht Counter weight Contre-poids Contrapeso Contrapeso		•
264	Lasche Kontergewicht Counterweight plate Attache contre-poids Coprigiunto contrapeso Cubrejunta contrapeso		•

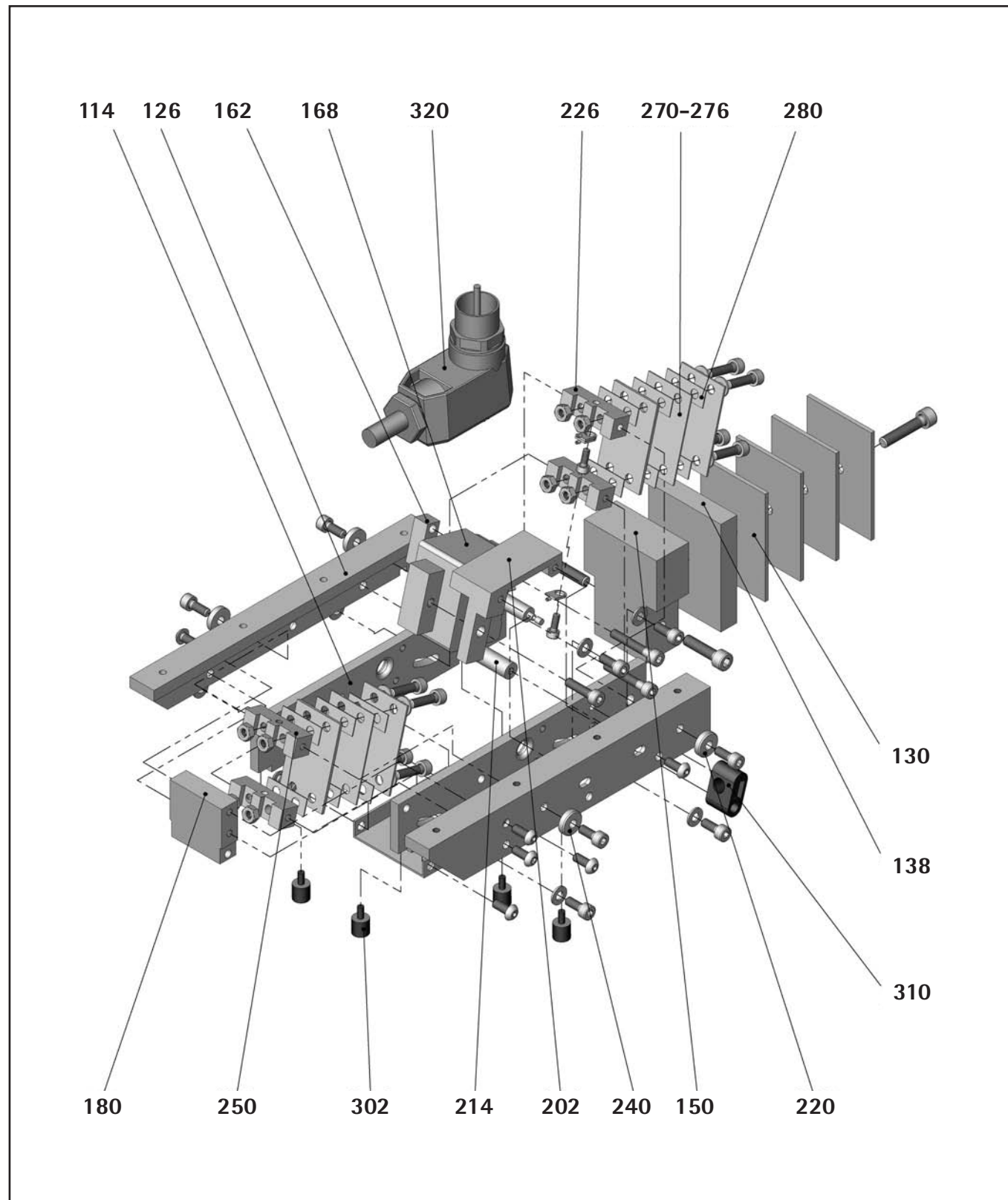

Pos	Benennung Designation Désignation Denominazione Denominación	SLL 175-175	SLL 175-250
114	Gegenmasse Counter-mass Contremasse Contromassa Contramasa	•	•
126	Schwinger Vibrator Top Casting Vibrant Piattello vibrante Oscillante	•	•
130	Kontergewicht Counter weight		•
138	Contre-poids		
150	Contrapeso		
162	Distanzstück		
180	Spacer.	•	•
214	Interculaire Spaziatore Distanciador	•	•
168	Magnet Magnet Aimant Magnete Imán	•	•
202	Ankeraufnahme Armature fixing Fixation armature Fissaggio armatura Fijación armatura	•	•
220	Scheibe		
240	Washer Rondelle Rondella Arandela	•	•

Pos	Benennung Designation Désignation Denominazione Denominación	SLL 175-175	SLL 175-250
226	Federaufnahm Einlauf Springs mounting inlet Logement aimants entrée Fissaggio balestre entrata Receptor muelles entrada	•	•
250	Federaufnahm Auslauf Springs mounting outlet Logement aimants sortie Fissaggio balestre uscita Receptor muelles salida	•	•
270	Blattfeder		
272	Leaf spring	•	•
274	Ressort à lame	•	•
276	Balestra Muelle		
280	Zwischenplättchen Shims Plaquettes intercalaires Spessore Placa intermedia	•	•
302	Puffer Vibra stop. Plot Vibra stop. Amortiguador	•	•
310	Zugentlastung Tension relief Décharge de tension Scarico della tensione Descarga de tensión	•	•
320	Stecker Plug cable Prise cable Presca cavo Enchufe	•	•

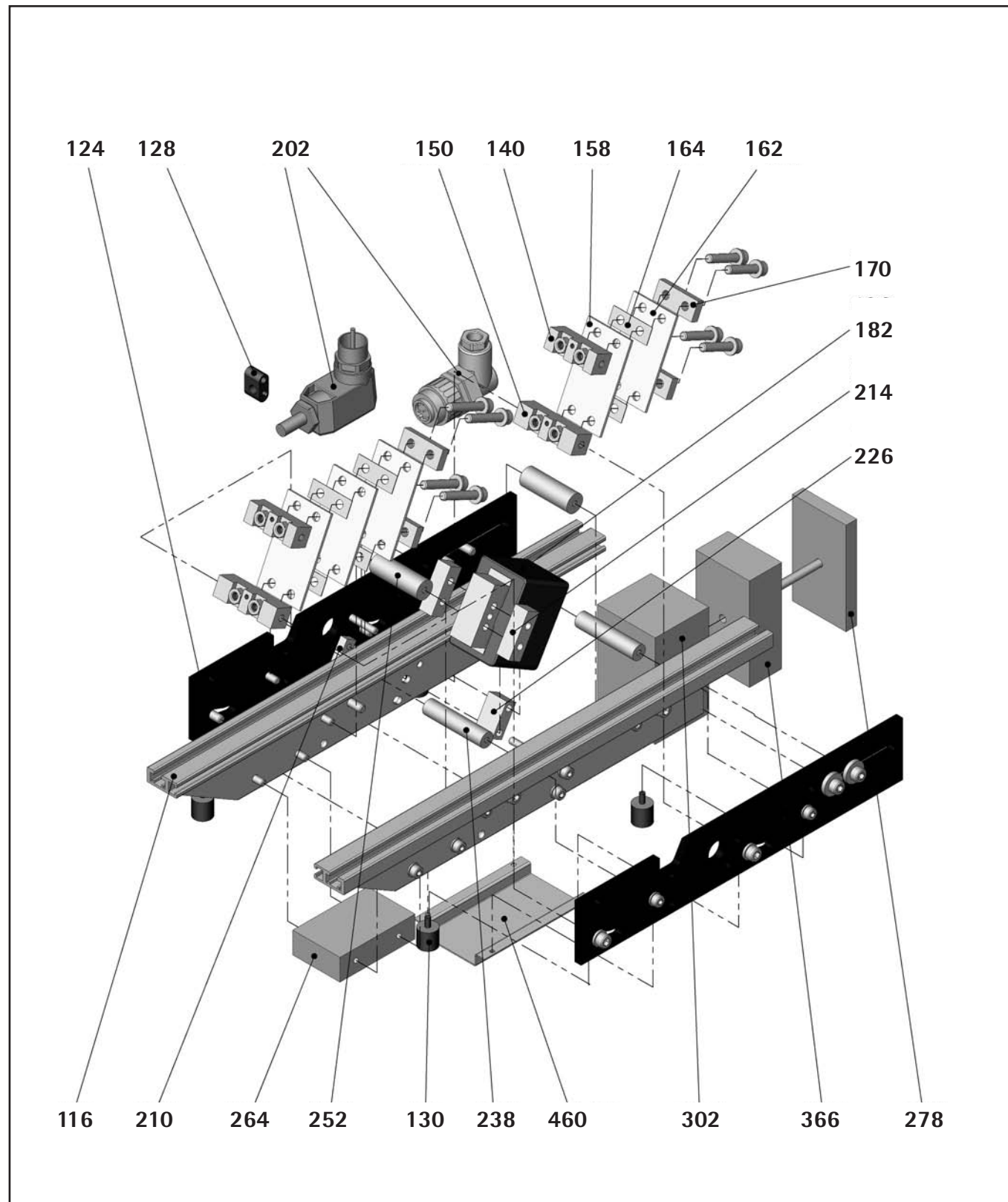

Pos	Benennung Designation Désignation Denominazione Denominación
116	Schwinger Vibrator Top Casting Vibrant Piattello vibrante Oscillante
124	Gegenmasse Counter-mass Contremasse Contromassa Contramasa
128	Zugentlastung Tension relief Décharge de tension Scarico della tensione Descarga de tensión
130	Puffer Vibra stop. Plot Vibra stop. Amortiguador
140	Federaufnahme Springs mounting Logement aimants Fissaggio balestre Receptor muelles
150	Feder Leaf spring Ressort à lame Balestra Muelle
158	Blattfeder Leaf spring Ressort à lame Balestra Muelle
162	Blattfeder Leaf spring Ressort à lame Balestra Muelle
164	Zwischenplättchen Shims Plaquettes intercalaires Spessore Placa intermedia
170	Endplatte End plate Plaque terminale Piastrina secondaria Placa de aprieto

Pos	Benennung Designation Désignation Denominazione Denominación
182	Magnet Magnet Aimant Magnete Imán
202 *	Stecker Plug cable Prise cable Presà cavo Enchufe
210	Ankerbefestigung Armature fixing Fixation armature Fissaggio armatura Fijación armatura
214	Distanzstück Spacer
238	Spacer
252	Interculaire Spaziatore Distanciador
226	Magnetbefestigung Magnet fixing Fixation aimant Fissaggio magnete Fijación imanes
264	Zusatzgewicht Additional weight
278	Additional weight
366	Poids supplémentaire Peso addizionale Peso adicional
302	Kontergewicht Counter weight Contre-poids Contrapeso Contrapeso
460	Abdeckung (nur CSA/UL Ausführung) Cover (only CSA/UL design) Couvercle (seulement pour l'exécution CSA/UL) Copertura (solamente per l'esecuzione CSA/UL) Cubierto (solamente para la ejecución CSA/UL)

* Bei Bestellung der Pos. 202 bitte die Ausführung CE oder CSA/UL angeben
 When ordering item 202 kindly indicate CE or CSA/UL design
 Lors de la commande de la pos. 202 indiquer clairement l'exécution CE ou CSA/UL
 Per ordinare voce 202 preghiamo indicare chiaramente l'esecuzione CE o CSA/UL
 Al hacer e pedido para pos. 202, sirvase indicar la ejecución CE o CSA/UL

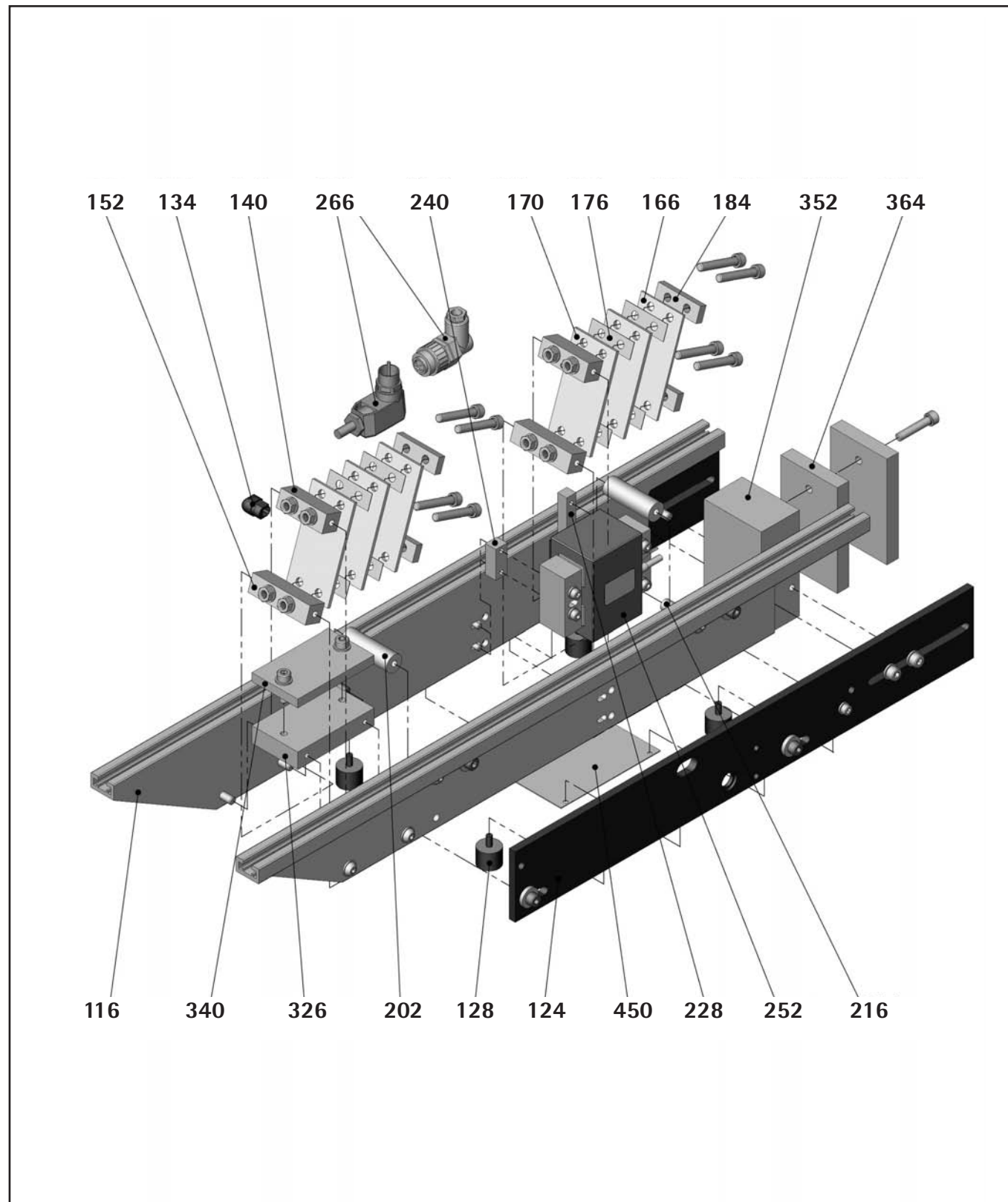

Pos	Benennung Designation Désignation Denominazione Denominación	SLL 800	SLL 804
116	Schwinger Vibrator Top Casting Vibrant Piattello vibrante Oscillante	•	•
124	Gegenmasse Counter-mass Contremasse Contromassa Contramasa	•	•
128	Puffer Vibra stop. Plot Vibra stop. Amortiguador	•	•
134	Zugentlastung Tension relief Décharge de tension Scarico della tensione Descarga de tensión	•	•
140	Federaufnahme Springs mounting Logement aimants Fissaggio balestre Receptor muelles	•	•
152			
166	Blattfeder Leaf spring Ressort à lame Balestra Muelle	•	•
170			
176	Zwischenplättchen Shims Plaquettes intercalaires Spessore Placa intermedia	•	•

Pos	Benennung Designation Désignation Denominazione Denominación	SLL 800	SLL 804
184	Endplatte End plate Plaque terminale Piastrina secondaria Placa de aprieto	•	•
202	Distanzstück Spacer Interculaire Spaziatore Distanciador	•	•
216			
228	Magnetbefestigung Magnet fixing Fixation aimant Fissaggio magneti Fijación imanes	•	•
240			
252	Magnet Magnet Aimant Magnete Imán	•	•
266*	Stecker Plug cable Prise cable Presa cavo Enchufe	•	•
326	Zusatzgewicht Additional weight Poids supplémentaire Peso addizionale Peso adicional	•	•
340			
352	Kontergewicht Counter weight Contre-poids Contrapeso Contrapeso	•	•
364			
450	Abdeckung (nur CSA/UL Ausführung) Cover (only CSA/UL design) Couvercle (seulement pour l'exécution CSA/UL) Copertura (solamente per l'esecuzione CSA/UL) Cubierto (solamente para la ejecución CSA/UL)		

* Bei Bestellung der Pos. 266 bitte die Ausführung CE oder CSA/UL angeben
 When ordering item 266 kindly indicate CE or CSA/UL design
 Lors de la commande de la pos. 266 indiquer clairement l'exécution CE ou CSA/UL
 Per ordinare voce 266 preghiamo indicare chiaramente l'esecuzione CE o CSA/UL
 Al hacer e' pedido para pos. 266, sirvase indicar la ejecución CE o CSA/UL

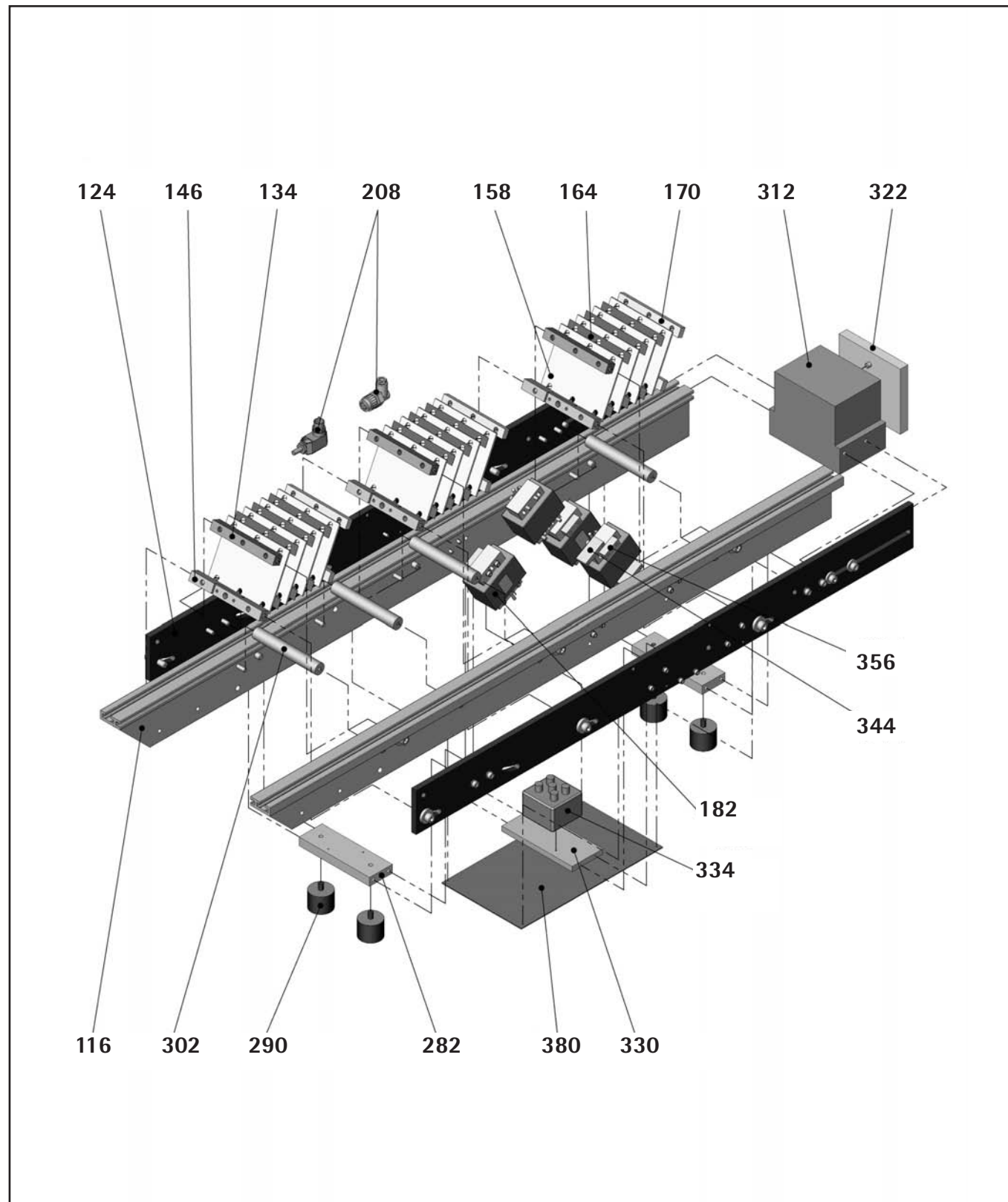

Pos	Benennung Designation Désignation Denominazione Denominación	SLF 1000-1000	SLF 1000-1500
116	Schwinger Vibrator Top Casting Vibrant Piattello vibrante Oscillante	•	•
124	Gegenmasse Counter-mass Contremasse Contromassa Contramasa	•	•
134	Federaufnahme Springs mounting Logement aimant Fissaggio balestre Receptor muelles	•	•
146			
158	Blattfeder Leaf spring Ressort à lame Balestra Muelle	2x4	3x4
164	Zwischenplättchen Shims Plaquettes intercalaires Spessore Placa intermedia	2x8	3x8
170	Endplatte End plate Plaque terminale Piastrina secondaria Placa de aprieto	•	•
182	Magnet Magnet Aimant Magnete Imán	2x	4x
208*	Stecker Plug cable Prise cable Presa cavo Enchufe	•	•
282	Aufnahmeplatte Puffer Take-up buffer Logement tampon Piastra di fissaggio tampone Receptor tampón	•	•

Pos	Benennung Designation Désignation Denominazione Denominación	SLF 1000-1000	SLF 1000-1500
290	Puffer Vibra stop. Plot Vibra stop. Amortiguador	•	•
302	Distanzstück Spacer Intercalaire Spaziatore Distancidor	2x	4x
312	Kontergewicht Counter weight Contre-poids Contrapeso Contrapeso	•	•
322	Zusatzgewicht Additional weight Poids supplémentaire Peso adicional Peso adicional	•	•
330	Aufnahmeplatte Take-up plate Plaque de fixation Piastra di fissaggio Receptor		•
334	Klemmenkasten Connection housing Boîte de raccordement Scatola morsetti Caja de bornes	•	•
344	Magnetbefestigung Magnet fixing Fixation aimant Fissaggio magnete Fijación imanes	2x	4x
356	Ankerbefestigung Armature fixing Fixation armature Fissaggio armatura Fijación armadura	2x	4x
380	Abdeckung (nur CSA/UL Ausführung) Cover (only CSA/UL design) Couvercle (seulement pour l'exécution CSA/UL) Copertura (solamente per l'esecuzione CSA/UL) Cubierto (solamente para la ejecución CSA/UL)		

* Bei Bestellung der Pos. 208 bitte die Ausführung CE oder CSA/UL angeben
 When ordering item 208 kindly indicate CE or CSA/UL design
 Lors de la commande de la pos. 208 indiquer clairement l'exécution CE ou CSA/UL
 Per ordinare voce 208 preghiamo indicare chiaramente l'esecuzione CE o CSA/UL
 Al hacer e pedido para pos. 208, sirvase indicar la ejecución CE o CSA/UL



Rhein-Nadel Automation GmbH
Reichsweg 19-42
D-52068 Aachen
Tel.: ++49 241 5109-0
Tel. Vertrieb: ++49 241 5109-159
Fax: ++49 241 5109-219
E-Mail: Vertrieb@rna.de
Internet: www.rna.de

HSH Handling Systems AG
Wangenstr. 96
CH-3360 Herzogenbuchsee

Tel.: ++41 62 956 10-00
Fax: ++41 62 956 10-10
E-Mail: info@handling-systems.ch
Internet: www.rna.de

RNA Automation LTD
Hayward Industrial Park Tameside Drive,
Castle Bromwich, Birmingham, B35 7AG

Tel.: ++44 121 749-2566
Fax: ++44 121 749-6217
E-Mail: rna@rna-uk.com
Internet: www.rna-uk.com

Vibrant S.A.
Pol. Ind. Famades c/Energia, Parc 27
E- 08940 Cornellà de Llobregat (Barcelona)

Tel.: ++34 93 377-7300
Fax: ++34 93 377-6752
E-Mail: info@vibrant-rna.com
Internet: www.vibrant-rna.com

Principal Agents

Palace Packaging Machines
4102 Edges Mill Rd.
Downingtown
PA. 19335-1954
United States

Tel: 610-873-7252
www.unscramblers.com

Stand: April 2004