

# Operating Instructions Conveyor Belts

**FP 15 E**  
**FP 15 D**

BA

Rhein-Nadel Automation GmbH

## Table of contents

Chapter		Page
<b>1</b>	<b>Technical data</b>	
1.1	Table	2
1.2	Connecting plans motors	3
<b>2</b>	<b>Safety instructions</b>	<b>4</b>
<b>3</b>	<b>Construction and function of the conveyor belts</b>	<b>5</b>
<b>4</b>	<b>Transport and mounting</b>	
4.1	Transport	5
4.2	Connecting the motor	5
<b>5</b>	<b>Starting</b>	<b>6</b>
<b>6</b>	<b>Maintenance</b>	
6.1	Belt	7
6.2	Motor	7
6.3	Gear unit	7
6.4	Deflection, drive and supporting rollers	7
6.5	Environmental influences	7
<b>7.</b>	<b>Stockkeeping of spare parts and after sales service</b>	<b>7</b>

## 1 Technical data

### 1.1 Table

Conveyor belt lengths = distance between conveyor centers	[mm]	200, 400, 600, 800, 1.000, 1.200, 1.400, 1.600, 1.800, 2.000
Belt widths	[mm]	10, 20, 30 and toroidal sealing ring diameter 3
Conveyor belt load	(kp)	5-10 total load
Belt speed +/-20%	(m/min.)	Constant: 9,15,21,37 (230/400 V 50 Hz) or 9,15 (23 V 50Hz) controllable 2-13 (24 VDC)
Regulating range (clearance) at FP 15 D	mm	0-25 adjustable 20-55 adjustable 50-80 adjustable
Current consumption		See type plate
Roller diameter	(mm)	30
Tension station		Integrated in the motor plate

## 1.2 Connecting plans motors

### 1.2.1 Threephase current motor

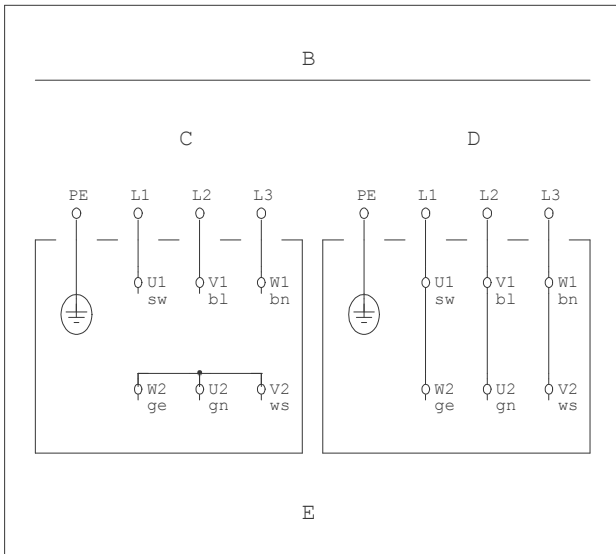

- B Connection to the 3-conductor-mains
- C Star connection (high voltage)
- D Triangle connection (low voltage)
- E For switching over the direction of rotation two phases of the supply must be exchanged!

### 1.2.2 A.C. motor Dunker

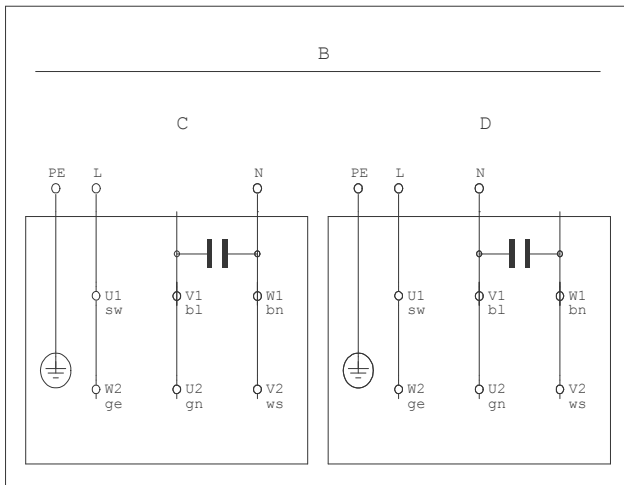

- B Connection to 2-conductor-mains
- C anti-clockwise
- D clockwise

### 1.2.3 D. C. motor Engel

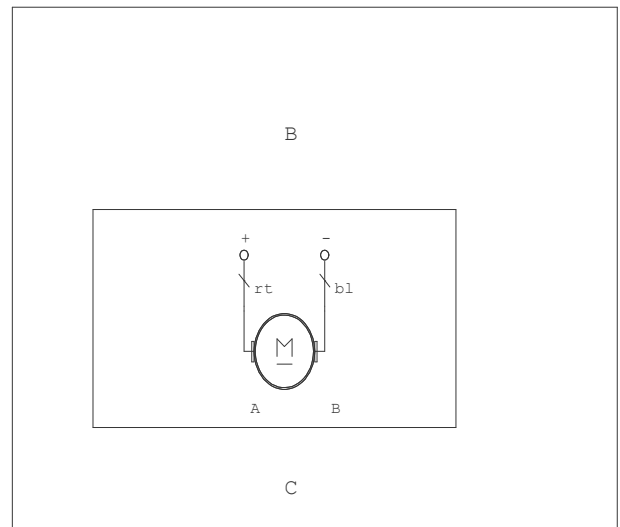

- B Armature circuit
- C For switching over the direction of rotation the armature wires A and B must be exchanged!

## 2. Safety instructions

The conception and production of our conveyor belts has been carried out very carefully, in order to guarantee trouble-free and safe operation. You too can make an important contribution to job safety. Therefore, please read the short operating instructions completely, before starting the machine. Always observe the safety instructions!



### Attention

This warning triangle marks safety instructions. Non-observance of these warnings can result in serious or fatal injuries!

---



### Careful!

This warning triangle marks safety instructions. Non-observance of this warning can result in slight personal injuries or property damage.

---



### Notice

This hand points to information that gives you useful tips for the operation of conveyor belts.

---

Make sure that all persons working with or at this machine carefully read and observe the following safety instructions!

The operating instruction is only valid for the types indicated on the front page.

It must always be available at the place of operation of the conveyor belt!

When using the conveyor belt in humid or wet environment (wet area) it has to be made sure that the required insulation type is provided.



### Notice

Detailed information on the total range of control units may please be taken from the operating instructions "control units".

---

Starting, conversion, maintenance and repair work may only be carried out by skilled and authorized personnel (see also "requirements on the user" in this chapter).

During assembly, maintenance and repair the conveyor belt must be all-pole separated from the mains according to the VDE-regulations.

Work at the electric equipment may only be carried out by an electrician or a person trained in electrical engineering under the supervision of an electrician, according to the electronics regulations.



### Attention

There is the danger of injuries and the danger of an electric shock!

---

- User and operator must take care that only authorized personnel works at the conveyor belt.
- The operator must immediately be informed about any changes impairing safety.
- Modifications impairing safety must immediately be reported to the operator.
- The conveyor belt may only be operated according to the intended use.
- Please observe the regulations for prevention of accidents VBG 10 for continuous conveyors and VBG 4 for electric plants and equipment!

### Dangers occurring at the machine

- In case the conveyor belt gets wet, there is the danger of an electric shock!
- Make sure that the protector ground of the electric power supply is in perfect condition!
- Operation of the conveyor belt without trim panels and protection hoods (chain drive) is prohibited in any case!

### Intended use

The intended use of conveyor belts is the transport of material.

The material to be transported must have a side length of at least 5 mm. By special designs or other equipment the conveyor belts can be retrofitted for material with smaller side length (>0.5 mm). If necessary, please turn to the manufacturer.



### Careful!

Smaller parts may get under the belt and cause damage or failure of the conveyor belt.

---

When using standard belts the material to be transported must be dry, clean and without sharp edges.



### Careful!

For the transport of material which could tip over, roll or slide, a sufficient number of solid lateral guiding appliances from the accessory parts programme must be used.

---

The conveyor belts are designed for horizontal transport at maximum load. A slight inclination of the transport plane is possible in the individual case. In this case ask the manufacturer for a definite individual solution!

The permissible belt load may please be taken from the technical data (chapt. 1).

### Noise emission

The constant sound level is at maximum 70 dB(A). Transporting the material or the belt condition can

produce a higher sound level. For these exceptional cases noise protection measures can be requested from the manufacturer.

### Requirements on the user

Starting, retrofitting as well as maintenance and repair work may only be carried out by skilled and authorized professionals.

We distinguish four qualification levels:

#### Skilled personnel

are persons who are familiar with the assembly, mounting, starting and operation of the conveyor belt. They are qualified appropriately to their task.

#### Authorized personnel

is skilled personnel, who is given a clearly defined task by the operator of the conveyor belt.

#### Electrician

(according to IEC 364 and DIN VDE 0105 part 1) is a person who, owing to her/his specialist qualifications, knowledge and experience, as well as knowledge of the relevant standards, is able to judge and recognize the tasks given to her/him, and who can see possible dangers.

#### Person trained in electrical engineering

(according to IEC 364 and DIN VDE 0105 part 1) is a person who is instructed by an electrician in the tasks she/he is given. She/he is also informed on possible dangers, in case of inexpert behaviour and on necessary protective equipment and measures.

### 3. Construction and function of the conveyor belts

The conveyor belts are made of a special aluminium slot section. For the actuation a wide range of motors for constant and controllable speed is available. The drive unit can be located either at the entry of the conveyor belt, at the end, or in the middle. Control of the conveyor belt takes place by protective motor switch, electronic control units or frequency-controlled control units, depending on the motor type.



#### Notice

Information on the control units may please be taken from the separate operating instructions "control units".

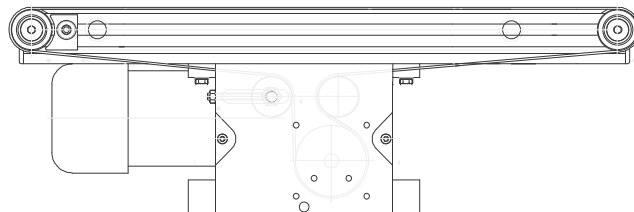

Figure 1: Construction of the conveyor belts

### 4. Transport and mounting

#### 4.1 Transport

##### Transport ex works

The conveyor belts are delivered ex works in cardboard boxes or cases.

##### Transport within the plant

The weight of the conveyor belt depends on the dimensions and on the motor capacity. Please take the weight of your special design from the freight documents.



#### Attention

When unpacking the equipment all protective devices must be controlled. Before starting, replace all damaged parts!

#### 4.2 Connecting the motor

Have the motor connected by an electrician according to the connection diagram (see chapt. 1). After that check the direction of rotation.



#### Attention

Take care that the overload protection is adapted to the drive unit. The characteristic data are indicated on the type plate of the motor!



#### Attention

Before starting check the proper seat of the protective chain hood!



#### Careful!

Protective motor switches enclosed in the consignment may not be operated faced down. The protective function would not be given then. In this case mount the protective switch in a way that the specified mounting position is guaranteed.

#### 4.3 Mounting on stands

When mounting the conveyor belt on a supporting table, it has to be taken care that the feet of the stand are tightly screwed down to the table.

---

**Attention**  
Unauthorized operation is not permitted!

---

When mounting the conveyor belt on a stand, the feet of the stand must be additionally anchored in the foundation by means of dowels.

## 5. Starting

---

**Attention**  
The electric connection of the conveyor belt may only be carried out by trained electricians!  
In any case observe the operating instructions of the protective motor switch or the control unit for carrying out modifications at the electric connection.

---

Switching on and off of the conveyor belt takes place at the protective motor switch.

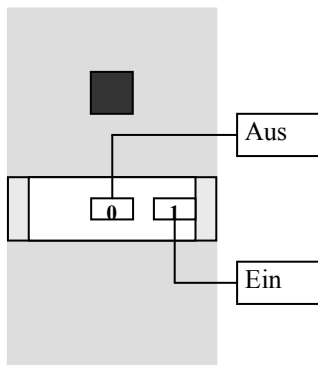

Figure 10: Protective motor switch

For conveyor belts equipped with other control units, operation of the control unit is taken from the operating instructions separately delivered.

### Adjusting the belt run

Motor and conveyor belt were tested at the manufacturer's plant and went through a final inspection. An adjustment of the belt run may become necessary when the conveyor belt is initially erected or owing to the running-in behaviour of the belt.

---

**Careful**  
A too tight tension of the belt can overload the belt as well as the drive. After the adjustment the current consumption of the motor must be measured. If the consumption exceeds the nominal values on the type plate, the tension of the belt must be reduced again.

---

### Adjusting the belt tension

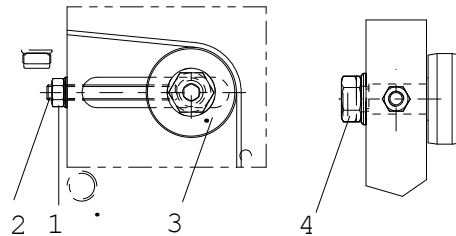

For the adjustment of the belt tension a tensioning device is integrated in the motor plate. In order to adjust the belt tension, the fastening nut (4) of the tension roller must slightly be loosened. After that the set screw (2) (after loosening the counter nut (1)) must be turned with a hexagon socket screw key. By that the position of the tension roller (3) of the belt is changed.

Tension roller in direction drive wheel = higher belt tension  
Tension roller in opposite direction of the drive wheel = low belt tension

The correct belt tension is achieved when the belt transports a load of 10 kp free from slipping.

---

**Careful**  
A too tight tension of the belt can overload the belt as well as the drive. After the adjustment the current consumption of the motor must be measured. If the consumption exceeds the nominal values on the type plate, the tension of the belt must be reduced again.

---

After the adjustment the fastening nut (4) and the counter nut (1) must be retightened again.

### Change of the running direction

At the drives used a change of the running direction is generally possible. As for every change in the delivery condition the regulations of the Technical Plant and Equipment Act and the Accident Prevention Rules must be observed.

---

**Careful**  
In case the running direction of conveyor belts is changed, the safety trim panels may become ineffective. Restarting is prohibited as long as it has been checked that the Technical Plant and Equipment Act and the Accident Prevention Rules have been observed.

---

## 6. Maintenance

**Attention**

When starting, maintaining and repairing the conveyor belt it must be all-pole separated from the mains. Work at electric equipment of the conveyor belt may only be carried out by an electrician or by persons trained in electrical engineering (see chapt. 2) under the supervision of an electrician according to the electronics regulations.

**6.1 Belt**

In case the belt is dirty, clean it with spirit and a non-fluffy cloth. For conveyor belts used for foodstuff use a permissible spirit substitute.

**Attention**

Take care that there is sufficient ventilation! Do always wear protective clothes.

**6.2 Motor**

At d.c. motors the carbon brushes must be replaced after 2000 operating hours. After that thoroughly clean their surrounding.

Gear motors are maintenance-free for 10.000 operating hours.

Depending on the dust deposit, clean the protective fan hood of the motor, the motor itself and the gear unit so that sufficient cooling of the drive unit is always guaranteed.

**6.3 Gear unit**

When being delivered the gear units are ready for operation and are filled with gear lubricant and oil.

Consequently a long-term lubrication is guaranteed for all movable parts.

Dismounting, cleaning and changing the oil is not necessary.

**6.4 Deflection, drive and supporting rollers**

In case the rollers are dirty, clean them with spirit and a clean, non-fluffy cloth. For conveyor belts used for foodstuff use a permissible substitute.

**Careful!**

Take care that there is sufficient ventilation! Do always wear protective clothes.

**6.5 Environmental influences**

When erecting the conveyor belt, take care that the belts are not exposed to severe heat radiation. Observe the permissible temperatures of the belts (see brochure). Otherwise the belts can extend and slip through at the drive rollers.

Keep oil, chips, etc away from the conveyor belt.

**7. Stockkeeping of spare parts and after sales service**

An overview of the available spare parts may please be taken from the separate spare parts sheet.

In order to guarantee quick and faultless handling of the order, please always state the type of equipment (see type plate), number of pieces needed, spare part name and spare part number.

You will find a list of our service addresses on the back page of the cover.



D

**Rhein-Nadel Automation GmbH**

Reichsweg 19/42 • D - 52068 Aachen  
Tel (+49) 0241/5109-159 • Fax (+49) 0241/5109-219  
Internet [www.rna.de](http://www.rna.de) • Email [vertrieb@rna.de](mailto:vertrieb@rna.de)

**Rhein-Nadel Automation GmbH**

Zweigbetrieb Lüdenscheid  
Nottebohmstraße 57 • D - 58511 Lüdenscheid  
Tel (+49) 02351/41744 • Fax (+49) 02351/45582  
Email [werk.luedenscheid@rna.de](mailto:werk.luedenscheid@rna.de)

**Rhein-Nadel Automation GmbH**

Zweigbetrieb Ergolding  
Ahornstraße 122 • D - 84030 Ergolding  
Tel (+49) 0871/72812 • Fax (+49) 0871/77131  
Email [werk.ergolding@rna.de](mailto:werk.ergolding@rna.de)

CH

**HSH Handling Systems AG**

Wangenstr. 96 • CH - 3360 Herzogenbuchsee  
Tel (+41) 062/95610-00 • Fax (+41) 062/95610-10  
Internet [www.rna.de](http://www.rna.de) • Email [info@handling-systems.ch](mailto:info@handling-systems.ch)

GB

**RNA AUTOMATION LTD**

Hayward Industrial Park  
Tameside Drive, Castle Bromwich  
GB - Birmingham, B 35 7 AG  
Tel (+44) 0121/749-2566 • Fax (+44) 0121/749-6217  
Internet [www.rna-uk.com](http://www.rna-uk.com) • Email [rna@rna-uk.com](mailto:rna@rna-uk.com)

E

**Vibrant S.A.**

Pol. Ind. Famades C/Energia Parc 27  
E - 08940 Cornellà Llobregat (Barcelona)  
Tel (+34) 093/377-7300 • Fax (+34) 093/377-6752  
Internet [www.vibrant-rna.com](http://www.vibrant-rna.com) • Email [info@vibrant-rna.com](mailto:info@vibrant-rna.com)

CAN

**RNA Automated Systems Inc.**

P.O.Box 560, Paris, Ontario, Canada, N3L 3T6  
Tel (+1) 905/3368429 • Fax (+1) 905/3191252  
Email [sales@rna-can.com](mailto:sales@rna-can.com)