

# **Operating Instructions**

## **Modular control units**

**ESM 906**  
**ESM 910**

## 1.1 Functional description

The modules dose the power at the vibrating magnets through phase angle without further control. The setting of power is done with a potentiometer, analogue reference 2 to 10 Volt DC or analogue constrained-current operation 0 to 20 mA. The aforementioned reference value allows line lengths of more than 10 meters, otherwise the max length of the line is 3 m. When operating between heavy interference centres, the control wires should be shielded.

The output voltage for the smallest reference values 0 Volt (potentiometer at the left catch) can be selected with the trimming potentiometer between 0 and 90 Volt (eff.) The highest output voltage at the reference vale 100 % can be set with the trimming potentiometer U-max between 150 and 220 Volteff.

An enable input allows the module to be switched on and off wattless. Enable can be done with a normally open contact or voltage signal 12.....24 Volt DC. The connections for the reference value and enable are free from the mains potential.

Pins 19 and 20 are made available for the operating mode. If these pins are bridged, the module is working on symmetric full wave. The vibration is then working with double the mains frequency. A missing connection leads to an asymmetric half wave, so that the vibrating drive is working on the mains frequency.

The fuses are accessible from the front panel. It is a microfuse 5x20 mm. The value for the module ESM 906 is 10 A super quick. **This fuse is only to protect the internal semiconductor. An overload fuse to**

**protect the complete unit has to be done external (i=6A).**

The module ESM 910 has now own fuse, but it has a short-circuit-proof on the main power supply unit. The modules are provided with a fixed preset soft start.

### Set-up

The modules have, at the left side wall, a heat dissipation plate for the power semiconductor. Therefore it is necessary to have a free space of a least 50 mm to the next appliance for heat dissipation.

## 1.2 EC Conformity/CSA Conformity

The control unit complies with the following regulations:

**EC - EMC Directive 89/336/EEC**  
**EC Low voltage equipment directive (73/23/EEC)**

Applied harmonised standards:

**EN 60204 T.1**  
**EC - EMC Directive EN 50081-1**  
**EN 50011, Limit value class B**  
**EC - EMC Directive EN 50082**

Applied national technical specifications:

**BGV - A2**

## 1 Types et caractéristiques

Type	Mains Voltage and power	RNA item no.
ESM 906	110 V +6% -10%; 50/60 Hz; max 6 A load current	31007099
ESM 906	230 V +6% -10%; 50/60 Hz; max 6 A load current	31007097
ESM 910	110 V +6% -10%; 50/60 Hz; max 10 A load current	31007100
ESM 910	230 V +6% -10%; 50/60 Hz; max 10 A load current	31007098

Type	ESM 906	ESM 910
Load voltage	0...220 V (0...105V)	
Output current	0...6 A	0...10 A
Set value	Potentiometer 10 kΩ; 0...10V DC or 0...20 mA DC	
Enable input	Potential free contact / 12...24 V DC, Ri 10 kΩ	
Ambient temperature	0...45°C	
Protection	IP 20	
Applied standards	EN 50081-2; EN 50082-2; VDE 0160; VBG 4	

## 2 Safety Instructions

It is always necessary to read and understand the safety instructions. This ensures that valuable material is not damaged and injuries are avoided.

Steps must be taken to ensure that all persons working with this control unit are familiar with the safety regulations and observe them.

The device described in this manual is a control unit for operating RNA bowl feeders and linear feeders. The limit values specified in the technical data must be observed.



### Note!

This hand indicates tips on operation of the control unit.



### Attention!

This warning triangle indicates safety instructions. Failure to heed this warning can lead to severe injuries or death!



Work on electrical equipment of the machine/plant may be carried out only by a trained electrician or by untrained persons under the leadership and supervision of a trained electrician in accordance with the regulations for electrical engineering!

All safety and danger signs on the machine/plant must be observed!

The electrical equipment of a machine/plant must be inspected and checked regularly. Defects such as loose connections or damaged cables must be remedied immediately!



Before commencing operation, make sure that the earthing line (power earth, PE) is intact and installed at the connecting point. Only test instruments approved for this purpose may be used for checking the safety grounding conductor.

## 3 Commissioning Instructions



Before connecting up to the mains and switching on the control unit, it is essential to check the following points:

- Is the control unit in proper working condition and closed with all screws?
- Are the connector locks clicked in/screwed secure?
- Are all cables and glands intact?
- Is PROPER INTENDED USAGE ensured?
- Does the mains voltage specification on the control unit agree with the local mains voltage?
- Does the mains frequency specification on the vibratory drive agree with the local mains?
- Is the correct operating mode set on the control unit? (See "Operating Mode" section)

Operation of the control unit may be commenced only when all questions asked above can be answered unambiguously with YES.



Before you start operation after repair work has been carried out or control units/vibrating drives have been exchanged, set the output on the control unit to minimum before switching on. Check that the system is working properly when you increase the output.

## 6 Schéma électrique

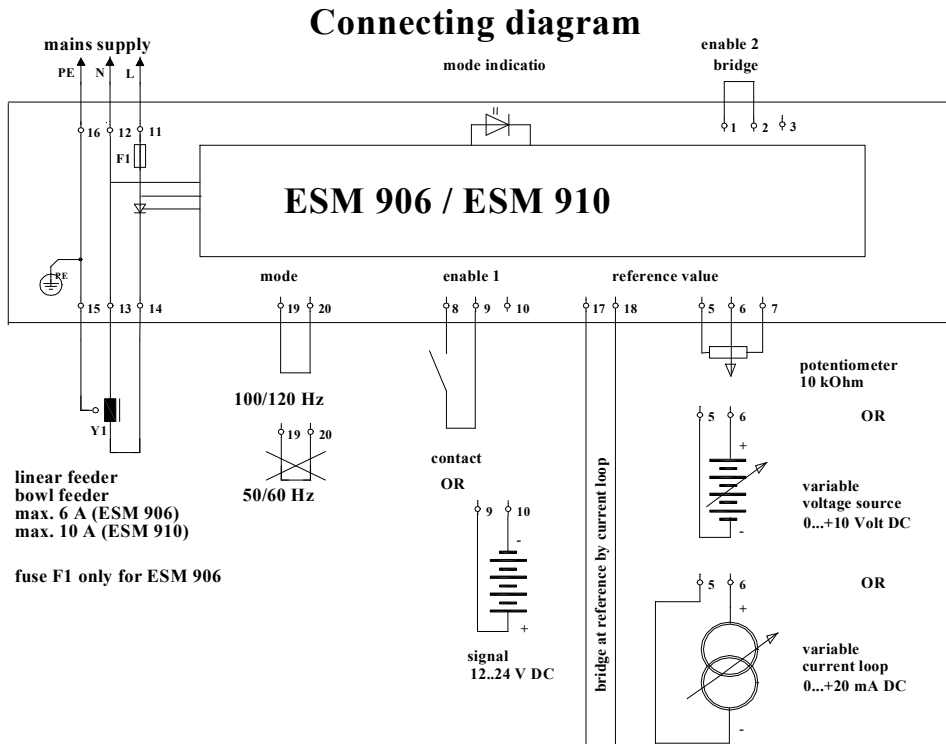

Note: The connecting diagram for the Modul ESM910 is identical. Only the two status outputs on clamp 1 upto 4 are not available. Here the clamp 1 and 2 have to bridge.

## 5 Plan dimensionnel

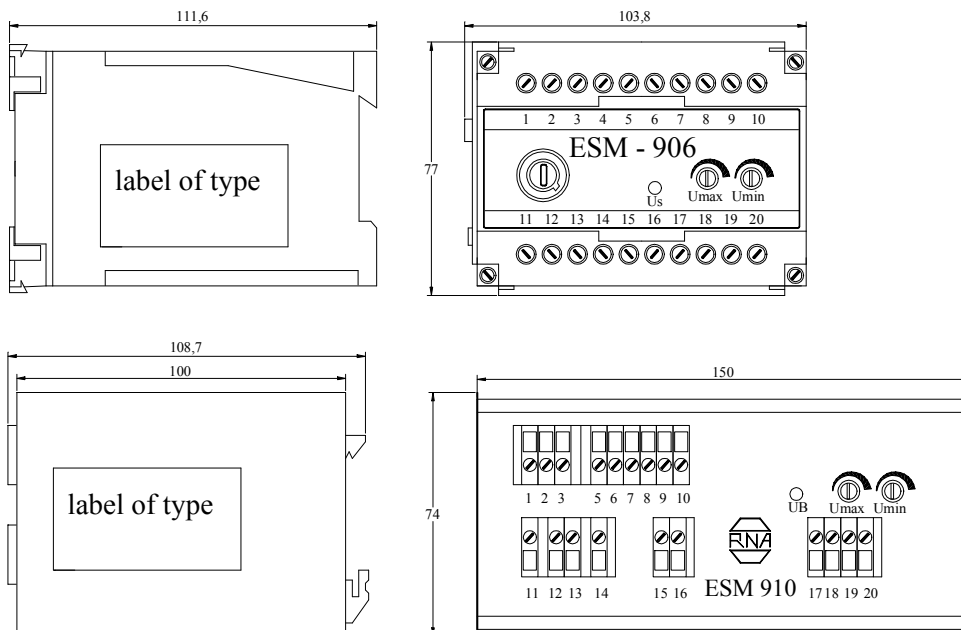



### **Rhein-Nadel Automation GmbH**

Reichsweg 19/42 • D - 52068 Aachen  
Tel (+49) 0241/5109-159 • Fax (+49) 0241/5109-219  
Internet [www.RNA.DE](http://www.RNA.DE) • Email [vertrieb@rna.de](mailto:vertrieb@rna.de)

### **Rhein-Nadel Automation GmbH**

Zweigbetrieb Lüdenscheid  
Nottebohmstraße 57 • D - 58511 Lüdenscheid  
Tel (+49) 02351/41744 • Fax (+49) 02351/45582

### **Rhein-Nadel Automation GmbH**

Zweigbetrieb Ergolding  
Ahornstraße 122 • D - 84030 Ergolding  
Tel (+49) 0871/72812 • Fax (+49) 0871/77131



### **HSH Handling Systems**

Wangenstr. 96 • CH - 3360 Herzogenbuchsee  
Tel (+41) 062/95610-00 • Fax (+41) 062/95610-10  
Internet [www.hsh-handling.ch](http://www.hsh-handling.ch) • Email [info@handling-systems.ch](mailto:info@handling-systems.ch)  
Verkaufsbüro Kurt Allemann, Dahlienstrasse 9, CH-4533 Riedholz  
Telefon (0 32) 622 03 07 • Telefax (0 32) 623 37 85



### **RNA AUTOMATION LTD**

Hayward Industrial Park  
Tameside Drive, Castle Bromwich  
GB - Birmingham, B 35 7 AG  
Tel (+44) 0121/749-2566 • Fax (+44) 0121/749-6217  
Internet [www.rna-uk.com](http://www.rna-uk.com) • Email [rna@rna-uk.com](mailto:rna@rna-uk.com)



### **Vibrant S.A.**

Pol. Ind. Famades C/Energia Parc 27  
E - 08940 Cornelia Llobregat (Barcelona)  
Tel (+34) 09/377-7300 • Fax (+34) 093/77-6752  
Internet [www.vibrant-rna.com](http://www.vibrant-rna.com) • Email [info@vibrant-rna.com](mailto:info@vibrant-rna.com)



### **RNA Automated Systems Inc.**

P.O.Box 560, Paris, Ontario, Canada, N3L 3T6  
Tel (+1) 519/442-2018 • Fax (+1) 519/442-2385  
Email [sales@rna-can.com](mailto:sales@rna-can.com)