

Operating instructions Linear feeder

SLK 05
SLK 1
SLK - N 6
SLK - N 6G
SLK 12

BA

Rhein-Nadel Automation GmbH

Contents

1	Technical data	Page 2
2	Safety instructions	Page 3
3	Construction and function of the linear feeder	Page 4
4	Transport and mounting	Page 4
5	Starting/Adjustment	Page 5
6	Specifications for the design of the track	Page 6
7	Maintenance	Page 7
8	Stockkeeping of spare parts and after-sales service	Page 7
9	What is to do, if....? Instructions for trouble-shooting	Page 7



Notice

All linear feeders listed in the table may only be operated in connection with a RNA control unit at a mains voltage of 230V/50Hz.. Special voltages and frequencies see separate data sheet.

1 Technical data

Linear feeder type		SLK 05	SLK 1	SLK-N 6	SLK-N 6 G	SLK 12
Dimensions L x W x H	in mm	210 x 50 x 86	305 x 123 x 104	410 x 162 x 143	600 x 196 x 143	515 x 203 x 164
Weight	in kg	2,8	7,8	22,3	34,2	33
Insulation type		IP 54	IP 54	IP 54	IP 54	IP 54
Connecting cable length	in m	1,5	1,5	1,5	1,5	1,5
Power consumption (1)	in VA	16	44	250	250	484
Current consumption (1)	in A	0,07	0,2	1,25	1,25	2,2
Magnet nominal voltage (1)/Frequency	in V/Hz	200 / 50	200 / 50	200 / 50	200 / 50	200 / 50
Number of magnets		1	1	1	1	1
Magnet type		WS 3 / 25	ME 1/100/120	WS 9/41	WS9/41	ME 12/50/60
Magnet colour		black	brown	red	red	brown
Air gap	in mm	0,8	1,0	2,5	2,5	3,5
Vibration frequency	in Hz/min	100 / 6.000	100 / 6.000	50 / 3.000	50 / 3.000	50 / 3.000
Number of spring assemblies		2	2	2	2	2
Standard no. of springs Number per spring assembly		1 x 1,0 1 x 1,0	1 x 3,0; 1 x 2,5 2 x 2,5	2 x 3,5 1 x 3,5; 1 x 2,0	2 x 3,5 1 x 3,5; 1 x 2,0	1 x 3,0; 1 x 3,5 1 x 3,0; 2 x 3,5
Spring dimensions Length (gauge for boreholes) x width	in mm	55(46) x 42	73(59) x 85	108(90) x 120	108(90) x 120	128(107) x 160
Spring size	in mm	0,5; 0,8; 1,0	2,5; 3,0	2,0; 3,5	2,0; 3,5	3,0; 3,5
Spring material		V2A	Plastic	Plastic	Plastic	Plastic
Quality of the spring fastening screws		8.8	8.8	8.8	8.8	8.8
Tightening moment of the spring fastening screws	in Nm	8	15	30	30	60
Max. weight of the oscillating units (linear track) depending on the mass moment of inertia and required running speed approx.kg	in kg	1,0	1,3 - 3,4	5 - 8,5	5 - 8,5	12 - 18
Max. track length	in mm	350	400	800	800	1.000
Maximum useful weight of the linear feeder	in kg	1,0	1,3 - 3,4	5 - 8,5	5 - 8,5	12 - 18

(1) At special connecting values (voltage/frequency) see type plate at the magnet

Pin assignment

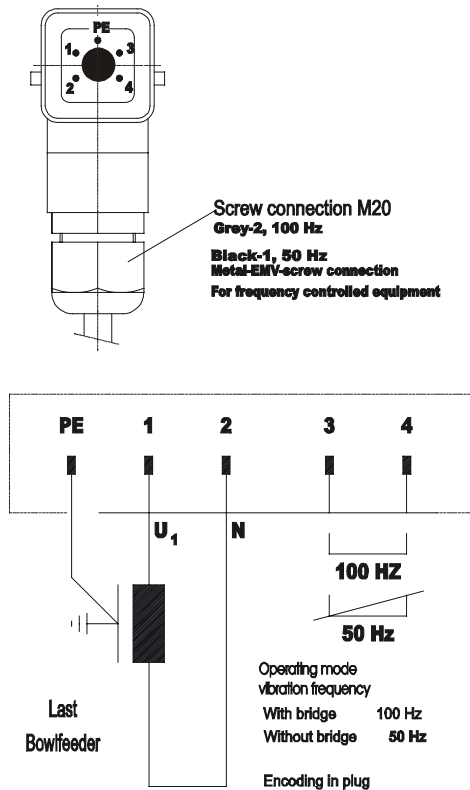

2 Safety instructions

The conception and production of our linear feeders has been carried out very carefully, in order to guarantee trouble-free and save operation. You too can make an important contribution to job safety. Therefore, please read this short operating instructions completely, before starting the machine. Always observe the safety instructions!

Make sure that all persons working with or at this machine carefully read and observe the following safety instructions!

This operating instruction is only valid for the types indicated on the front page.



Notice

This hand points to information that gives you useful tips for the operation of the linear feeder.



Attention

This warning triangle marks the safety instructions. Non-observance of these warnings can result in serious or fatal injuries!

Dangers occurring at the machine

- The most dangerous parts of the machine are the electrical installations of the linear feeder. In case the linear feeder gets wet, there is the danger of an electric shock!
- Make sure that the protector ground of the electric power supply is in perfect condition!

Intended use

The intended use of the linear feeder is the actuation of conveying tracks. These are used for linear transport and feeding of correctly positioned mass-produced parts, as well as for the proportioned feeding of bulk material.

The intended use also includes the observance of the operating and servicing instructions.

Please take the technical data of your linear feeder from the table "technical data" (see chapter 1). Make sure that the connected load of the linear feeder, control unit and power supply is compatible.



Notice

The linear feeder may only be operated in perfect condition!

The linear feeder may not be operated in the explosive or wet area.

The linear feeder may only be operated in the configuration drive unit, control unit and oscillating unit, as specified by the manufacturer.

No additional loads may act upon the linear feeder, apart from the material to be transported, for which the special type is designed.



Attention

It is strictly prohibited to put any safety devices out of operation!

Demands on the user

For all activities (operation, maintenance, repair, etc.) the details of the operating instructions must be observed.

- The operator must avoid any working method which would impair the safety of the linear feeder.
- The operator must take care that only authorized personnel works at the linear feeder.

- The user is obliged to inform the operator immediately about any changed conditions at the linear feeder that could endanger safety.



Attention

The linear feeder may only be installed, put into operation and serviced by expert personnel. The binding regulation for the qualification of electricians and personnel instructed in electrical engineering is valid, as defined in IEC 364 and DIN VDE 0105 part 1.



Attention:

Since the electromagnetic-field may have an impact on persons carrying pacemakers it is recommended to keep a minimum distance of 25 cm.

Noise emission

The noise level at the place of operation depends on the complete equipment and the material to be transported. The determination of the noise level according to the EC-Regulations "Machinery" can therefore only be carried out at the place of operation.

If the noise level at the place of operation exceeds the limit permitted, noise protection hoods may be used, which we offer as accessory parts (see catalogue).

Standards and regulations

The device was built according to the following standards and regulations:

- EC- Directive Machinery 98/37/EC
- EC- Low voltage directive 73/23/EC
- EMC- Directive 89/336/EC
- Applied harmonized Standards
EN 60204, T.1
EN 292, T.1 and T.2
- Applied national technical standards
VGB 4
VGB 10
- Rheinnadel- Conditions for purchasing
- VDE- Standards
- VDMA- Conditions of delivery

3 Construction and function of the linear feeder

Linear feeders are used for the actuation of conveying equipments. The actuation takes place by an electromagnet. The following

schematic diagram shows the function of a linear feeder:

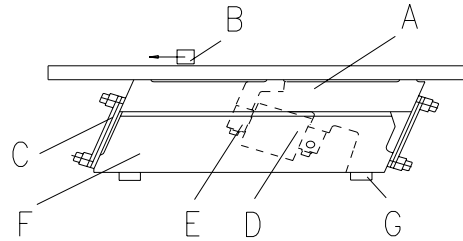

- | | | | |
|---|--|---|-----------------|
| A | Conveying track and oscillating weight | C | Spring assembly |
| B | Material to be conveyed | E | Armature |
| D | Drive magnet | F | Counter-mass |
| F | Counter-mass | G | Shock absorber |

The linear feeder is a device of the family of vibratory bowl feeders. It is, however, equipped with a linear conveyor. Electromagnetic vibrations are converted into mechanical vibrations and are used for conveying material B. If magnet D, which is fixedly connected with the counter-mass F, is supplied with current, it generates a power that, dependent on the vibration frequency of the mains supply, attracts and releases armature E. Within a period of the 50 Hz of the A.C. network the magnet achieves its maximum power of attraction twice, as this is independent of the direction of the current conduction. The vibration frequency therefore is 100 Hz. In case a half-wave is locked, it is 50 Hz. Please take the vibration frequency of your linear feeder of the table "technical data" in chapter 1.

A linear feeder is a resonant system (spring-mass-system). The result is that the adjustment made at the factory will rarely meet your requirements. Chapter 5 describes in detail how your linear feeder is adapted to your requirements.

Controlling of the linear feeder takes place by a low loss electronic control unit type ESG N 80 or type ESG 90. The control unit of the linear feeder is separately delivered. At its front panel it is provided with a 7-pole plug-in connection, by which it is connected to the linear feeder.

The pin assignment of the socket is shown in the table "technical data" (chapter 1).



Notice

Detailed information on the complete range of control units may please be taken from the operating instructions for control units.

All control units have got two main operating elements:

- By the **mains switch** the linear feeder is switched on or off.
- By the **turning knob** the conveying capacity of the transport unit is set.

4 Transport and mounting

Transport



Notice

Take care that the linear feeder cannot dash against other things during transport.

The weight of the linear feeder is please taken from the table "technical data" (chapter 1).

Mounting

The linear feeder should be mounted on a stable substructure (available as an accessory part) at the place where it is used. The substructure must be dimensioned in a way that no vibrations of the linear feeder can be carried away.

Linear feeders are fastened to the shock absorbers from below (part G in the general drawing chap. 3). The following table will give you a summary of the bore data of the various types:

Linear feeder type	Length in mm	Width in mm	Shock absorber thread
SLK 05	180	35	M4
SLK	200	70	M4
SLK-N6	270	100	M6
SLK-N 6 G	270	100	M6
SLK 12	345	140	M6

Table bore data

Make sure that the linear feeder cannot come into contact with other devices during operation.

Further details on the control unit (bore plan, etc.) are please taken from the operating instructions of the control unit separately delivered.

5 Starting



Notice

Ensure that the frame (stand, base, frame etc.) is connected with the ground wire. (PE) If necessary, predetection earthing on spot should be provided.



Notice

Ensure that the frame (stand, base, frame etc.) is connected with the ground wire. (PE) If necessary, predetection earthing on spot should be provided.

Preparations



Notice

Ensure that the frame (stand, base, frame etc.) is connected with the ground wire. (PE) If necessary, predetection earthing on spot should be provided.

Check, whether

- the linear feeder stands in an isolated position and does not come in contact with a solid body
- the linear track is fixedly screwed down and adjusted
- the connecting cable of the linear feeder is plugged in at the control unit.



Attention

The electric connection of the linear feeder may only be made by trained personnel (electricians)! In case modifications are made at the electric connection, it is absolutely necessary to observe the operating instructions "control units".

- The available supply voltage (frequency, voltage, output) is in accordance with the connection data of the control unit (see type plate at the control unit).

Plug in the mains cable of the control unit and switch on the control unit by the mains switch.



Notice

At linear feeders which are delivered as a completely adjusted system, the optimal conveying capacity is already set at the factory. It is marked on the scale of the turning knob with a red arrow. In this case set the turning knob to the marking.

The optimal operative range of the linear feeder is at a controller position of 80% at the control

unit. In case of higher deviations ($\geq \pm 15\%$) a readjustment should be carried out.

Adjustment of the running behaviour



Notice

At first a rough adjustment of the conveying speed (adjustment of the natural frequency) must be made, which is followed by the adjustment of the running behaviour. Finally you adjust the conveying speed (natural frequency).

At linear feeders without counterweight the running speed at the discharge side is always higher than at the feeding side. This is recognized by the vertical amplitude of the conveying track, which is higher at the discharge side. By attaching a counterweight this speed difference can be seen. The counterweight increases the countermass of the linear feeder and can be installed according to the following sketch:

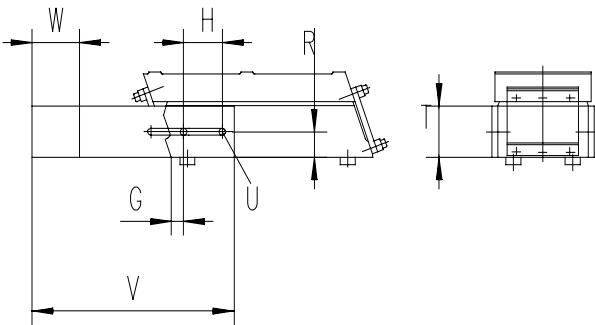

Type	SLK1	SLK-N6	SLK12
G	10	20	10
H	45	65	2x50
R	24	40	40
T	40	80	80
U	M8	M10	M10
V	200	340	390
W	40	80	80

The size of the weight must be determined in a test. The linear feeders type SLK 05 and SLK-N6G are already equipped with a counterweight in the factory.

During the adjustment of the conveying track to a steady running speed the following must be carried out:

- If the vertical amplitude on the conveying track is higher at the discharge side than on the feeding side, a counterweight must be installed or the existing counterweight in the

longholes must be completely drawn to the outside. With SLK 05 additional weight plates have to be fitted. In case this is not sufficient, an additional counterweight must be mounted.

- If the vertical amplitude at the discharge side is lower than at the feeding side, with a counterweight already mounted, the procedure is vice versa.

Adjustment of the natural frequency

In case the linear feeders are delivered without track, they have been adjusted in the factory to average weights of the oscillating elements. In order to guarantee an optimal conveying behaviour, the linear feeder must be adjusted to the definite operating conditions.

The adjustment is made by adding or removing leaf springs and washers.

First check, whether the right control unit (frequency, voltage, power supply, (see table "technical data" in chapter 1) has been connected.

Carry out the following steps:

- Tighten all spring fastening screws and track fastening screws. Please take the tightening moments of the spring fastening screws from the table technical data (chapter 1).
- Check, whether the magnet corresponds to the specifications in the "technical data" (voltage, frequency).
- Measure the magnet-air gap. In case it differs from the specifications in the "technical data", adjust it correctly.
- Fill the tracks with material to be conveyed and turn the turning knob of the control unit to 90 % of the conveying capacity.
- Loosen a fastening screw at one of the spring assemblies (approx. 1/4-1/2 rotation).

In case the difference in the running speed is not recognized during loosening of the first screw, a further lower fastening screw must slowly be loosened.

While the spring fastening screw is loosened, you can see a change in the conveying speed.

The following graphic chart shows the resonance curve of a linear feeder:

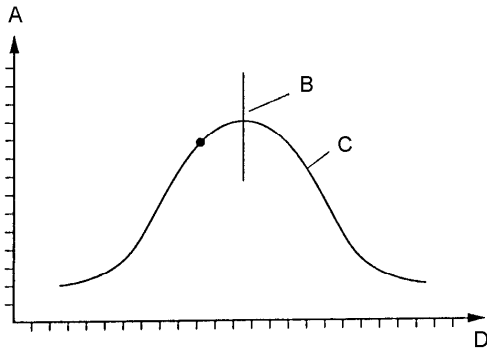

- A Conveying speed
 B Resonant frequency of the system
 C Resonance curve (not true to scale)
 D Spring power



Notice

The resonant frequency of the linear feeder may not correspond to the mains frequency.

In case the conveying capacity decreases after loosening the spring fastening screw, proceed as described under point 5.1.

In case, however, the conveying capacity, increases, proceed as described under point 5.2.



Notice

The adjustment is, however, more easy by using an electronic frequency converter, which you can buy from our range of accessory parts

The linear feeder should be adjusted that the required conveying capacity is achieved at a controller position of approx. 80% at the control unit.

5.1 The conveying speed decreases?

Mount additional springs (with distance plates). Start with one additional spring (with washer) at one spring assembly. Start with one additional spring at one spring assembly. In case the conveying speed still decreases, although an additional fastening screw is loosened, install one additional spring with washer at the second spring assembly (one after the other). When using springs of different size, it must be taken care that always the thinnest spring closely fits to the contact surface.

5.2 The conveying speed increases?

Remove the springs (with washers). First remove one spring from one spring assembly. In case the conveying speed still increases, although an additional fastening screw is loosened, remove further springs (one after the other).

When installing additional springs it must be taken care that the thread reach of the spring fastening screws corresponds to the 1.5-2-fold of the screw diameter. The tightening torque of the spring fastening screws is please taken from the "technical data" (chap. 1).



Notice

At a turning knob position of 100 % at the control unit and correctly adjusted magnetic gap the magnet may not dash against the armature when switching on the device. In case this is the case, proceed as described under point 5.2. (remove springs)

The aim of the adjustment is:

If the required conveying speed is achieved at a controller position of 80 %, the conveying speed must always decrease when the spring fastening screw is loosened.



Notice

Take care that 1/3 of the spring power is mounted at the feeding side and 2/3 of the spring power at the discharge side. Adjustment of the linear feeder type GL 01:

The spring power of a spring increases with the square of its thickness. A 3.5 mm spring eg. has a similar spring power as a combination of two springs at 2 mm thickness and two springs at 1.5 mm thickness; a 4 mm spring corresponds to a combination of four springs at 2 mm thickness.

6 Specifications for the design of the track

The projection of the track in longitudinal direction towards the vibrator should be at a ratio of **1/3 feeding side to 2/3 discharge side**.

The tracks must be of solid construction. upright beams with a high moment of resistance should be preferred (U-beams, rectangular tubes, etc.). Especially tracks for thin material as eg. stamped metal parts, etc. should be manufactured with the greatest possible clearance between material to be conveyed and cover. Here it must, however, be guaranteed that the material to be conveyed does not run one piece on top of the other or becomes wedged together.

The track should be located in the middle of the vibrator. Tracks projecting over the vibrator on one side must if necessary be provided with counterweights.

7 Maintenance

The linear feeders are generally maintenance-free. They should, however, be thoroughly cleaned in case they are considerably dirty or after fluids have been spilled over them.

- For that first unplug the mains plug.
- Clean the inside of the linear feeder, especially the magnetic gap.
- After the mains plug has been plugged in, the linear feeder is ready for operation again.

8 Stockkeeping of spare parts and after-sales service.

The range of the spare parts available may be taken from the separate spare parts list. In order to guarantee quick and faultless handling of the order, please always state the type of equipment (see type plate), number of pieces needed, spare part name and spare part number.

You will find a list of our service addresses on the back page of the cover.

9 What is to do, if... (Instructions for trouble-shooting)

**Attention**

The control unit or the connecting terminal box may only be opened by an electrician. Before opening the a.m. devices, the mains plug must be unplugged!

Trouble	Possible cause	Remedy
Linear feeder does not start when being switched on	Mains switch off Mains plug of the control unit is not plugged in Connecting cable between linear feeder and control unit is not plugged in Fuse in the control unit defective	Switch on the mains switch Plug in the mains plug. Plug in the 7-pole plug at the control unit Replace the fuse
Linear feeder vibrates slightly 	Turning knob at the control unit is set to 0% Wrong vibration frequency Attention: in case a linear feeders SLK 05 and SLK1 are operated without a bridge in a 7-pole plug, the control unit and the magnet is in danger!	Set the controller to 80%. Check, whether the code in the plug of the linear feeder is correct (see type plate and "technical data" (chap. 1)
After a longer operating time the linear feeder does no longer come up to the conveying capacity required	Fastening screws of the linear track have worked loose Screws at one or two spring assemblies have worked loose Magnetic gap misadjusted Springs are broken	Retighten the screws. Tighten the screws (tightening torques see "technical data" (chapt. 1) Replace the broken springs
Linear feeder produces loud noise	Foreign bodies in the magnetic gap	Switch off the linear feeder and remove the foreign bodies, after that check the magnetic gap adjustment
Linear feeder cannot be adjusted to a constant conveying speed	The spring constant of the oscillating system has changed. The linear feeder works close to the resonance point	Readjust the linear feeder. Springs must be removed. See chapt. 5, adjustments

