



Operating Instructions

Control Units for Oscillating Drives

ESR 2500 / 2800

1	Introduction	3
2	General	5
3	Safety Regulations and General Warnings	7
4	Installation	9
5	Operation	14
6	Technical Data	24
7	Alarms	25



Declaration of Conformity

in terms of the Low Voltage Directive 2006/95/EC
and the EMC Directive 2004/108/EC

We herewith declare that the product is in conformity with the following provisions:
Low Voltage Guideline 2006/95/EC
EMC Directive 2004/108/EC

Applied harmonised standards: DIN EN 60204 T1
 EN 60439-1

Comments:

Rhein-Nadel-Automation

Managing Director
Jack Grevenstein



1 Introduction

1.1 Field of application

The control units of the ESR2500/2800 series are output regulators and frequency controllers for RNA vibratory and linear feeder drives.

This document describes the operation, technical data and installation procedure of the ESR 2500/2800 models and their accessories offered in this product line.

1.2 Functional Description

This fully automatic control unit was developed to operate a bowl feeder or linear feeder.

The intelligent control system continuously checks the mechanical vibration of the feeder and uses this signal to actively regulate the oscillation amplitude whilst making sure that the vibration stays exactly at the preset amplitude, regardless of the conveyed load, ambient temperature and mains frequency, etc.

The frequency of the drive voltage is automatically regulated in a PLL control circuit, so that the feeder is always operated under optimum conditions, i.e. exactly in the resonant range.

The control system adapts itself to the specific feeder via an automatic fine-adjustment process, through which the often laborious procedure of mechanical adjustment ceases.

With these control units, vibratory bowl feeders with different mains frequencies can be operated without having to change the magnets or having to be adjusted mechanically.

The control system has a self-protection which ensures that neither the conveyor magnets nor any other components become overloaded. The operating parameters of all mechanical and electrical components are constantly monitored. In the event of larger deviations, the monitoring function triggers alarm signals before any serious consequences happen, i.e. it identifies defective springs or loose nuts before any damage can occur.

In this control system, there are two sensor amplifiers with 24V DC.

In addition, there are two optocouplers and a relay output for status messages as well as an external enable input with 24V DC for the remote control.

1.3 Standard Features

- Dynamic electronic protection designed for output short circuits and output overloads.
- Active protection of the magnets and feeder.
- Permanently regulated speed that ensures stable operating behaviour as well as a recursive speed adjustment.
- The feeder requires less maintenance.
Since the frequency is automatically adjusted to the changes in the conveying properties, this reduces the necessity of frequent fine adjustments on the feeder's springs.
- Less electricity consumption (around 50%).
Less electricity is needed to operate the feeder when it runs in the resonant range.
- Flexible choice of frequency of resonance (25-150 Hz).
The conveyor resonance can be finely tuned to an optimal frequency for a certain application without taking into account the mains frequency.
- Independent when there are mains fluctuations (volts / freq.).
- Control over the entire feeding system.
- Two sensor amplifiers.
 - Two independent 24V DC remote control inputs to control the feeding installation (accumulation monitoring).
- Speed control through analog input.
- Communication features (additional connection required).
 - 24V electrically isolated input for the Start/Stop control.
 - "Ready for Operation" message (optocoupler, 24VDC, 20mA).
 - Active message (optocoupler, 24VDC, 20mA).
 - Active message via relay contact. 250 V AC 1 Amp.
- Mains connection performance after mains connection.
- Firmware upgrade over USB connection.

1.4 Optional Features (in preparation)

- Immediate Stop function by using the active brake control. This option stops the feeder immediately when a Stop order is given, i.e. contrary to the resonance dying away on its own, it prevents the vibratory drive from "coasting".
This option is especially useful when applying counters, i.e. when an exact number of parts has to be counted without that surplus or undesired parts fall from the feeder after the correct number of pieces has been counted.
- Multiple calibration. Here, the control system can be used with a series of up to eight different feeders without having to readjust every time.
- As an option, there is a 24V electrically isolated control input for the change between different speed levels.
- Alarm signals (voltage-free contact).
- Fieldbus (additional module required).
 - PROFIBUS DPV1.

2 General

2.1 Overview Operating Instructions

The ESR2500 / 2800 control system was developed for a high vibratory performance for all RNA feeders. To handle the control system correctly, please read through this manual carefully. Incorrect handling of the vibratory control can lead to trouble in the control system, reduce its life or cause other errors.

These operating instructions will help you with the installation, programming and troubleshooting your vibratory control.

Chapter 1, **Introduction**, describes the functions and features of the vibratory control.

Chapter 2, **How to Read these Operating Instructions**, introduces this manual and informs you about the approvals, symbols and abbreviations used in it.

Chapter 3, **Safety Regulations and General Warnings**, contains instructions about how to operate the vibratory control correctly.

Chapter 4, **Installation**, describes the mechanical and electrical installations.

Chapter 5, **Operation**, shows how the vibratory control is operated and programmed over the control panel.

Chapter 6, **General**, contains technical data about the vibratory control.

Chapter 7, **Alarms**, helps when solving problems that may arise whilst using the vibratory control.

Available documentation for the vibratory control type ESR 2500 / 2800

The operating instructions for ESR2500 / 2800 provide the necessary information to put the drive into operation.

(Option in preparation)

The Profibus operating instructions for the type ESR2500 / 2800 provide the necessary information for the control system, monitoring and programming of the vibratory control over the Profibus fieldbus.

2.2 Applied Standards

EC Conformity

The control unit complies with the following regulations:

**EC EMC Directive 2004/108/EC;
EC Low Voltage Guideline
2006/95/EC**

Applied harmonised standards:

**DIN EN 60204, T.1
EN 60439-1**

2.3 Symbols

The symbols used in these operating instructions:



Caution!
This warning triangle indicates safety regulations.
Failure to observe this warning can lead to serious injuries or death!



This hand shows the reader (operator) what he must be aware of.

* This symbolises a standard adjustment.

2.4 Abbreviations

Alternating current	AC
Ampere/AMP	A
Direct current	DC
Electromagnetic compatibility	EMC
Hertz	Hz
Local control panel	LCP
Millisecond	ms
PLL circuit	PLL
Printed circuit board	PCB
Second	s
Volt	V
Watt	W

3 Safety Regulations and General Warnings

It is absolutely necessary to read and to understand the safety regulations. This ensures that valuable material is not damaged and prevents injuries.

It must be guaranteed that all persons working with this control unit know and observe the safety regulations.

The control unit described in this manual is for operating the RNA sorting and linear feeders.

The limiting values indicated in the technical data must be observed.



Work on the electrical equipment / machines / installation may only be carried out by a specialised electrician or by a person instructed in electrotechnology under the direction and supervision of a qualified electrician in accordance with the regulations of electrical engineering.

All safety and warning signals on the machine/installation must be observed!

The electrical devices of a machine/installation have to be checked and controlled regularly. Defects like loose connections or damaged cables must be eliminated immediately!



Before starting operation, please make sure that the safety earthing is intact and installed at the point of connection. Only testing instruments approved for this purpose are allowed to be used to test the safety earthing connection.



Caution!

The DC connection capacitors of the vibratory control remain loaded after switching off the power. To prevent the risk of an electric shock, switch the control system off from the mains before maintenance work and wait at least as long as indicated below.

ESR 2500

10 minutes

ESR 2800

15 minutes

3.1 Instructions for Putting into Operation



The connecting cable between the control unit and the vibratory bowl feeder must be shielded, and the sheath must be connected on both ends to the safety earthing line. The maximum permissible cable length is 3 m.



Before the control unit is connected to the mains and switched on, it is absolutely necessary to check the following points:

- Is the control unit in a good, safe operational condition and closed with all screws?
- Are the connection locks blocked/screwed down?
- Are all the cables and screw fittings intact?
- Is the INTENDED USE guaranteed?
- Does the indicated mains voltage on the control unit tally with the local mains voltage?

The control unit may only be put into operation when all the questions asked above can definitely be answered with YES.



Before starting with the operation after maintenance works or after changing the control units/vibratory control, set the power output to minimum before switching on. Check whether the system functions correctly when you raise the power output.



Before opening the control unit, pull the mains plug and wait for as long as indicated below, so that the capacitor load can phase out.

Discharging time:

ESR 2500

10 minutes

ESR 2800

15 minutes

3.2 Operating Mode

To prevent any mechanical and / or electrical damage on the ESR 2500 / 2800 control system or connected units, the parameters listed under point 4.2 must be strictly observed. If you do not find your certain type of drive unit listed in the table, please contact "Rhein Nadel Automation". We will be glad to assist you.



To make sure that the drive unit runs in a quiet and stable manner, it is important to use a well-tuned drive. Please refer to the manuals on drive units to find out how the springs have to be adjusted.

4. Installation

This chapter deals with the mechanical and electrical installation of the power and control connections.

4.1 Course of Putting into Operation

The vibratory control is designed to enable quick and unproblematic installation by following the steps described below:



Read the safety regulations before installing the unit.

Mechanical installation

- Mechanical assembly

Electrical installation

- Connection to the mains and protective earthing,
- Vibratory connections and cables,
- Cable for the control connection.

Adjustment

- Calibration
- Programming

4.2 Preinstallation

Planning the place of installation



Before starting with the installation, it is important to plan the installation of the control system and vibratory bowl feeder. If this is not done, it could lead to more work during and after installation.

Choose the best possible position by taking the following into account:

- Ambient temperature
- Method of installation
- How the unit is to be controlled
- Position of the control system
- Cable layout

4.3 Mechanical Installation

Mechanical dimensions

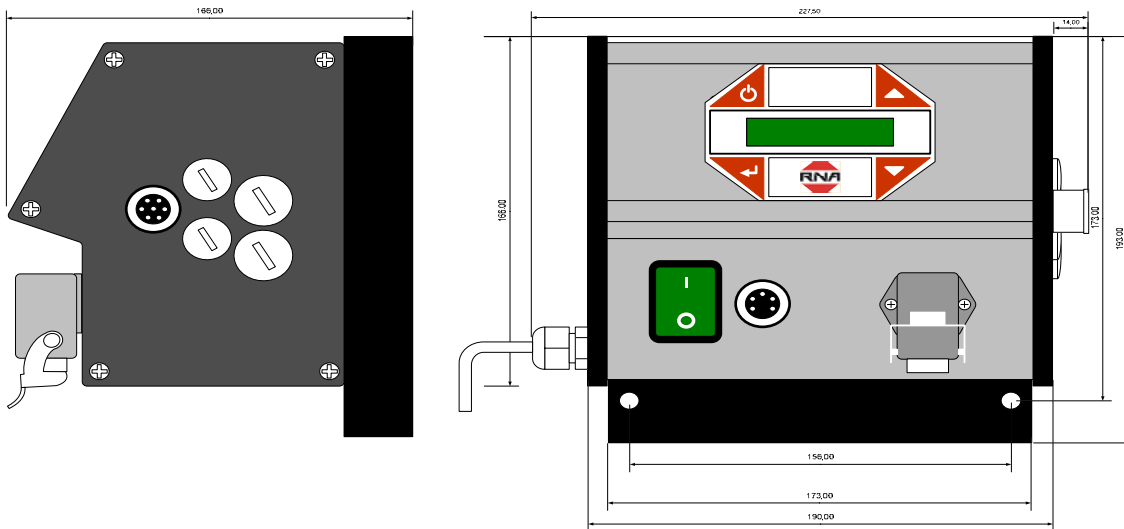

Mechanical installation

The ESR2500 / 2800 control system is mounted with two M8x40mm screws through two holes in the heat sink under the casing.

The unit can be mounted either directly onto the base plate of the feeder or onto the base frame of other machines.

By mounting the control system directly onto the feeder, it is exposed to strong vibrations which can shorten its life. It is, therefore, strongly recommendable to mount the control system onto a non-vibrating, mechanically stable structure like e.g. onto the base frame of a machine.

4.4 Electrical Installation

Fuses

The unit is protected internally by a 4A 5x20mm time-lag fuse in the mains supply line.

The mains connection has to be protected over an overload protection with a C 16A fuse.

Earthing and Mains



Check whether the mains voltage is identical with the information on the rating plate of the unit.

The ESR2500 / 2800 controls are units of class protection 1 that have to be earthed according to the regulations.

Connecting the vibratory bowl feeder

To achieve an optimum performance, the maximum load current of the vibratory bowl feeder has to be set according to Table 1 "Connection table for max. current setting S301".

Information about the maximum current for the feeders can be found on the rating plate on the vibratory bowl feeder drive.

Current setting	2500	2800	S301-1	S301-2	S301-3	S301-4	S301-5
100%	5.53 A*	9.00 A*	X01-1(L)	S301-3	S301-2	NC	X01-2(N)
50%	2.75 A	4.50 A	X01-1(L)	NC	S301-4	S301-3	X01-2(N)
33%	1.83 A	3.00 A	S301-3	X01-1(L)	S301-1	NC	X01-2(N)
25%	1.37 A	2.25 A	NC	X01-1(L)	S301-4	S301-3	X01-2(N)

Table 1 – Connection table for max. current setting S301

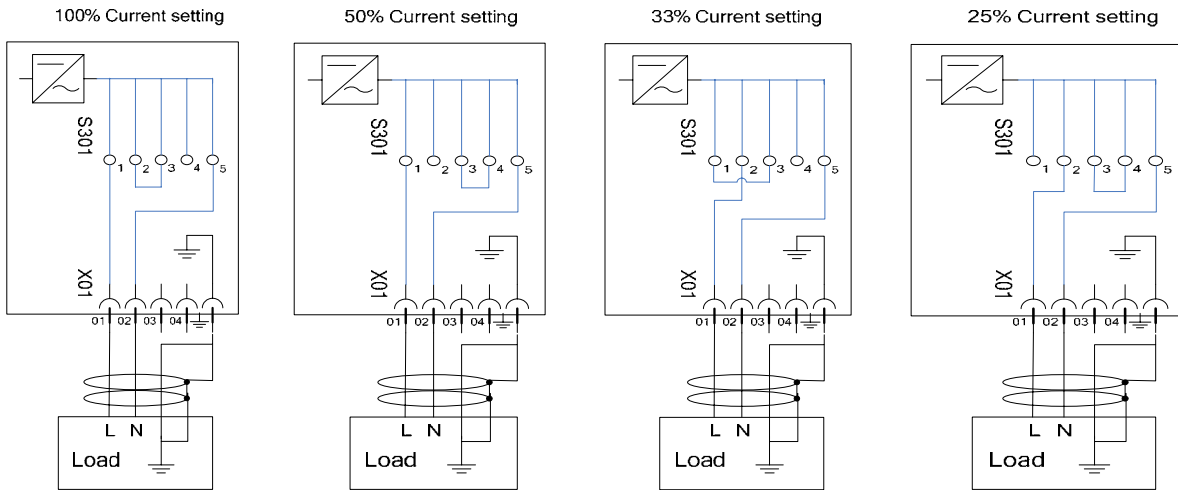

Bowl feeder's drive system	Max. Current[A _{eff}]	Max. Magnetic gap(mm)	Frequency range	Magnet colour
SRC - N 160 - 2	0.6	0.5	90...120 Hz	Black
SRC - N 200 - 2	1.2	0.5	90...120 Hz	Black
SRC - B 200 - 2	1.2	0.5	90...120 Hz	Black
SRC - N 250 - 2	2.6	1.2	90...120 Hz	Black
SRC - B 250 - 2	2.8	1.2	90...120 Hz	Black
SRC - N 400 - 1	3.8	2.8	45...60 Hz	Red
SRC - N 400 - 2	4.3	1.2	90...120 Hz	Black
SRHL - 400 - 1	5.7	2.8	45...60 Hz	Red
SRHL - 400 - 2	5.3	1.5	90...120 Hz	Black
SRC - N 630 - 1	5	2.8	45...60 Hz	Red
SRC - N 800 - 1	8,5	2.8	45...60 Hz	Red

Table 2 – RNA bowl drives

Linear feeder's drive system	Max. Current [A _{eff}]	Max. Magnetic gap(mm)	Frequency range	Magnet colour
SLL 175	0.07	0.8	90...120 Hz	Black
SLL 400	0.6	1	90...120 Hz	Black
SLL 800	1.4	3	45...60 Hz	Red
SLL 804 < 1600	1.4	3	45...60 Hz	Red
SLL 804 ≥ 1600	2.8	3	45...60 Hz	Red
SLF 1000	2.8	2.5	45...60 Hz	Red
SLF 1500	5.6	2.5	45...60 Hz	Red
GL 01	0.6	1.0	90...120 Hz	Black
GL 1	1.1	1.2	90...120 Hz	Black
SLK N6	1.4	2.5	45...60 Hz	Red
SLK N6 G	1.4	2.5	45...60 Hz	Red

Table 3 – RNA linear feeders

4.5 Control connections

Sensor inputs and sensor connections

The control unit has two sensor inputs that can be used for checking the conveyor media (accumulation monitoring) and other monitoring functions. Two sensors of the types NPN and PNP can be connected. Fig. 1 “Passive Optical Sensor” shows how an optical sensor is connected to Sensor Input 1, and Fig. 2 “Proximity Switch” shows how a proximity switch is connected to Sensor Input 1. Two sensors can be connected by means of a cable distributor, as is shown in Fig. 3.

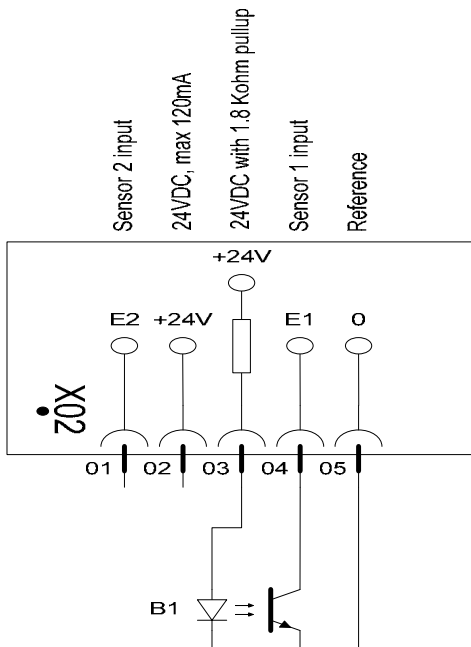

Fig. 1 Passive Optical Sensor

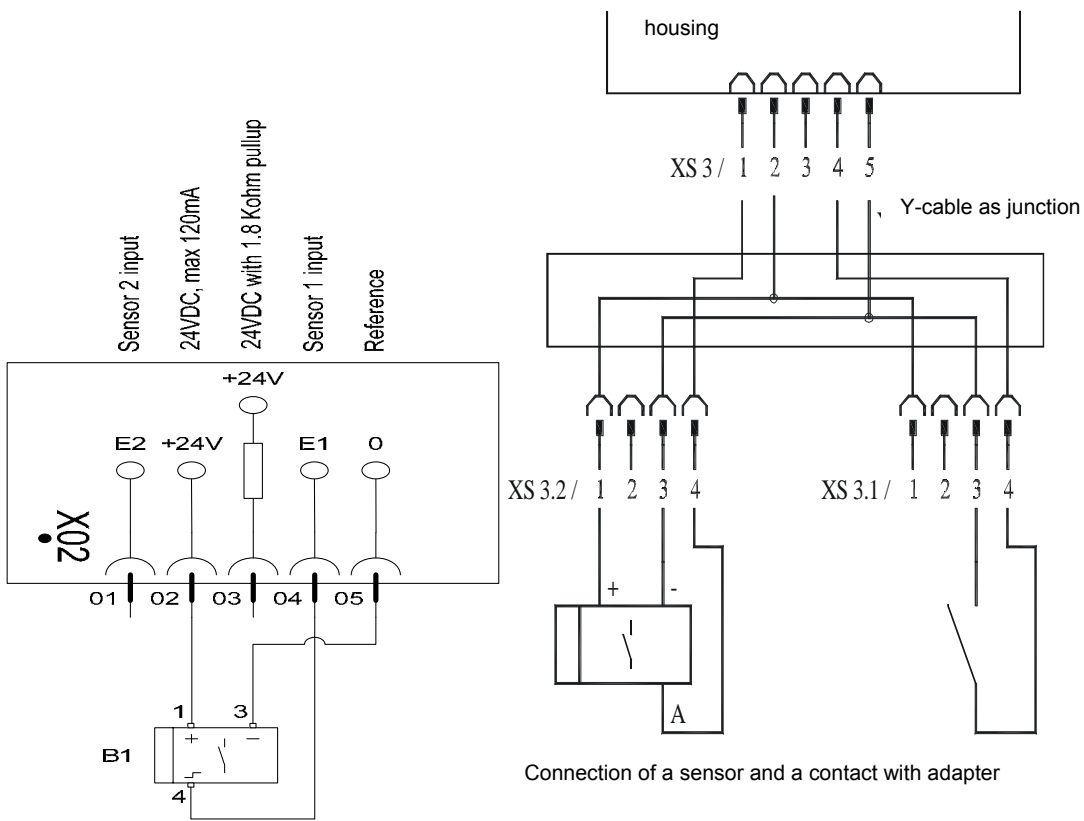
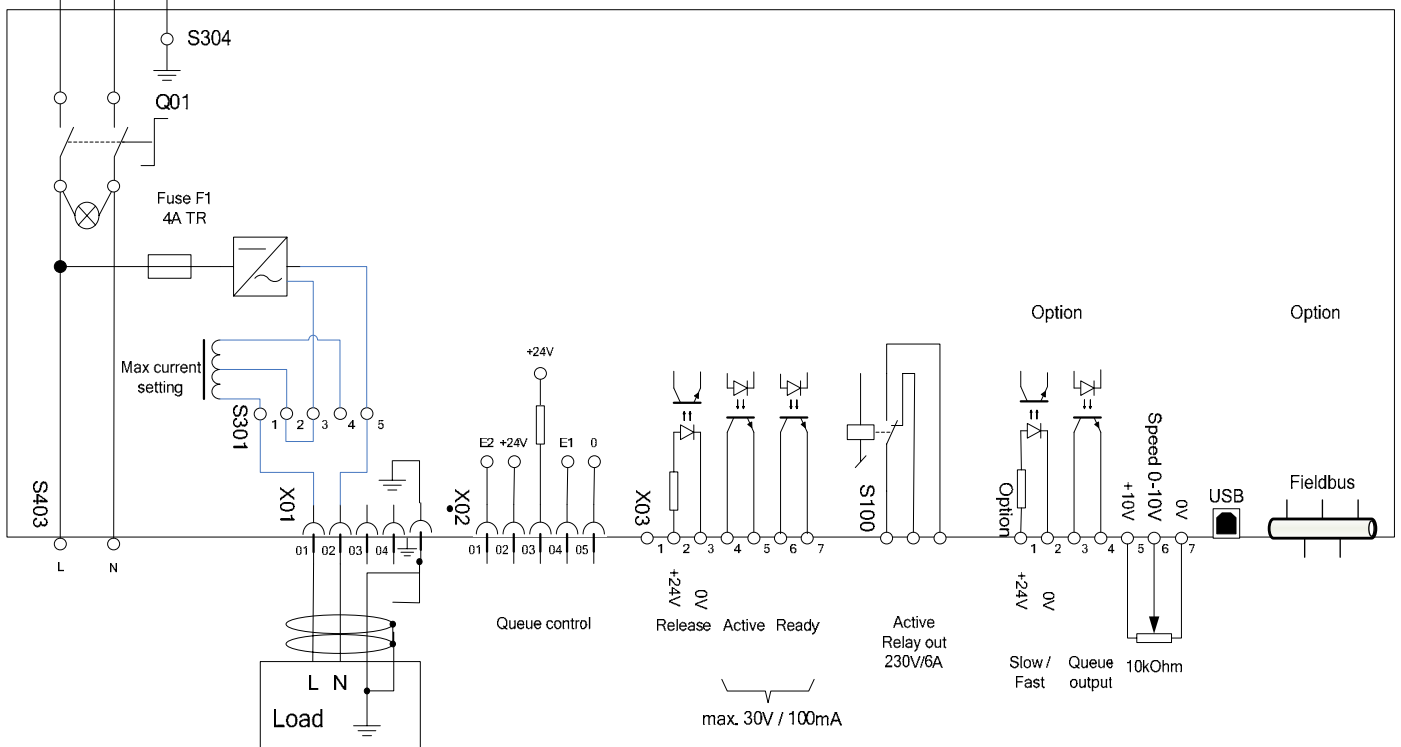

Fig 2 Proximity Switch / Active Optical Sensor

Connection diagram

ESR 2500 / ESR 2800



5 The Display of the Control Unit (keypad)

5.1 Control Panel – Display

The control panel of the ESR2500/2800 control unit consists of 4 keys and a display with 2x16 characters.

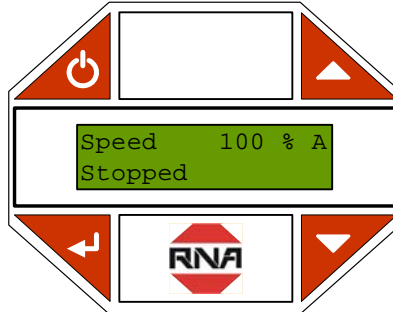

The keys have the following functions:

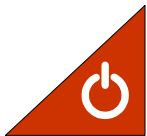

ON / OFF

During calibration, this key is also used as the Escape key to end calibration.

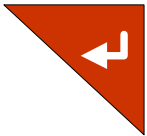

Enter:

This is used to activate menus or parameter settings as well as to finally acknowledge these settings.

When a parameter has been activated for setting, the parameter value is marked in brackets, as is shown here:

"< XXXX >"

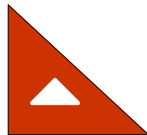

Arrow keys:

These keys are used to navigate through the menus.

If a parameter is activated, they are used to set this parameter.

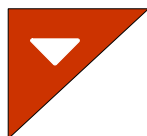

5.2 Navigating Through the Menus

Operation of the ESR2500/2800 control system is divided into 1 main and 2 submenus. From the main menu, one has access to the setting or calibration menu by entering the appropriate password for this menu.

The arrow keys are used to navigate up or down through the particular menus. The menus are circular, so that navigating past the last page of a menu will take you back to the first page again and vice-versa.

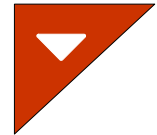
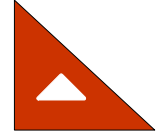

To change the parameter of a certain option, first navigate to the desired option, as described above. To activate the submenu of this option, press the Enter key.

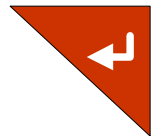

In the submenu, you can either adjust the parameter directly or reach a lower level of the submenu by applying the same procedure as described above. Once you have reached the parameter you would like to set or change, activate this parameter with the Enter key.

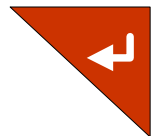

As soon as the parameter has been activated and can be reset, it will appear in brackets.

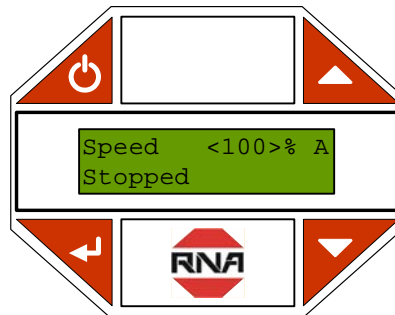

When navigating through the menus, the parameters are displayed without brackets.

When a parameter is active, the arrow keys change their function, i.e. they no longer serve to navigate through the menus but to set the active parameter.

Once you have finished with the parameter setting, press Enter to acknowledge the new setting and the parameter setting will be stored.

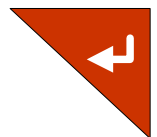

5.3 The Menu System

5.4 Main Menu

The Main menu consists of Status, Information and Performance settings.

The Status page displays the speed and the present status of the control system.

The speed can be set from 0-100% in the Manual operating mode as well as from minimum speed – which is calculated by the control system – to 100% in the Auto operating mode.

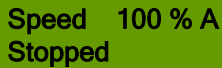

Speed 100 % A
Stopped

The speed setting determines the vibration amplitude.

The operating mode is displayed to the right of the speed percentage, i.e. with an M if the control system is in Manual operating mode and with an A if it is in Automatic operating mode.

In Manual operating mode, the speed is displayed in percent of the maximum output voltage. If the control system is calibrated and the operating mode is switched to Automatic, then the speed will be displayed as a percentage of the maximum calibrated vibration (speed).

The second line shows the present status of the control system.



Speed 100 % A
Stopped

Stopped: The feeder has been stopped with the ON / OFF key.

Ready: The feeder is stopped through an external source like e.g. an accumulation sensor, the external release input or a fieldbus command.

Operation: The feeder is in operation.

Fault: There is a fault.

After the Status text, the display shows the status of the external signals starting with “*” and followed by a “1” if Accumulation Sensor 1 is active, by a “2” if Accumulation Sensor 2 is active and by an “R” if Release Input has been set as active, i.e. the feeder is not released.



Speed 100 % A
Ready *12R >AN

OPTION

If the feeding speed is controlled by an external source, the active control type is displayed with an > followed by a two-character code.

The character codes are:

“HS” Speed is set to high speed.

“LS” Speed is set to low speed.

“AN” Speed is controlled by the analog input.

“FB” Fieldbus controls the control system.



Speed 100 % A
Ready >FB

The Info page shows the measured values for voltage, current, mains current and frequency.

The page “Current Settings” has to be configured according to the wired current setting in the Calibration menu!

The page “Extended” enables access by means of a password to settings and calibration. The preset password for the Settings menu is 1000 and for the Calibration menu 2000.

Settings menu

Some of the features in the “Settings Menu” are optional (in preparation) and have to be activated by entering an activation code. Accordingly, access to related submenus remains blocked until the corresponding activation code has been entered. If a menu is blocked, a little padlock will be shown in the bottom right-hand corner of the display.



Thus, the menu system only refers to the menu features that are activated. In addition, this makes navigating through the menus very simple, because there is only a minimum of menus one has to navigate through.

The activation codes are unique for every single control system and can be purchased by indicating the desired option together with the series number of the unit. With some of the options, additional cables or additional hardware will have to be installed in the unit.

After activating an optional feature by entering the corresponding activation code, the whole submenu tree opens up and you will have access to the parameter settings in connection with this feature.

As a special parameter via digital inputs or outputs, you can choose whether the function is to be configured as active high (24V) or active low (0V).

Multiple calibration: (OPTION in preparation)

The ESR2500 / 2800 controls are prepared for the “Multiple Calibration” option.

Once this option has been activated with the corresponding activation code, up to eight single calibrations and settings can be stored. This means that you can operate up to eight different vibratory bowl feeders, alternatively up to eight different settings, with just one control unit (alternating bowls).

All the feeder-related calibration values and setting parameters like sensor type and functionality, ramps, etc. are specifically filed for each of the sorting installations.

Only common parameters like display settings and selected language, etc. are generally valid for all calibrations.

In the detailed parameter description further below, the parameters are marked as “Setting-specific” or “General”.

Accumulation monitoring control:

The feeder can be controlled with up to two 24V signals at “Sensor connection” X3. Refer to connection diagram on page 13. The signal can, for instance, come from a photocell that monitors whether an output track is full or not. The submenus of the accumulation monitoring control supply possibilities to configure accumulation signals.

Each input can be set as “blocked”, “active at 24V” or “active at 0V”. If the input has been set to “blocked”, the control system ignores this signal. If the input has been set to “active at 24V” or “active at 0V”, an active accumulation signal forces the control system into “Ready Status” and stops the feeder. As soon as the signal becomes inactive, the control system switches over to “Active Status” and the feeder starts to run again.

A start and stop delay can be configured for every sensor input. Delay is the time in ms between receiving the sensor signal and processing it.

The sensor types NPN and PNP can be selected on the page Sensor Type.

On the Sensor Link page, you can combine two sensor inputs as “AND”, “OR” as well as “XOR”. If set to “AND”, both signals have to be active before the control system stops the feeder. If set to “OR”, only one of the two signals has to be active before the control system stops the feeder. If set to “XOR”, the control system stops the feeder if both input signals oppose each other.

Parameter description	Output parameter	Range	Comment
Sensor Input 1			
Stop / Start	inactive	active / 0V / 24V	Setting-specific
Start delay	300 ms	0 - 60000ms	Setting-specific
Stop delay	300 ms	0 - 60000ms	Setting-specific
Sensor type	NPN	NPN / PNP	Setting-specific
Sensor input 2			
Stop / Start	inactive	active / 0V / 24V	Setting-specific
Start delay	300 ms	0 - 60000ms	Setting-specific
Start delay	300 ms	0 - 60000ms	Setting-specific
Sensor type	NPN	NPN / PNP	Setting-specific
Sensor links	AND	AND / OR / XOR	Setting-specific

Ramps

Every time the control system sets the feeder going, the Start ramp (soft start) sets a time-controlled ramp for an oscillation amplitude. At this moment, the control system changes over to Operation status. If this time has been set too short, the vibratory bowl feeder strikes. Because of its own dynamic reaction, heavy feeders tend to overoscillate if the vibration is built up too quickly.

Stopping the vibratory bowl feeder should not normally be delayed. A delay could, however, be necessary in some cases to avoid the wrong orientation of parts on the feeder when it is stopped abruptly.

The time setting determines how long the oscillation build-up from 0% to 100% or its phasing out from 100% to 0% will take. For example: if the “Start Ramp” is set to 1000 ms, the feeder will take 1 second to build up the oscillation from 0% to 100%, and 500 ms to build up the oscillation from 0% to 50%.

Parameter description	Output parameter	Range	Comment
Start ramp	300 ms	50 - 20000ms	Setting-specific
Stop ramp	300 ms	50 - 20000ms	Setting-specific

Display setting

The display on the control system can be configured according to wish.

Contrast / brightness can be set in the menu under Display Calibration. If the light is set to "Normal", it will be switched on by pressing a key and it goes out again after 10 seconds. If the light is set to "On", it will stay on all the time, and if it is set to "Off", it will stay off all the time.

Also the language can be selected (see table).

Parameter description	Output parameter	Range	Comment
Contrast	50 %	0 - 100%	General
Brightness	100 %	0 - 100%	General
Light control	Normal	Normal / Automatic OFF / ON	General
Language	English	English / German / Danish / French	General

Communication

The submenu "Release" supplies alternatives to set the release input to "blocked", "active" at 24V or "active" at 0V. If the input has been set to "inactive", the control system ignores this signal. If the input has been set to "active" at 24V or 0V, an active release signal will release the control system and the feeder starts. As soon as the signal becomes "inactive", the control system switches over to "Ready Status" and the feeder stops. A switch-on and switch-off delay of the release signal can be configured separately.

The submenu "Active Output" is used to configure the Active output signal that can be set to "Active On" or "Active Off" when the feeder is in operation. The signal can also be delayed before it becomes inactive.

The submenu "Active Relay" supplies similar functions to the submenu "Active", with the exception that the output signal drives a relay.

The submenu "Ready Output" is used to configure the Ready output signal that can be set to "Active On" or "Active Off" when the feeder is ready for operation.

Parameter description	Output parameter	Range	Comment
Release Input 2			
Release On	Inactive / active	Blocked / 0V / 24V	Setting-specific
Release delay Start	300 ms	0 - 60000ms	Setting-specific
Release delay Stop	300 ms	0 - 60000ms	Setting-specific
Active Output			
Active output On	active / off		Setting-specific
Active output Off delay	300 ms	0 - 60000ms	Setting-specific
Active Relay Output			
In operation =	Inactive / active / off		Setting-specific
Active output relay Off delay	300 ms	0 - 60000ms	Setting-specific
Ready Output			
Ready =	Inactive / active / off		Setting-specific

Analog speed input (option in preparation)

The speed setting (0-100%) can be controlled from an analog input that can be set to 0-10V, 0-5V or 4-20mA.

Parameter description	Output parameter	Range	Comment
Set 100% speed	0-10V	0-10V/0-5V / 4-20mA	Setting-specific

High/low speed (option in preparation)

The high/low input signal can switch the control system back and forth between “high” and “low” speed. High speed corresponds to the speed setting, whereas a low speed corresponds to the percentage of the current speed setting.

The signal for high/low can be configured as follows: if the signal is set to Blocked, the control system will ignore this signal. If it is set to Active at 24V or 0V, an active signal adjusts the control system to a high speed and an inactive signal adjusts it to low speed. Low speed is set to a percentage of the current speed setting. An acceleration delay can be configured to accelerate a delay time received from an active input signal to the control system to high speed. A deceleration delay can also be set. This is the time between a received inactive signal and the moment in which the feeder starts to slow down to a low speed.

Parameter description	Output parameter	Range	Comment
High speed	Blocked	Blocked / 0V / 24V	Setting-specific
Low speed percent	25%	0-100%	Setting-specific
Acceleration delay	300 ms	0-60000ms	Setting-specific
Deceleration delay	300 ms	0-60000ms	Setting-specific

Multiple calibration (option in preparation)

The stored parameters for up to eight programmes are selected with this menu.

Parameter description	Output parameter	Range	Comment
Choose setting	Setting 1	1-8	General

Active brake (option in preparation)

The active brake immediately stops the feeder when a Stop command has been given, contrary to the resonance dying away on its own. This prevents the feeder from “coasting”.

This option is especially useful when applying counters, i.e. when an exact number of parts is to be counted without that surplus or undesired parts fall from the feeder after the correct number of pieces has been counted.

It is very important to set the brake time correctly.

The number of braking times can be configured. If the number of braking times is too low, the feeder will not fully stop and a small amount of oscillation remains after stopping. If the number of braking times is too high, the control system will then overbrake the feeder, which causes a new oscillation to start after stopping the feeder. In both cases, a little bit of “coasting” is to be expected.

If this option is activated, the calibrating procedure will adjust the number of braking times.

Parameter description	Output parameter	Range	Comment
Brake setting	10	0-50	Setting-specific

Fieldbus (option in preparation)

In this submenu, the fieldbus control can be activated and the fieldbus node number set. Please refer to the fieldbus document about controlling the device through a fieldbus.

Parameter description	Output parameter	Range	Type
Remote controls	Blocked	Blocked / released	General
Node no.	10	1-125	General

Changing the password

The password can be changed in the Settings menu (general). The standard password is 1000. If one has forgotten the active password, it can be reset to factory settings with a “Memory Reset”.

Warning: this sets all the parameters back to factory settings again!

Activation code

Before any of the option features can be used, it has to be released with an activation code. Please contact Customer Service to find out how the optional features can be released.

Calibration menu

Calibration procedure

To ensure that the control unit with its connected vibratory bowl feeder functions properly, it has to be calibrated so that it is perfectly adjusted to the corresponding feeder. After calibration, the corresponding calibration parameters are stored and loaded automatically every time the control unit is switched on.

Calibration is only necessary when:

- 1 The mechanical features of the feeder have been changed, i.e. changed number of springs, changed magnet gap or the OE was changed or replaced.
- 2 The electrical properties of the feeder are going to be changed, i.e. the magnets are going to be replaced or the air gap of the magnet is going to be changed.

The calibration procedure is fully automatic and requires no inputs through the operator.

To start the calibration procedure, first navigate to the Calibration menu and enter the correct calibration number.

Select
Cal No <1>

Then start with the calibration.

Run Calibration
Cal No 1

A Progress bar is displayed during the entire calibration procedure.

Calib. Progress

...

The calibration procedure ends without errors.

Calibration
succeeded

Should one or more errors occur during the calibration procedure, this/these error(s) will be shown on the display. Press Enter to accept an error and continue to the next error, if any.

Fine calibration

Parameter description	Output parameter	Range	Type
Maximum speed	NA	1000-100.000	Setting-specific
Minimum speed	NA	1000-30.000	Setting-specific
Cushioning	50%	1-100%	Setting-specific

Fine calibration maximum speed

The maximum speed at which the feeder is operated is set here. The feeder is switched on and the desired maximum speed set. If the feeder starts to strike at maximum speed, it must be switched off immediately by pressing the ON/OFF key. Reduce the set value by around 5-10% and then switch the feeder on again to make sure that no mechanical striking is caused any more. Press the "Enter" key whilst the feeder is running to store the new maximum speed, or press the "Enter" key whilst the feeder is stopped to return to the previous maximum speed.

Fine calibration minimum speed

The minimum speed with which to operate the feeder can be set here. The parts in the bowl feeder should move very slowly. Switch the feeder on and reduce the value. It is particularly important to make sure that the feeder is running steadily before leaving the menu. The reason for this is that the automatic calibration of the alarm threshold and operating conditions are stored when leaving this menu.

Caution! The control unit can only adjust the oscillation amplitude and frequency if there is a certain quantity of motion. If this quantity is too low, the control system cannot operate the feeder with resonance and the feeder stops vibrating. The set value then has to be raised so long until there is an acoustic or visible vibration of the feeder. The value can be reduced again afterwards, but one must make sure that the vibration does not stop completely.

If it is not possible to hear or see the vibration during this adjustment, a stability bar in the display shows how stable the feeder is running. If the feeder frequency moves away from the resonance, it is displayed in the stability bar. If the bar begins to flicker or shows a frequency error of more than two bar points, then the speed setting should be raised until the bar is stable again.

Once the settings are done, press the "Enter" key whilst the feeder is running to store the new minimum speed. Press the "Enter" key whilst the feeder is stopped to return to and keep the previous minimum speed.

Damping setting

Damping for regulation of the oscillation amplitude can be set here. If the feeder shows to over-oscillate when starting or if changes in the speed setting cause a fluctuation in the oscillation amplitude, it is recommendable to slightly raise the value. If none of the above cases occur with the feeder, but if it reacts slowly to load changes, it is recommendable to set the value slightly lower.

Current setting

The control must recognise the connected feeder, i.e. it has to be informed about the feeder's maximum current consumption. Refer to Installation on page 12.

Caution! This value is used to adjust the control unit to the connected vibratory bowl feeder.

Operating Mode

The Operating Mode can be switched back and forth between Auto and Manual. The Auto operating mode can only be selected if the control system has been calibrated. If the operating mode has been set to Manual, the control system uses the manual frequency as a fixed output frequency. In Manual operating mode, the automatic oscillation amplitude control also gets lost. Manual frequency can be set in the submenu under "Manual Frequency".

Changing the password

The password for the calibration menu can be changed here. The standard password is 2000. If one has forgotten the active password, it can be reset to factory settings with a "Memory Reset".

Warning: this sets all the parameters back to factory settings again!

Resetting to factory setting

To reset to factory setting, switch off the supply voltage, press and firmly hold the two arrow keys “up” and “down” and then switch the supply voltage on again. The display will show the following:

Memory
reset

6 Technical Data

Technical Data

	ESR2500/110V	ESR2500/230V	ESR2800
Supply voltage	115Volt AC, 50/60Hz, +/-10%	230Volt AC, 50/60Hz, +/-10%	
Output voltage	0-104Veff	0-208Veff	
Max. operative current	5,5Aeff / 2,75Aeff / 1,83Aeff / 1,37Aeff changeable	9Aeff / 4,5Aeff / 3Aeff / 2,25Aeff changeable	
Min. operative current	2% of the max. operative current		
Output frequency	25-150Hz mechanical frequency		
Internal fuse	F401 = 4A		
Soft start time, soft stop time	0.05 to 20 seconds		
External target value	0-10Vdc / 0-5Vdc / 4-20mA / fieldbus control / soft key-adjustable		
Sensor inputs	2 soft keys, changeable for NPN or PNP sensor		
Remote control inputs ON/OFF	24Vdc soft key-changeable polarity		
Remote control inputs SLOW/FAST	24Vdc soft key-changeable polarity		
Power supply sensor	24Vdc, max. 25mA in total		
Sensor delay ON	0....60 secs.		
Sensor delay OFF	0....60 secs.		
Outputs	24Vdc / 20mA optocoupler outputs		
Active output	Relay voltage-free changeover contact max. 250V / 8A		
Fieldbus	Variable fieldbus module		
USB standard	1.1 (full speed)		
USB plug	USB type B “unit plug”		
Operating temperature	0.... 0.... 40°C		
Protection	IP54		

Accessories

Plate		
XS2	Communication connection cable	
FB1	DPV1	OPTION

7. Alarms

Different alarm signals and other messages can appear on the display under certain circumstances. The alarm signals have a priority order. If more than one alarm is active, only the one with the highest priority will appear. The operator has to acknowledge the alarm by pressing the Enter key to reset it. Alarms also produce an alarm output signal. This makes it possible to show the alarm with an indicator light or some other alarm device.

Priority (alarm no.)	Alarm text
1	Short circuit protection active
2	Overload protection active
3	Load switched off
4	Frequency error
5	Vibration reduced
6	Resonant frequency not found
7	Resonant maximum not found
8	Offset error PWM reading
9	Offset error Voltage reading
10	Offset error Current reading
11	Offset error Rejection common operating mode "Distance measurement mode"
12	Magnet core saturation not found
13	Fieldbus error

Alarm Signals and Troubleshooting

Short circuit protection active

The short circuit protection becomes active when the current reaches a peak value of more than 20 amperes. In this case, the control system immediately switches off the output voltage to protect its output level against damage. The alarm signal remains on the display until it is acknowledged by pressing the Enter key. The alarm appears when there is a pure short circuit at the control output or when the connected feeder is much larger than the max. control current.

Remedy:

1. Switch the feeder off and check the cables and vibratory bowl feeder for defects.
2. Make sure that the current setting value is set to the right value, as indicated (look into the table 2 And 3 page 11 + 12)

Overload protection active

The overload protection becomes active when the current exceeds the value of the maximum RMS current by twice as much. In this case, the control system immediately switches off the output voltage to protect its output level against overloading. The alarm signal remains on the display until it is acknowledged by pressing the Enter key. This alarm appears when there is an overload condition because the connected feeder is much larger than the current limit setting permits, or when there is a pure short circuit at the control output.

Remedy:

1. Switch the feeder off and check the cables and vibratory bowl feeder for defects.
2. Make sure that the current setting value is set to the right value, as indicated (look into the table 2 and 3 page 11 + 12)

Load switched off

This signal appears when the feeder has been switched off by the control system, or in the case of a cable breakage, or when the connected feeder is very small in relation to the current limit setting.

Remedy:

1. Switch off the connected feeder and check the cables and vibratory bowl feeder for defects.
2. Check the feeder connection for bad connections or failures.
2. Make sure that the current setting is set correctly. Refer to Table on page 12.

Frequency error

The resonant frequency of the feeder has now reached an external frequency limit. This can have different reasons:

- 1 Inadequate setting of the minimum speed. Whilst setting the minimum speed, the control system finds the external limits of the permissible frequency range. This is why it is important that the feeder runs steadily and has done so for at least 10 seconds before leaving this calibration menu. The limits are stored when leaving the menu. The control unit can only automatically control the oscillation amplitude and frequency if there is a certain quantity of motion. If the feeder runs so slowly during calibration of the minimum speed that the frequency becomes unstable, the found frequency limits could be incorrect.

Remedy:

Reset the minimum speed and make sure that the feeder runs steadily before leaving this menu.

- 2 Very high load with heavy piece parts. Accordingly, the frequency has dropped by more than 20% owing to the heavy load. In this case, the alarm can appear when the total weight of the feeding system is increased by over 20%.

Remedy:

None. In this case, the alarm can be ignored. The feeder will continue to run, but the feeding speed will probably be reduced if the load continues to increase and the maximum current setting of the control system is reached.

- 3 A broken or loose spring.

Remedy:

Check the springs; if necessary, replace the spring bolts and tighten again.

Vibration reduced

This alarm appears when the control system cannot maintain the desired speed (oscillation amplitude) without overloading the oscillation magnets.

This alarm signal appears when the feeding speed is less than half the set speed, but the feeder receives full current. This is not necessarily an error; the cause can be due to overloading the feeder with heavy parts. Another possible reason why the feeder cannot oscillate freely is a broken or loose spring. The air gap of the magnet could be blocked with dirt.

Other mechanical blockings of the feeder oscillation.

This alarm signal can also appear if a heavily loaded feeder is started very quickly. It takes some time then until the feeder reaches the desired speed, although it gets full current.

Remedy:

- 1 Reduce the load of the feeder.
- 2 Set the soft start time and perhaps damping to a higher parameter value. This has no detrimental effect on putting into operation, as the load is the limiting factor of the starting speed.
- 3 Check whether the feeder can oscillate freely.
- 4 Check the springs. If necessary, replace the springs and tighten again; also clean the air gap of the magnets.
- 5 Check whether there are any other mechanical blockages on the feeder and eliminate them.

Resonant frequency not found

This error stands in connection with the calibration procedure and appears when the control system cannot find the resonant frequency of the feeder.

Remedy:

- 1 Check whether the feeder can oscillate freely and that no pieces are lying on top of it.
- 2 Check the springs. If necessary, replace the springs and tighten again; also clean the air gap of the magnets and reset.
- 3 Check the current setting of the control system and set correctly in accordance with the feeder.

After having checked everything as described above, try to recalibrate the feeder.

Resonant maximum not found

This error stands in connection with the adjusting procedure and appears when the control system cannot adjust the frequency properly in relation to the feeder.

Remedy:

- 1 Check whether the feeder can oscillate freely and that no pieces are lying on top of it.
- 2 Check the springs. If necessary, replace the springs and tighten again; also clean the air gap of the magnets.
- 3 Check the current setting of the control system and set correctly in accordance with the feeder.

After having checked everything as described above, try to readjust the feeder.

Offset error PWM reading

This is a self-diagnosis error and only happens in connection with the calibration procedure, i.e. when there are such grave errors in the modulation circuit that they could not be offset by the automatic offset setting.

Remedy:

- 1 Try to recalibrate.
- 2 Please contact Customer Service.

Offset error Voltage reading

This is a self-diagnosis error and only happens in connection with the calibration procedure, i.e. when there are such grave errors in the low-potential circuits that they could not be offset by the automatic offset setting.

Remedy:

1. Do another calibration.
2. Please contact Customer Service.

Offset error Current reading

This is a self-diagnosis error and only happens in connection with the calibration procedure, i.e. when there are such grave errors in the low-potential circuits that they could not be offset by the automatic offset setting.

Remedy:

- 1 Try to recalibrate.
- 2 Please contact Customer Service.

Offset error Rejection common operating mode “Distance measurement mode”

This is a self-diagnosis error and only happens in connection with the calibration procedure, i.e. when there are such grave errors in the low-potential circuits that they could not be offset by the automatic offset setting.

Remedy:

- 1 Try to recalibrate.
- 2 Please contact Customer Service.

Magnet core saturation not found

This is a self-diagnosis error that only happens in connection with the calibration procedure. This error appears when the control system cannot offset the magnet core saturation in relation to the feeder.

Remedy:

- 1 Try to recalibrate.
- 2 Make sure that the magnet air gaps are adjusted correctly and not blocked with metal dust.
- 3 Make sure that the magnet is tight and cannot move mechanically.

Fieldbus error

This alarm appears when connection to the master gets lost.

Remedy:

- 1 Make sure that the master is switched on.
- 2 Check the cables.

General errors

- 1 The control system does not start.

Remedy:

- 1.1 Check whether the current is connected and the mains switch is switched on. The mains switch lights up green when the current is connected correctly.
- 2 The current is switched on, but the unit still does not start.
- 3 The internal fuse F401 has been triggered. Replace the fuse by a 5x20mm 4A time-lag fuse.



Qualified staff required. (look into the table 2 and 3 page 11 + 12)



Dangerous voltage.

The DC connection capacitors of the vibratory control remain charged after the current has been switched off. After switching off the control system, wait as long as indicated below.

ESR 2500	10 minutes
ESR 2800	15 minutes

- 4 The unit starts and the display shows “Ready”, but the feeder does not run.

Remedy:

- 4.1 Make sure that the control system has been released, i.e. from all external inputs. Refer to Section 5.3 for details.
- 4.2 Make sure that the digital inputs not used have not been set to Active in the Settings menu.
- 4.3 Please contact Customer Service.



Rhein-Nadel Automation GmbH

Reichsweg 19/42 • D - 52068 Aachen
Tel (+49) 0241/5109-159 • Fax (+49) 0241/5109-219
Internet www.rna.de • Email vertrieb@rna.de

Rhein-Nadel Automation GmbH

Zweigbetrieb Lüdenscheid
Nottebohmstrasse 57 • D - 58511 Lüdenscheid
Tel (+49) 02351/41744 • Fax (+49) 02351/45582
Email werk.luedenscheid@rna.de

Rhein-Nadel Automation GmbH

Zweigbetrieb Ergolding
Ahornstrasse 122 • D - 84030 Ergolding
Tel (+49) 0871/72812 • Fax (+49) 0871/77131
Email werk.ergolding@rna.de



HSH Handling Systems AG

Wangenstr. 96 • CH - 3360 Herzogenbuchsee
Tel (+41) 062/95610-00 • Fax (+41) 062/95610-10
Internet www.rna.de • Email info@handling-systems.ch



RNA AUTOMATION LTD

Hayward Industrial Park
Tameside Drive, Castle Bromwich
GB - Birmingham, B 35 7 AG
Tel (+44) 0121/749-2566 • Fax (+44) 0121/749-6217
Internet www.rna-uk.com • Email rna@rna-uk.com



Vibrant S.A.

Pol. Ind. Famades C/Energia Parc 27
E - 08940 Cornellà Llobregat (Barcelona)
Tel (+34) 093/377-7300 • Fax (+34) 093/377-6752
Internet www.vibrant-rna.com • Email info@vibrant-rna.com