



Standard Product Information

Hoppers BVL



Abb: BVL 5 VA

- Stainless steel hopper, easily integrated with RNA standard equipment and control boxes
- Available in a range of sizes
- Suitable for lightweight parts and pharmaceutical applications
- Off the shelf spares readily available for this cost-effective hopper



Technical Data:



Abb: BVL5 to BVL 50

	BVL 5	BVL 25	BVL 50
Volume	7 l	25 l	50 l
Weight	15 kp	25 kp	50 kp
Drive Unit	SLL 400-400	SLL 400-800	SLL 804-800
Dimensions (mm)			
A	515	885	1.015
B	150	150	200
C	170	220	280
D	190	250	320
E	165	163	228
F	275	313	428
I	200	450	300
J	170	220	230
L	90	90	180



Standard:	<ul style="list-style-type: none"> Hopper in stainless steel VA Voltage 200 V / 50 Hz
Optional Extras:	<ul style="list-style-type: none"> Hopper covered with polyurethane Voltage (110V/ 50-60 Hz; 220V/ 50-60Hz)
Accessories:	<ul style="list-style-type: none"> Control units Level controller stands

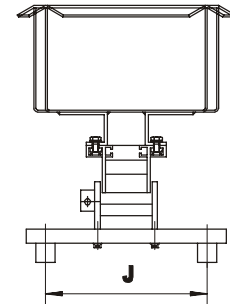
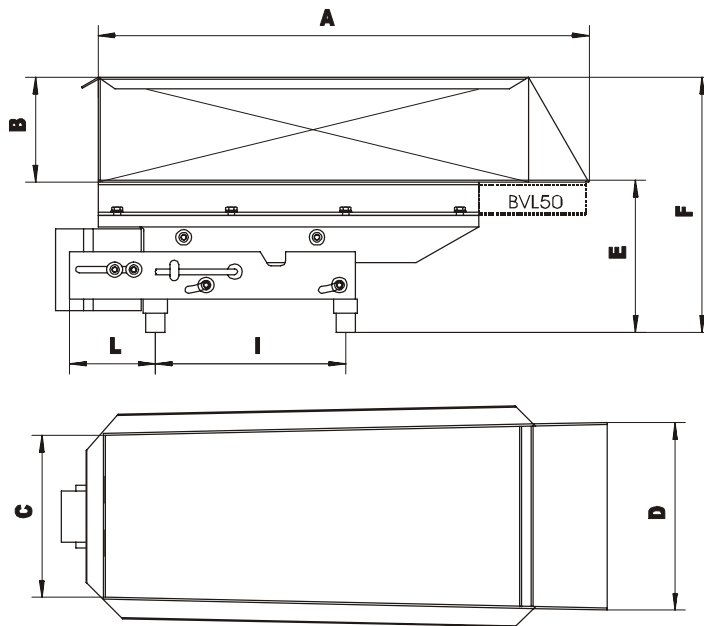
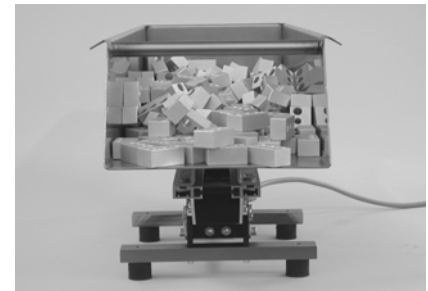

RNA Automation Limited
 Hayward Industrial Park, Tameside Drive, Castle Bromwich, Birmingham B35 7AG
 Telephone +44 (0) 121 749 2566 Fax +44 (0) 121 749 6217
www.rna-uk.com e-mail aperks@rna-uk.com