



## Product information

## Hoppers BV



Abb.: BV 30 V2A

The hopper BV 8 – BV 200 are based at the renown series linear feeder type SLL and SLF.

They are suited for the storage for small and middle workpieces (BV8– BV60) and will be established for the filling of bowls, f.e. inside a feeding system. The hoppers has the advantage of a closed tray, so that no thin-walled work pieces or shavings can enter into the groove. The types BV100-BV200 can not only be used for high feeding rates and high filling volume but also for feedings from bigger and/or heavier work pieces.

With an adjustment with increasing speed to the outlet there is an advantage of a pre-separation of the workpieces, this means, that there is the possibility of a specified filling of downstream equipment.



## Technical data:



Abb.: BV 8 to BV 60



Abb.: BV 100 to BV 200

	<b>BV 8</b>	<b>BV 15</b>	<b>BV 30</b>	<b>BV 60</b>	<b>BV 100</b>	<b>BV 150</b>	<b>BV 200</b>
<b>Fillvolume</b>	<b>8 l</b>	<b>15 l</b>	<b>30 l</b>	<b>60 l</b>	<b>100 l</b>	<b>150 l</b>	<b>200 l</b>
<b>Fillweight</b>	<b>30 kg</b>	<b>30 kg</b>	<b>35 kg</b>	<b>100 kg*</b>	<b>150 kg*</b>	<b>200 kg*</b>	<b>200 kg*</b>
<b>Drive unit</b>	SLL 400-400	SLL 400-400	SLL 400-800	SLL 804-800	SLF 1000	SLF 1000	SLF 1000
<b>Dimensions (mm)</b>							
<b>A</b>	<b>700</b>	<b>700</b>	<b>1.100</b>	<b>1.250</b>	<b>1550</b>	<b>1550</b>	<b>1550</b>
<b>B</b>	<b>130</b>	<b>170</b>	<b>190</b>	<b>250</b>	<b>200</b>	<b>250</b>	<b>300</b>
<b>C</b>	<b>210</b>	<b>260</b>	<b>220</b>	<b>280</b>	<b>500</b>	<b>500</b>	<b>500</b>
<b>D</b>	<b>266</b>	<b>316</b>	<b>314</b>	<b>389</b>	<b>680</b>	<b>680</b>	<b>680</b>
<b>E</b>	<b>53</b>	<b>53</b>	<b>58</b>	<b>123</b>	<b>124</b>	<b>124</b>	<b>124</b>
<b>F</b>	<b>283</b>	<b>323</b>	<b>348</b>	<b>473</b>	<b>505</b>	<b>555</b>	<b>605</b>
<b>H</b>	<b>122</b>	<b>143</b>	<b>145</b>	<b>173</b>	<b>250</b>	<b>250</b>	<b>400</b>
<b>I</b>	<b>200</b>	<b>200</b>	<b>450</b>	<b>300</b>	<b>370</b>	<b>370</b>	<b>370</b>
<b>J</b>	<b>170</b>	<b>220</b>	<b>220</b>	<b>230</b>	<b>400</b>	<b>400</b>	<b>400</b>
<b>L</b>	<b>90</b>	<b>90</b>	<b>90</b>	<b>180</b>	<b>260</b>	<b>260</b>	<b>260</b>

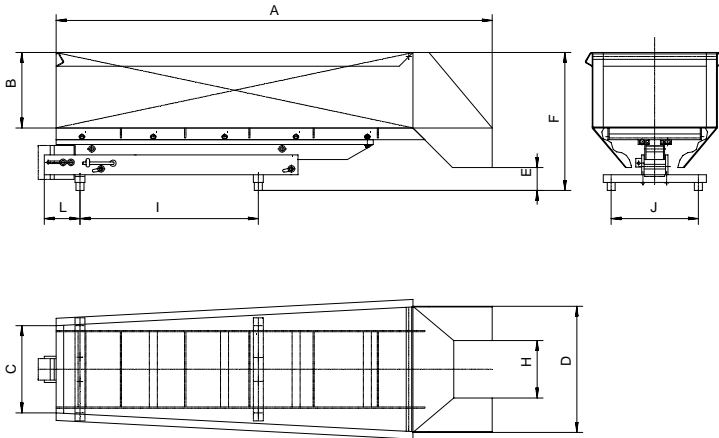
\* The maximum fillweight depends on the character of the work pieces.

### Achievements

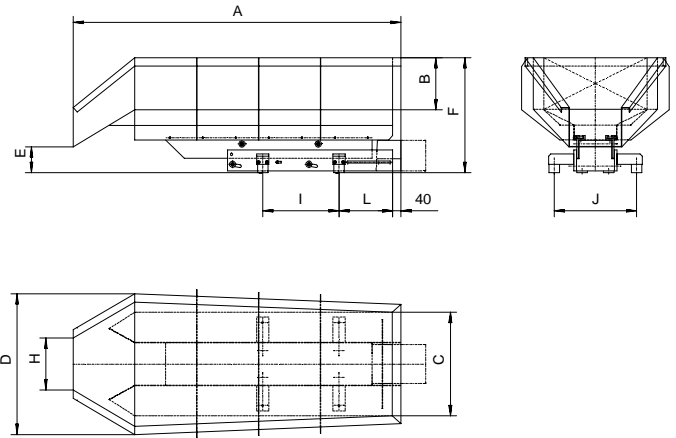
<b>Standard:</b>	<ul style="list-style-type: none"> <li>- Hopper in steel ST37-K and coated in PX</li> <li>- Nominal voltage 200 V / 50 Hz</li> <li>- Colour RAL 6011 reseda-green</li> </ul>
<b>Special design:</b>	<ul style="list-style-type: none"> <li>- Hopper coated with poly</li> <li>- Hopper in stainless steel V2A (1.4301)</li> <li>- Voltages (110V/ 50-60 Hz; 220V/ 50-60Hz)</li> </ul>
<b>Accessories:</b>	<ul style="list-style-type: none"> <li>- Control units</li> <li>- Level controller</li> <li>- Stands</li> </ul>

Technical changes reserved.



### RNA Automation Ltd

Hayward Industrial Park, Tameside Drive, Castle Bromwich, Birmingham B35 7AG

Tel: +44 (0) 121 749 2566 Fax: +44 (0) 121 749 6217

Email: sales@rna-uk.com Web: www.rna-uk.com